



**US Army Corps  
of Engineers**

Hydrologic Engineering Center

---

# **A Comparison of the One-Dimensional Bridge Hydraulic Routines from: HEC-RAS, HEC-2 and WSPRO**

**September 1995**

<b>REPORT DOCUMENTATION PAGE</b>			<i>Form Approved OMB No. 0704-0188</i>	
Public reporting burden for this collection of information is estimated to average 1 hour per response, including the time for reviewing instructions, searching existing data sources, gathering and maintaining the data needed, and completing and reviewing the collection of information. Send comments regarding this burden estimate or any other aspect of this collection of information, including suggestions for reducing this burden, to Washington Headquarters Services, Directorate for Information Operations and Reports, 1215 Jefferson Davis Highway, Suite 1204, Arlington, VA 22202-4302, and to the Office of Management and Budget, Paperwork Reduction Project (0704-0188), Washington, DC 20503.				
<b>1. AGENCY USE ONLY</b> <i>(Leave blank)</i>		<b>2. REPORT DATE</b> September 1995		<b>3. REPORT TYPE AND DATES COVERED</b> Research Document No. 41
<b>4. TITLE AND SUBTITLE</b> A Comparison of the One-Dimensional Bridge Hydraulic Routines from: HEC-RAS, HEC-2 and WSPRO			<b>5. FUNDING NUMBERS</b>	
<b>6. AUTHOR(S)</b> Gary W. Brunner, John H. Hunt				
<b>7. PERFORMING ORGANIZATION NAME(S) AND ADDRESS(ES)</b> US Army Corps of Engineers Institute for Water Resources Hydrologic Engineering Center 609 Second Street Davis, CA 95616-4687			<b>8. PERFORMING ORGANIZATION REPORT NUMBER</b> RD-41	
<b>9. SPONSORING / MONITORING AGENCY NAME(S) AND ADDRESS(ES)</b> N/A			<b>10. SPONSORING / MONITORING AGENCY REPORT NUMBER</b> N/A	
<b>11. SUPPLEMENTARY NOTES</b>				
<b>12a. DISTRIBUTION / AVAILABILITY STATEMENT</b> Approved for Public Release. Distribution of this document is unlimited.			<b>12b. DISTRIBUTION CODE</b>	
<b>13. ABSTRACT</b> <i>(Maximum 200 words)</i> The hydraulics of flow through bridges is an important aspect of computing water surface profiles. The computation of accurate water surface profiles through bridges is necessary in flood damage reduction studies, channel design and analysis, and stream stability and scour evaluations. There are several one-dimensional water surface profile computer programs available for performing these types of computations. The most widely used of these programs are HEC-2 (HEC, 1991) and WSPRO (FHWA, 1990). The Hydrologic Engineering Center (HEC) has recently released a new program for computing one-dimensional water surface profiles, called HEC-RAS (HEC, 1995). The purpose of this study was to evaluate the effectiveness of the new bridge hydraulics routines in HEC-RAS at sites with extensive observed data, and to compare HEC-RAS to HEC-2 and WSPRO, with respect to bridge modeling performance.				
<b>14. SUBJECT TERMS</b> Computer program, hydraulics, channels, water surface profiles, bridges, flood events, calibrations, observed data, model comparisons.			<b>15. NUMBER OF PAGES</b> 82	
			<b>16. PRICE CODE</b>	
<b>17. SECURITY CLASSIFICATION OF REPORT</b> UNCLASSIFIED	<b>18. SECURITY CLASSIFICATION OF THIS PAGE</b> UNCLASSIFIED	<b>19. SECURITY CLASSIFICATION OF ABSTRACT</b> UNCLASSIFIED	<b>20. LIMITATION OF ABSTRACT</b> UNLIMITED	

# **A Comparison of the One-Dimensional Bridge Hydraulic Routines from: HEC-RAS, HEC-2 and WSPRO**

**September 1995**

US Army Corps of Engineers  
Institute for Water Resources  
Hydrologic Engineering Center  
609 Second Street  
Davis, CA 95616

(530) 756-1104  
(530) 756-8250 FAX  
[www.hec.usace.army.mil](http://www.hec.usace.army.mil)

RD-41



# TABLE OF CONTENTS

<b>Acknowledgements</b> .....	iii
<b>Introduction</b> .....	1
<b>Overview of Bridge Hydraulics</b> .....	1
HEC-RAS .....	1
Cross Section Locations.....	2
Hydraulic Computations Through the Bridge.....	3
Low Flow Computations .....	3
High Flow Computations .....	7
Combination Flow .....	12
HEC-2 .....	13
Normal Bridge Method .....	13
Special Bridge Method .....	13
WSPRO.....	16
<b>Model Development</b> .....	19
Cross Section Data and Locations .....	19
Manning's n Values.....	20
Channel Bank Stations and Reach Lengths .....	20
Cross Section Effective Flow Area.....	21
Bridge Crossing Geometry .....	21
<b>Model Calibration</b> .....	21
Manning's n Values.....	21
Contraction and Expansion Coefficients .....	22
Final Model Adjustments.....	22
<b>Modeling Results</b> .....	22
<b>Summary and Conclusions</b> .....	23
<b>Appendix A</b> .....	A-1
<b>Appendix B</b> .....	B-1



## **Acknowledgements**

This Research Document was written by Gary W. Brunner and John H. Hunt. The development of the HEC-RAS, HEC-2, and WSPRO models, for each of the study sites, was performed by John H. Hunt under the direction of Gary W. Brunner. Technical guidance was also provided by Mr. Vern Bonner. Mr. Darryl Davis was the director of the Hydrologic Engineering Center during the course of this study.





# **A Comparison of the One-Dimensional Bridge Hydraulic Routines From: HEC-RAS, HEC-2, and WSPRO**

## **Introduction**

The hydraulics of flow through bridges is an important aspect of computing water surface profiles. The computation of accurate water surface profiles through bridges is necessary in flood damage studies, channel design and analysis, and stream stability and scour evaluations. There are several one-dimensional water surface profile computer programs available for performing this type of computation. The most widely used of these types of programs are: HEC-2 (HEC, 1991) and WSPRO (FHWA, 1990). The Hydrologic Engineering Center (HEC) has recently released a new program for computing one-dimensional water surface profiles, called HEC-RAS (HEC, 1995). The purpose of this study was to evaluate the effectiveness of the new bridge hydraulics routines in HEC-RAS at sites with extensive observed data, and to compare HEC-RAS to HEC-2 and WSPRO, with respect to bridge modeling performance.

Detailed data for 22 bridge sites were obtained from the US Geological Survey (USGS, 1978). The USGS collected extensive data for bridge crossings over wide, densely vegetated flood plains between 1969 and 1974. The data has been published in the form of Hydrologic Investigation Atlases, which are available to the public. Of the 22 sites, 13 were used for this study. Several of the sites had to be omitted because of sparse water surface measurements in the vicinity of the bridge. A few other sites were omitted due to inadequate bridge geometry and layout information. Of the 13 remaining data sets, 17 events were analyzed; that is, 8 sites had 1 flood each; and 4 sites had 2 floods each. Almost all of the events were class A low flow (open channel, subcritical flow through the bridge opening), while three of the events had water surfaces higher than the bridge low cord on the upstream side of the bridge.

## **Overview of Bridge Hydraulics**

In general, all three of the models compute water surface profiles by solving the energy equation, utilizing the standard step procedure. However, one of the main differences between these models is how they compute the water surface profile through a bridge. A description of the bridge hydraulics for each of the three models follows:

### **HEC-RAS**

The HEC-RAS bridge routines utilize four user-defined cross sections in the computations of energy losses due to the structure. A plan view of the basic cross section layout is shown in Figure 1.

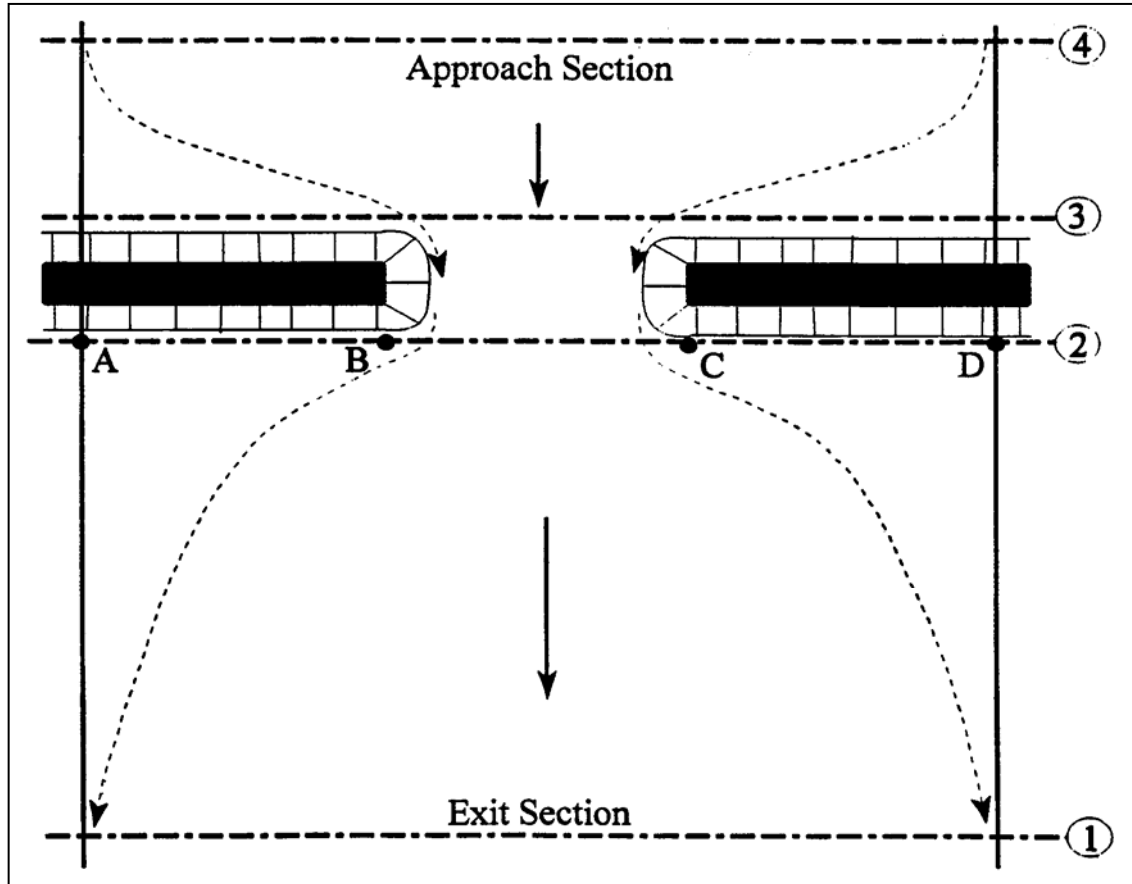

Figure 1. HEC-RAS Cross Section Locations at a Bridge

### Cross Section Locations

**Cross section 1** is located sufficiently downstream from the structure so that the flow is not affected by the structure (i.e., the flow has fully expanded). This distance should generally be determined by field investigation during high flows. If field investigation is not possible, then there are two sets of criteria for locating the downstream section. The USGS has established a criterion for locating cross section 1 a distance downstream from the bridge equal to one times the bridge opening width (the distance between points B and C on Figure 1). Traditionally, the Corps of Engineers criterion has been to locate the downstream cross section about four times the average length of the side constriction caused by the structure abutments (the average of the distance from A to B and C to D in Figure 1). The expansion distance will vary depending upon the degree of constriction, the shape of the constriction, the magnitude of the flow, and the velocity of the flow. Both criteria should be used as rough guidance for placing cross section 1. The user should not allow the distance between cross section 1 and 2 to become so great that friction losses will not be adequately modeled. If the modeler thinks that the expansion reach will require a long distance, then intermediate cross sections should be placed within the expansion reach in order to adequately model friction losses. The ineffective flow option can be used to limit the effective flow area of the intermediate cross sections in the expansion reach.

**Cross section 2** is located immediately downstream from the bridge (i.e., within a few feet). This cross section should represent the effective flow area just outside the bridge.

**Cross section 3** should be located just upstream from the bridge. The distance between cross section 3 and the bridge should be relatively short. This distance should only reflect the length required for the abrupt acceleration and contraction of the flow that occurs in the immediate area of the opening. Cross section 3 represents the effective flow area just upstream of the bridge. Both cross sections 2 and 3 will have ineffective flow areas to either side of the bridge opening during low flow and pressure flow profiles. In order to model only the effective flow areas at these two sections, the modeler should use the ineffective flow area option at both of these cross sections.

**Cross section 4** is an upstream cross section where the flow lines are approximately parallel and the cross section is fully effective. Because flow contractions can occur over a shorter distance than flow expansions, the distance between cross section 3 and 4 should be roughly one times the average width of the opening. However, these criteria for locating the upstream cross section may result in too short a reach length for situations where the width of the bridge opening is very small in comparison to the floodplain. An alternative criterion would be to locate the cross section a distance upstream equal to the average contraction width (the average of the distance from A to B and C to D in Figure 1).

During the hydraulic computations, the program automatically formulates two additional cross sections inside of the bridge structure. The geometry inside of the bridge is a combination of the bounding cross sections (sections 2 and 3) and the bridge geometry. The bridge geometry consists of the bridge deck and roadway, sloping abutments if necessary, and any piers that may exist. The user can specify different bridge geometry for the upstream and downstream sides of the structure, if necessary. Cross section 2 and the structure information on the downstream side of the bridge are used as the geometry just inside the structure at the downstream end. Cross section 3 and the upstream structure information are used as the bridge geometry just inside the structure at the upstream end.

### **Hydraulic Computations Through the Bridge**

The bridge routines in HEC-RAS allow the modeler to analyze a bridge with several different methods without changing the bridge geometry. The bridge routines have the ability to model low flow (Class A, B, and C), low flow and weir flow (with adjustments for submergence on the weir), pressure flow (orifice and sluice gate equations), pressure and weir flow, and highly submerged flows (the program will automatically switch to the energy equation when the flow over the road is highly submerged).

#### *Low Flow Computations*

Low flow exists when the flow going through the bridge opening is open channel flow (water surface below the highest point on the low chord of the bridge opening). For low flow computations, the program first uses the momentum equation to identify the class of flow. This is accomplished by first calculating the momentum at critical depth inside the bridge at the upstream and downstream ends. The end with the higher momentum (therefore most constricted section) will be the controlling section in the bridge. If the two sections are identical, the program selects the upstream bridge section as the controlling section. The momentum at critical

depth in the controlling section is then compared to the momentum of the flow downstream of the bridge when performing a subcritical profile (upstream of the bridge for a supercritical profile). If the momentum downstream is greater than the critical depth momentum inside the bridge, the class of flow is considered to be completely subcritical (i.e., class A low flow). If the momentum downstream is less than the momentum at critical depth, in the controlling bridge section, then it is assumed that the constriction will cause the flow to pass through critical depth and a hydraulic jump will occur at some distance downstream (i.e., class B low flow). If the profile is completely supercritical through the bridge, then this is considered class C low flow.

**Class A low flow.** Class A low flow exists when the water surface through the bridge is completely subcritical (i.e., above critical depth). Energy losses through the expansion (sections 2 to 1) are calculated as friction losses and expansion losses. Friction losses are based on a weighted friction slope times a weighted reach length between sections 1 and 2. The average friction slope is based on one of the four available alternatives in the HEC-RAS, with the average-conveyance method being the default. This option is user selectable. The average length used in the calculation is based on a discharge-weighted reach length. Energy losses through the contraction (sections 3 to 4) are calculated as friction losses and contraction losses. Friction and contraction losses between sections 3 and 4 are calculated in the same way as friction and expansion losses between sections 1 and 2.

There are three methods available for computing losses through the bridge (sections 2 to 3):

- Energy Equation (standard step method)
- Momentum Balance
- Yarnell Equation

The user can select any or all of these methods in the computations. If more than one method is selected, the user must choose either a single method as the final solution or direct the program to use the method that computes the greatest energy loss through the bridge as the answer at section 3. This allows the modeler to compare the answers from several techniques all in a single execution of the program. Minimal results are available for all the methods computed, but detailed results are available for the method that is selected as the final answer. A detailed discussion of each method follows.

#### Energy Equation (standard step method):

The energy based method treats a bridge in the same manner as a natural river cross section, except the area of the bridge below the water surface is subtracted from the total area, and the wetted perimeter is increased where the water is in contact with the bridge structure. As described previously, the program formulates two cross sections inside the bridge by combining the ground information of sections 2 and 3 with the bridge geometry. As shown in Figure 2, for the purposes of discussion, these cross sections will be referred to as sections BD (Bridge Downstream) and BU (Bridge Upstream).

The sequence of calculations starts with a standard step calculation from just downstream of the bridge (section 2) to just inside of the bridge (section BD) at the downstream end. The program

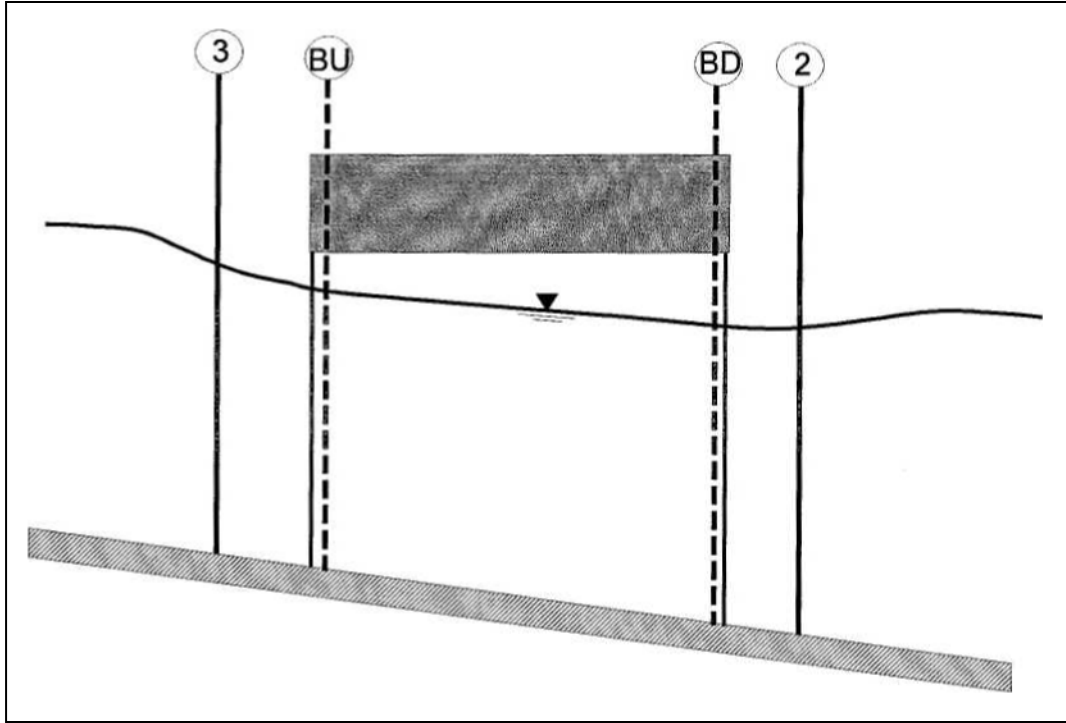

**Figure 2.** Cross Sections Near and Inside the Bridge

then performs a standard step through the bridge (from section BD to section BU). The last calculation is to step out of the bridge (from section BU to section 3).

Momentum Balance Method:

The momentum method is based on performing a momentum balance from cross section 2 to cross section 3. The momentum balance is performed in three steps. The first step is to perform a momentum balance from cross section 2 to cross section BD inside the bridge. The equation for this momentum balance is as follows:

$$A_{BD}\bar{Y}_{BD} + \frac{\beta_{BD}Q_{BD}^2}{gA_{BD}} = A_2\bar{Y}_2 - A_{p2}\bar{Y}_{p2} + \frac{\beta_2Q_2^2}{gA_2} + F_f - W_x \quad (1)$$

where:  $A_2, A_{BD}$  = active flow area at section 2 and BD, respectively

$A_{p2}$  = obstructed area of the pier on the downstream side

$\bar{Y}_2, \bar{Y}_{BD}$  = vertical distance from water surface to center of gravity of flow area  $A_2$  and  $A_{BD}$ , respectively

$\bar{Y}_{p2}$  = vertical distance from water surface to center of gravity of wetted pier area on downstream side

$\beta_2, \beta_{BD}$  = velocity weighting coefficients for momentum

- $Q_2, Q_{BD}$  = discharge  
 $g$  = gravitational acceleration  
 $F_f$  = force due to friction  
 $W_x$  = force due to weight of water in the direction of flow

The second step is a momentum balance from section BD to BU (see Figure 2). The equation for this step is as follows:

$$A_{BU}\bar{Y}_{BU} + \frac{\beta_{BU}Q_{BU}^2}{gA_{BU}} = A_{BD}\bar{Y}_{BD} + \frac{\beta_{BD}Q_{BD}^2}{gA_{BD}} + F_f - W_x \quad (2)$$

The final step is a momentum balance from section BU to section 3 (see Figure 2). The equation for this step is as follow:

$$A_3\bar{Y}_3 + \frac{\beta_3Q_3^2}{gA_3} = A_{BU}\bar{Y}_{BU} + \frac{\beta_{BU}Q_{BU}^2}{gA_{BU}} + A_{p3}\bar{Y}_{p3} + \frac{1}{2}C_D \frac{A_{p3}Q_3^2}{gA_3^2} + F_f - W_x \quad (3)$$

where:  $C_D$  = drag coefficient for flow going around the piers

The momentum method provides detailed output for the cross sections inside the bridge (BU and BD) as well as outside the bridge (2 and 3). The user has the option of turning the friction and weight force components off; the default is to include these two terms in the momentum balance.

#### Yarnell Equation:

The Yarnell equation is an empirical equation that is used to predict the change in water surface from just downstream of the bridge (section 2 of Figure 2) to just upstream of the bridge (section 3). The equation is based on approximately 2600 laboratory experiments in which the researchers varied the shape of the piers, the width, the length, the angle, and the flow rate. The Yarnell equation is as follows (Yarnell, 1934):

$$H_{3-2} = 2K(K + 10\omega - 0.6)(\alpha + 15\alpha^4) \frac{V_2^2}{2g} \quad (4)$$

where:  $H_{3-2}$  = the drop in water surface from section 3 to 2

$K$  = Yarnell's pier shape coefficient

$\omega$  = ratio of velocity head to depth at section 2

$\alpha$  = obstructed area of the piers divided by the total unobstructed area

$V_2$  = velocity downstream at section 2

The computed upstream water surface elevation is simply the downstream water surface elevation plus  $H_{3-2}$ . With the upstream water surface known, the program computes the corresponding velocity head and energy elevation for the upstream section (section 3). When the Yarnell method is used, hydraulic information is only provided at cross sections 2 and 3 (no information is provided for sections BU and BD).

The Yarnell equation is sensitive to the pier shape (K coefficient), the pier obstructed area, and the velocity of the water. The method is not sensitive to the shape of the bridge opening, the shape of the abutments, or the width of the bridge. Because of these limitations, the Yarnell method should only be used at bridges where the majority of the energy losses are associated with the piers.

**Class B low flow.** Class B low flow can exist for either subcritical or supercritical profiles. For either profile, class B flow occurs when the profile passes through critical depth in the bridge constriction. For a **subcritical profile**, the momentum equation or the energy equation can be used to compute an upstream water surface (section 3 of Figure 2) above critical depth and a downstream water surface (section 2) below critical depth. For a **supercritical profile**, the bridge is acting as a control and is causing the upstream water surface elevation to be above critical depth. Momentum or energy can be used to calculate an upstream water surface above critical depth and a downstream water surface below critical depth. If the user is running a mixed flow regime profile, the program will proceed with backwater calculations upstream, and later with forewater calculations downstream from the bridge.

Whenever class B flow is found to exist, the user should run the program in a mixed flow regime mode. The mixed flow regime mode is capable of calculating a subcritical profile upstream from the bridge and a supercritical profile downstream from the bridge. Also, any hydraulic, jumps can be located, if they exist.

**Class C low flow.** Class C low flow exists when the water surface through the bridge is completely supercritical. The program can use either the energy equation or the momentum equation to compute the water surface through the bridge for this class of flow.

### *High Flow Computations*

The HEC-RAS program has the ability to compute high flows (flows that come into contact with the maximum low chord of the bridge deck) by either the Energy equation (standard step method) or by using separate hydraulic equations for pressure and/or weir flow. The two methodologies are explained below.

### Energy Equation (standard step method):

The Energy based method is applied to high flows in the same manner as it is applied to low flows. Computations are based on balancing the energy equation in three steps through the bridge. Energy losses are based on friction and contraction and expansion losses. Output from this method is available at the cross sections inside the bridge as well as outside.

As mentioned previously, friction losses are based on the use on Manning's equation. Contraction and expansion losses are based on a coefficient multiplied by the absolute change in velocity head. The Energy based method performs all computations as though they are open channel flow. At the cross sections inside the bridge, the area obstructed by the bridge piers, abutments, and deck is subtracted from the flow area and additional wetted perimeter is added. Occasionally the resulting water surfaces inside the bridge (at sections BU and BD) can be computed at elevations that would be inside of the bridge deck. The water surfaces inside of the bridge reflect the hydraulic grade line elevations, not necessarily the actual water surface elevations.

### Pressure and Weir Flow Method:

A second approach for the computation of high flows is to utilize separate hydraulic equations to compute the flow as pressure and/or weir flow. The two types of flow are presented below.

**Pressure Flow Computations.** Pressure flow occurs when the flow comes into contact with the low chord of the bridge. Once the flow comes into contact with the upstream side of the bridge, a backwater occurs and orifice flow is established. The program will handle two cases of orifice flow; the first is when only the upstream side of the bridge is in contact with the water; and the second is when the bridge constriction is flowing completely full. The HEC-RAS program will automatically select the appropriate equation, depending upon the flow situation. For the first case (Figure 3), a sluice gate type of equation is used (FHWA, 1978):

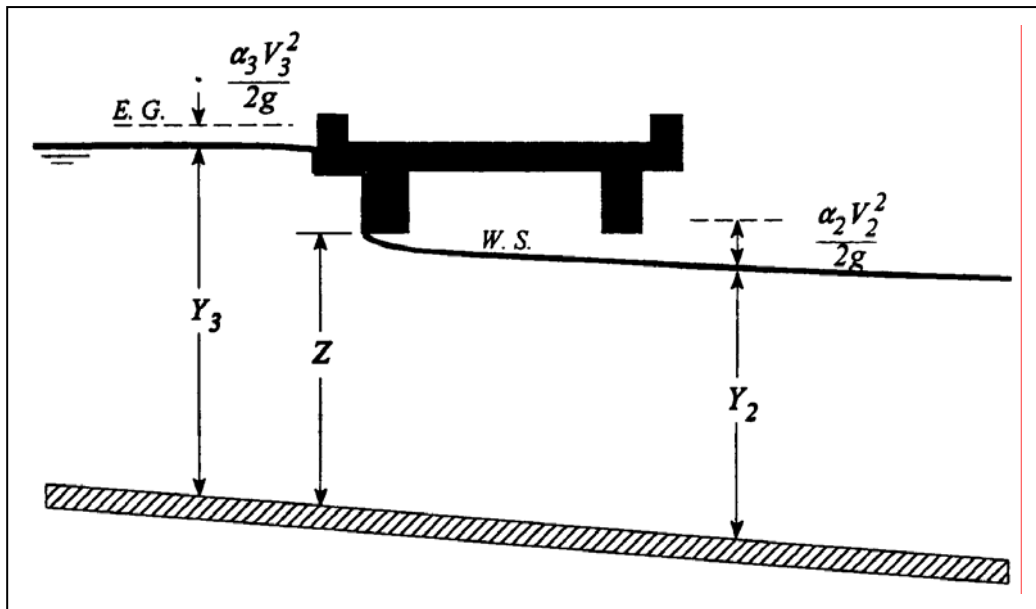

**Figure 3.** Example of a bridge under sluice gate type of pressure flow



$$Q = C_d A_{BU} \left[ 2g \left( Y_3 - \frac{Z}{2} + \frac{\alpha_3 V_3^2}{2g} \right) \right]^{\frac{1}{2}} \quad (5)$$

where:  $Q$  = total discharge through the bridge opening

$C_d$  = coefficient of discharge for pressure flow

$A_{BU}$  = net area of the bridge opening at section BU

$Y_3$  = hydraulic depth at section 3

$Z$  = vertical distance from maximum bridge low chord to the mean river bed elevation at section BU

The discharge coefficient  $C_d$ , can vary depending upon the depth of water upstream. Values for  $C_d$  range from 0.35 to 0.5, with a typical value of 0.5 commonly used in practice. The user can enter a fixed value for this coefficient or the program will compute one based on the amount that the inlet is submerged. A diagram relating  $C_d$  to  $Y_3/Z$  is shown in Figure 4.

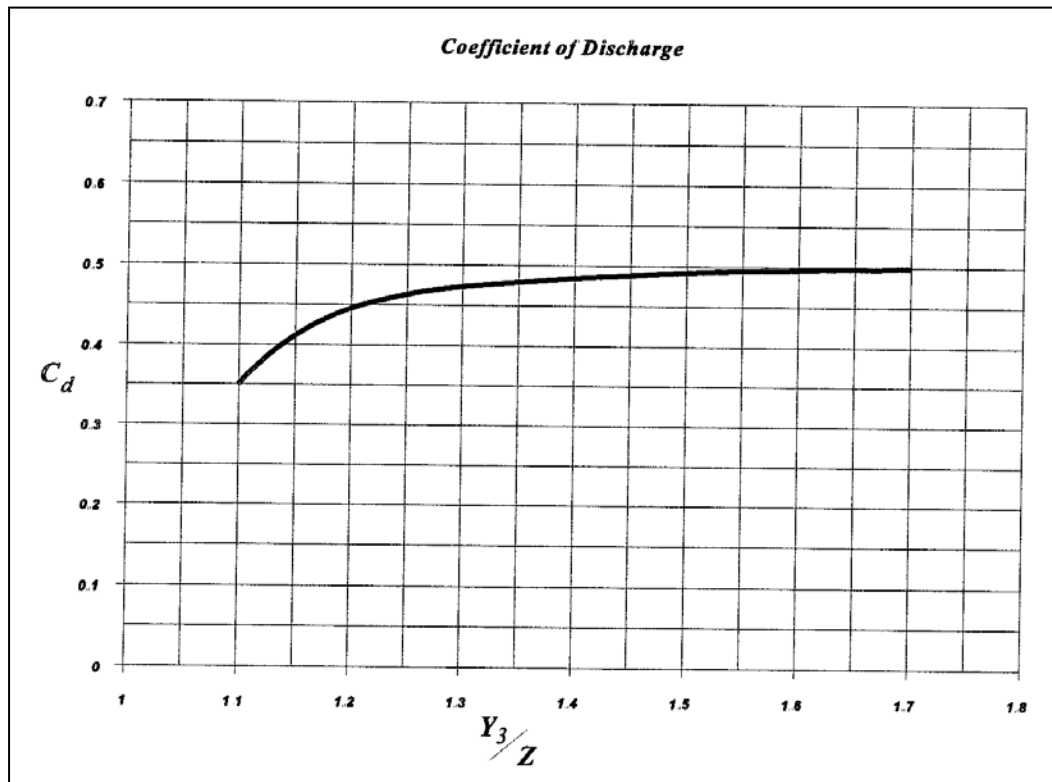

**Figure 4.** Coefficient of discharge for sluice gate type flow

As shown in Figure 4, the limiting value of  $Y_3/Z$  is 1.1. There is a transition zone somewhere between  $Y_3/Z = 1.0$  and 1.1 where free surface flow changes to orifice flow. The type of flow in this range is unpredictable, and equation 5 is not applicable.

In the second case, when both the upstream and downstream side of the bridge is submerged, the standard full flowing orifice equation is used (Figure 5). This equation is as follows:

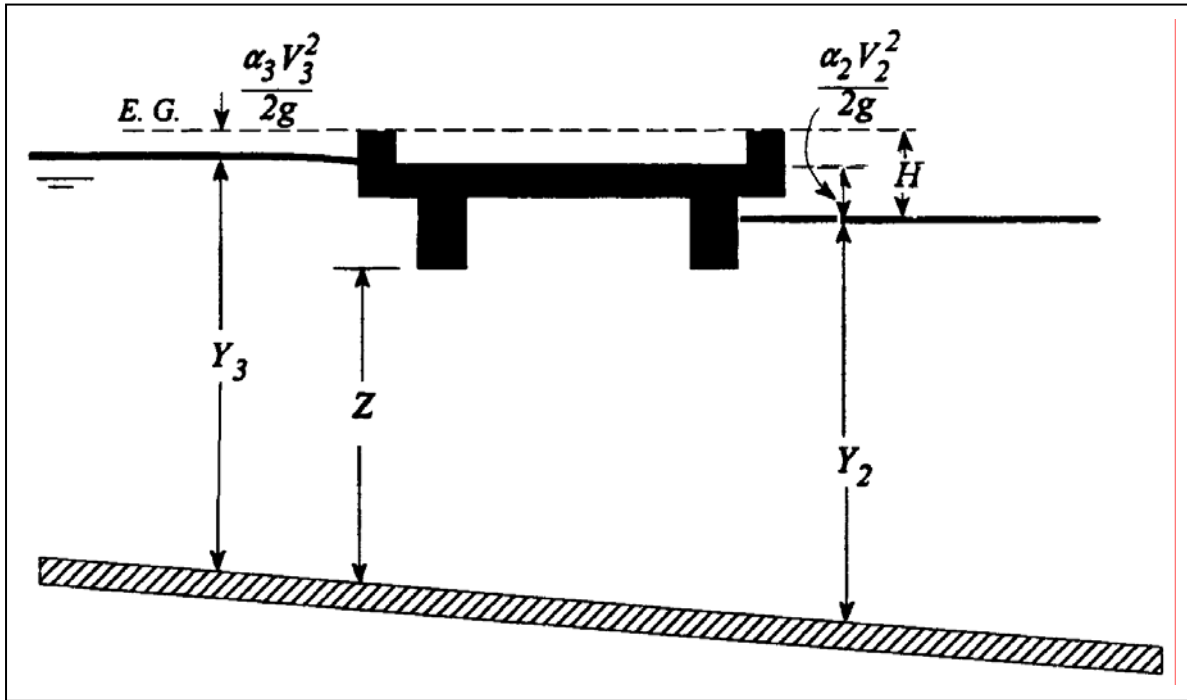

**Figure 5.** Example of a bridge under fully submerged pressure flow

$$Q = CA\sqrt{2gH} \quad (6)$$

where: C = coefficient of discharge for fully submerged pressure flow. Typical value of C is 0.8.

H = the difference between the energy gradient elevation upstream and the water surface elevation downstream

A = net area of the bridge opening

Typical values for the discharge coefficient C range from 0.7 to 0.9, with a value of 0.8 commonly used for most bridges. The user must enter a value for C whenever the pressure flow method is selected. The discharge coefficient C can be related to the total loss coefficient, which comes from the form of the orifice equation that is used in the HEC-2 computer program (HEC, 1991):

$$Q = \sqrt{\frac{2gH}{K}} \quad (7)$$

where: K = total loss coefficient

The conversion from K to C is as follows:

$$C = \sqrt{\frac{1}{K}} \quad (8)$$

The program will begin checking for the possibility of pressure flow when the computed low flow energy grade line is above the maximum low chord elevation at the upstream side of the bridge. The user has the option to tell the program to use the water surface, instead of energy, to trigger the pressure flow calculation. Once pressure flow is computed, the pressure flow answer is compared to the low flow answer; the higher of the two is used.

**Weir Flow Computations.** Flow over the bridge, and the roadway approaching the bridge is calculated using the standard weir equation (Figure 6):

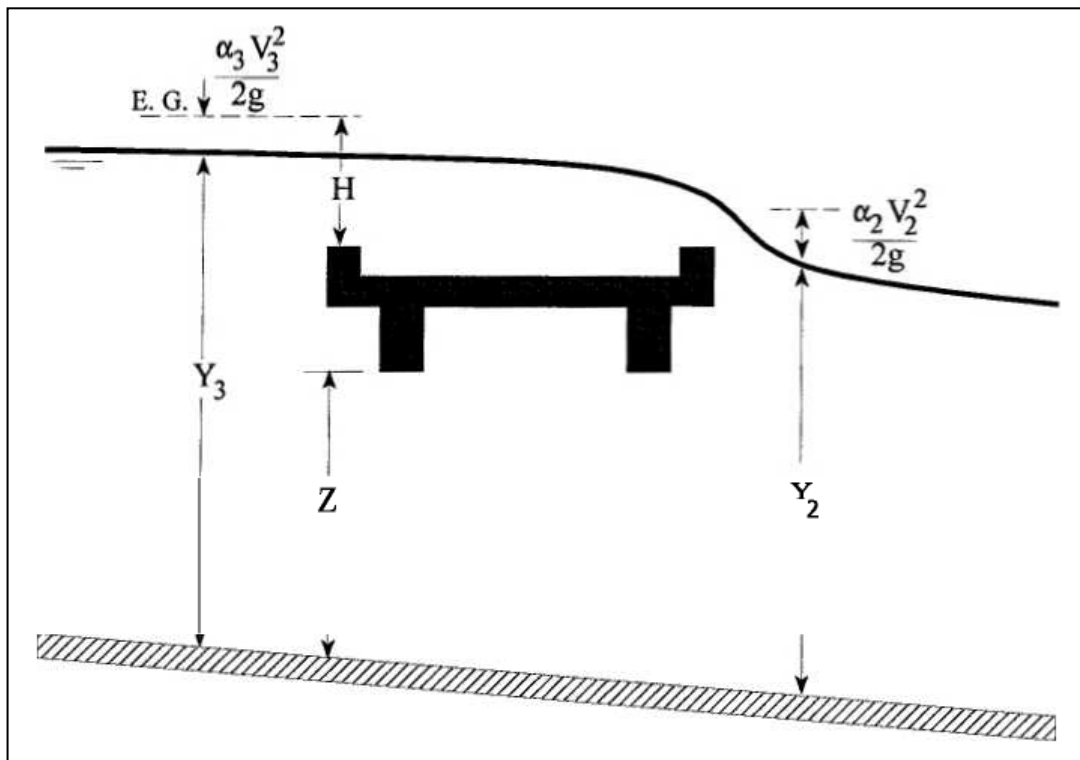

**Figure 6.** Example bridge with pressure and weir flow

$$Q = CLH^{3/2} \quad (9)$$

where: Q = total flow over the weir

C = coefficient of discharge for weir flow

L = effective length of the weir

H = difference between energy upstream and road crest

The approach velocity is included by using the energy grade line elevation in lieu of the upstream water surface elevation for computing the head, H.

For high tailwater elevations, the program will automatically reduce the amount of weir flow to account for submergence on the weir. This is accomplished by reducing the weir coefficient based on the amount of submergence. Submergence corrections are based on a trapezoidal weir shape or optionally an ogee spillway shape. The total weir flow is computed by subdividing the weir crest into segments, computing L, H, a submergence correction, and a Q for each section, then summing the incremental discharges. The submergence correction for a trapezoidal weir shape is from "Hydraulics of Bridge Waterways" (Bradley, 1978). Figure 7 shows the relationship between the percentage of submergence and the flow reduction factor. The percent of submergence is computed as the depth of the tailwater above the weir divided by the upstream energy head above the weir, times 100.

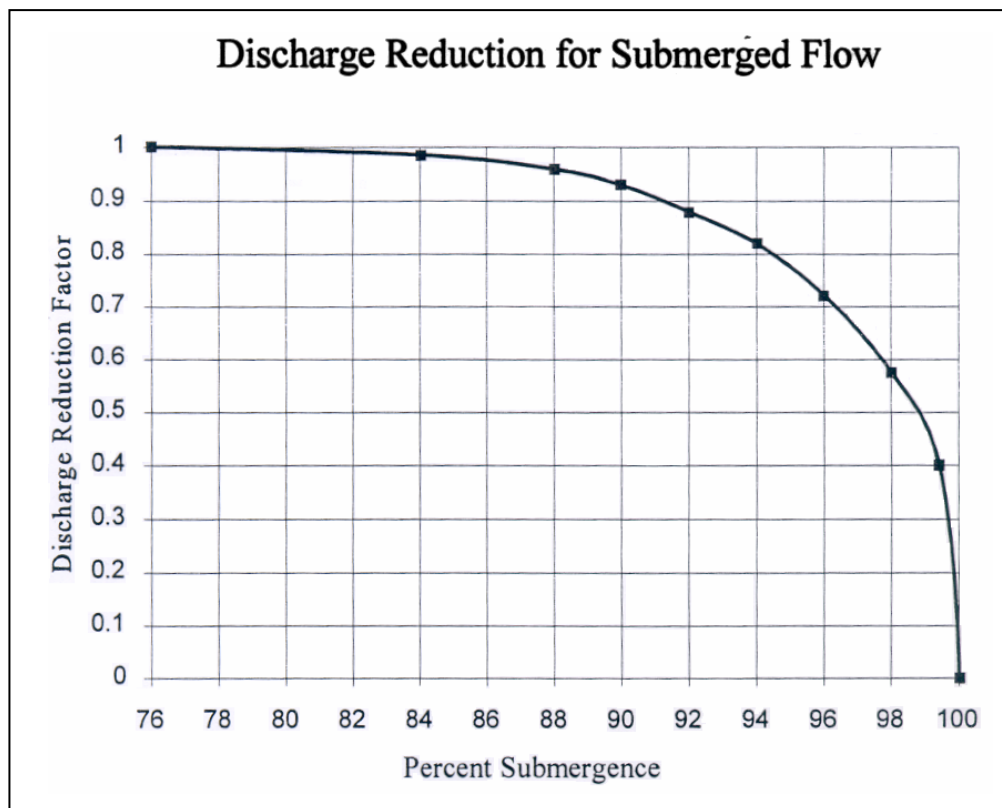

**Figure 7.** Factor for reducing weir flow for submergence

When the weir becomes highly submerged the program will automatically switch to calculating the upstream water surface by the energy equation (standard step backwater) instead of using the pressure and weir flow equations. The criterion for switching to energy based calculations is user controllable. A default maximum submergence is set to 0.95 (95 percent).

#### *Combination Flow*

Sometimes combinations of low flow or pressure flow occur with weir flow. In these cases, an iterative procedure is used to determine the amount of each type of flow. The program continues

to iterate until both the low flow method (or pressure flow) and the weir flow method have the same energy (within a specified tolerance) upstream of the bridge (section 3). The combination of low flow and weir flow can be computed with any of the low flow methods mentioned previously, except the momentum based method.

## HEC-2

HEC-2 computes energy losses caused by structures such as bridges in two parts. One part consists of the losses that occur in reaches immediately upstream and downstream from the bridge where contraction and expansion of the flow is taking place. The second part consists of losses at the structure itself and is calculated with either the normal bridge method or the special bridge method. Cross section locations are the same as described previously for HEC-RAS.

Losses due to contraction and expansion of flow between cross sections are determined by standard-step profile calculations. Manning's equation is used to calculate friction losses, and all other losses are described in terms of a coefficient multiplied by the absolute value of the change in velocity head between adjacent cross sections.

### Normal Bridge Method

The normal bridge method handles a bridge cross section in the same manner as a natural river cross section, except that the area of the bridge below the water surface is subtracted from the total area, and the wetted perimeter is increased where the water is in contact with the bridge structure. The user is required to enter the two cross sections inside the bridge. The bridge deck is described either by entering the constant elevations of the top of roadway and low chord, or by specifying a table of roadway stations and elevations, and corresponding low chord elevations. Pier losses are accounted for by the loss of area and the increased wetted perimeter of the piers, as described in terms of cross section coordinates.

### Special Bridge Method

The special bridge method computes losses through the structure for low flow, pressure flow, weir flow, or for a combination of these. The profile through the bridge is calculated using hydraulic formulas to determine the change in energy and water surface elevation through the bridge.

**Low Flow.** The procedure used for low flow calculations in the special bridge method depends on whether the bridge has piers. **Without piers**, the low flow solution is accomplished by standard-step calculations as in the normal bridge method. The transfer to the normal bridge method is necessary because the equations used in the special bridge method for **low flow** are based on the obstruction width due to the piers. Without piers, the special bridge solution would indicate that no losses would occur.

For a bridge **with piers**, the program goes through a momentum balance for cross sections just outside and inside the bridge to determine the class of flow. The momentum calculations are

handled by employing the following momentum relations based on the equations proposed by Koch-Carstanjen [Eichert/Peters, 1970] [Koch-Carstanjen, 1962].

$$m_1 - m_{p1} + \frac{Q^2}{g(A_1)^2} \left( A_1 - \frac{C_D}{2} A_{p1} \right) = m_2 + \frac{Q^2}{gA_2} = m_3 - m_{p3} + \frac{Q^2}{gA_3} \quad (10)$$

- where:  $A_1, A_3$  = flow areas at upstream and downstream sections, respectively
- $A_2$  = flow area (gross area - area of piers) at a section within constricted reach
- $A_{p1}, A_{p3}$  = obstructed areas at upstream and downstream sections, respectively
- $\bar{y}_1, \bar{y}_2, \bar{y}_3$  = vertical distance from water surface to center of gravity of  $A_1, A_2, A_3$ , respectively
- $m_1, m_2, m_3$  =  $A_1 \bar{y}_1, A_2 \bar{y}_2$  and  $A_3 \bar{y}_3$ , respectively
- $m_{p1}, m_{p3}$  =  $A_{p1} \bar{y}_{p1}$  and  $A_{p3} \bar{y}_{p3}$ , respectively
- $C_D$  = drag coefficient equal to 2.0 for square pier ends and 1.33 for piers with semicircular ends
- $\bar{y}_{p1}, \bar{y}_{p3}$  = vertical distance from water surface to center of gravity of  $A_{p1}$  and  $A_{p3}$ , respectively
- $Q$  = discharge
- $g$  = gravitational acceleration

The three parts of the momentum equation represent the total momentum flux in the constriction expressed in terms of the channel properties and flow depths upstream, within and downstream of the constricted section. If each part of this equation is plotted as a function of the water depth, three curves are obtained representing the total momentum flux in the constriction for various depths at each location. The desired solutions (water depths) are then readily available for any class of flow. The momentum equation is based on a trapezoidal section and therefore requires a trapezoidal approximation of the bridge opening.

**Class A low flow** occurs when the water surface through the bridge is above critical depth, i.e., subcritical flow. The special bridge method uses the Yarnell equation for this class of flow to determine the change in water surface elevation through the bridge. As in the momentum calculations, a trapezoidal approximation of the bridge opening is used to determine the areas.

$$H_3 = 2K(K + 10\omega - 0.6)(\alpha + 15\alpha^4) \frac{V_3^2}{2g} \quad (11)$$

- where:  $H_3$  = drop in water surface from upstream to downstream sides of the bridge
- $K$  = pier shape coefficient
- $\omega$  = ratio of velocity head to depth downstream from the bridge obstructed area
- $\alpha$  = total unobstructed area
- $V_3$  = velocity downstream from the bridge

The computed upstream water surface elevation is simply the downstream water surface elevation plus  $H_3$ . With the upstream water surface elevation known, the program computes the corresponding velocity head and energy elevation for the upstream section.

**Class B low flow** can exist for either a subcritical or supercritical profile. For either profile, class B low flow occurs when the profile passes through critical depth in the bridge constriction. For a **subcritical profile**, critical depth is determined in the bridge, a new downstream depth (below critical) and the upstream depth (above critical) are calculated by finding the depths whose corresponding momentum fluxes equal the momentum flux in the bridge for critical depth. The program does not provide the location of the hydraulic jump. A supercritical profile could be computed starting at the downstream section with a water surface elevation  $X$ . For a **supercritical profile**, the bridge is acting as a control and is causing the upstream water surface elevation to be above critical depth. Momentum equations are again used to recompute an upstream water surface elevation (above critical) and a downstream elevation below critical depth.

**Class C low flow** is computed for a supercritical profile where the water surface profile stays supercritical through the bridge constriction. The downstream depth and the depth in the bridge are computed by the momentum equations based on the momentum flux in the constriction and the upstream depth.

**Pressure Flow.** The pressure flow computations use the orifice flow equation of U.S. Army Engineer Manual 1110-2-1602, "Hydraulic Design of Reservoir Outlet Structures," [USACE, 1963].

$$Q = A \sqrt{\frac{2gH}{K}} \quad (12)$$

- where:  $H$  = difference between the energy gradient elevation upstream and tailwater elevation downstream
- $K$  = total loss coefficient
- $A$  = net area of the orifice

g = gravitational acceleration

Q = total orifice flow

The total loss coefficient, K, for determining losses between the cross sections immediately upstream and downstream from the bridge, is equal to 1.0 plus the sum of loss coefficients for intake, intermediate piers, friction, and other minor losses. The section on loss coefficients provides values for the total loss coefficient and shows the derivation of the equation and the definition of the loss coefficient.

**Weir Flow.** Flow over the bridge and the roadway approaching the bridge is calculated using the standard weir equation:

$$Q = CLH^{3/2} \quad (13)$$

where: C = coefficient of discharge

L = effective length of weir controlling flow

H = difference between the energy grade line elevation and the roadway crest elevation

Q = total flow over the weir

The approach velocity is included by using the energy grade line elevation in lieu of the upstream water surface elevation for computing the head, H. Where submergence by tailwater exists, the coefficient 'C' is reduced by the program [Bradley, 1978]. Submergence corrections are based on a trapezoidal weir shape or optionally an ogee spillway shape. A total weir flow, Q, is computed by subdividing the weir crest into segments, computing L, H, a submergence correction and Q for each segment, and summing the incremental discharges.

**Combination Flow.** Sometimes combinations of low flow or pressure flow occur with weir flow. In these cases a trial and error procedure is used, with the equations just described, to determine the amount of each type of flow. The procedure consists of assuming energy elevations and computing the total discharge until the computed discharge equals, within 1 percent, the discharge desired.

## WSPRO

WSPRO computes the water surface profile through a bridge by solving the energy equation. Cross sections are located as shown in Figure 8.

Computations of the water surface profile require the user to enter a minimum of four cross sections. These include sections 4, 3F, 3, and 1. Sections 4, 3F, and 1 are unconstricted full valley sections, while section 3 is the bridge opening section. Cross section 2 represents an



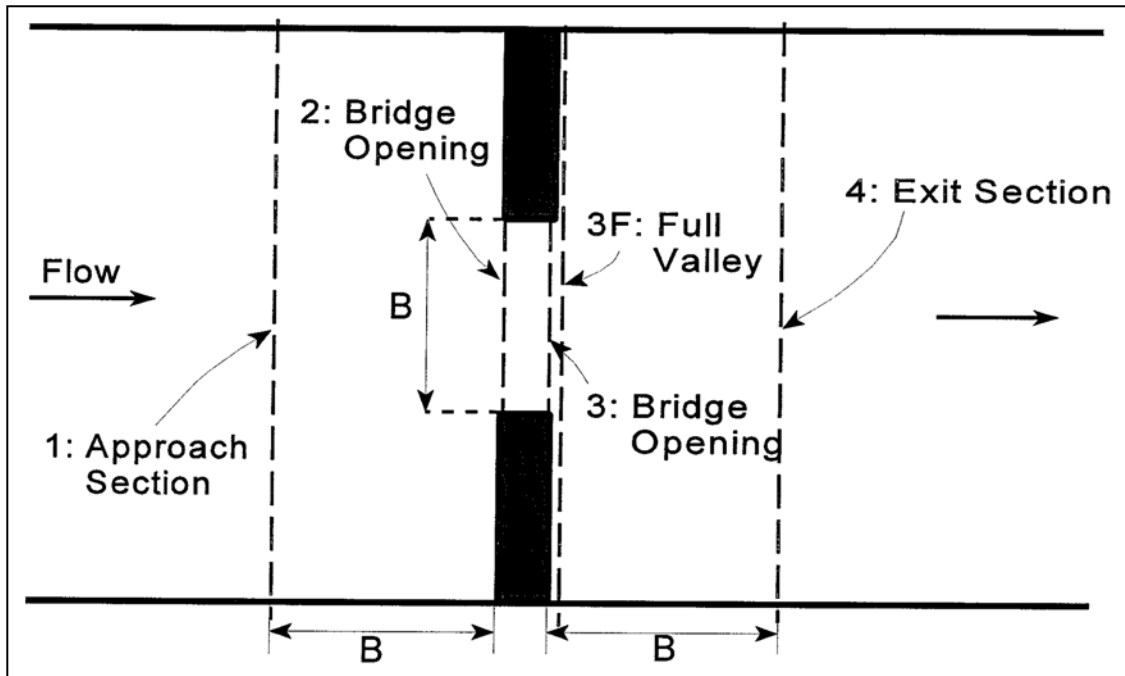

**Figure 8.** Cross section locations for WSPRO bridge hydraulics

additional control point in the computations, but requires no data. Section 2 will be assumed to be the same as section 3, unless the user enters a separate cross section for that location.

The WSPRO program first computes a natural profile (no bridge structure) by performing a standard step calculation from section 4 (exit section) to section 3F (full valley section); then from section 3F to section 1 (approach section). The program then computes the profile with the bridge in place. In this case the energy balance is performed from section 4 to 3 (bridge opening); then from section 3 to 2 (upstream bridge opening); and finally from 2 to 1. The total energy equation from the exit to the approach section can be written as follows:

$$h_1 + \frac{V_1^2}{2g} = h_4 + \frac{V_4^2}{2g} + h_{L(1-4)} \quad (14)$$

where:  $h_1$  = water surface elevation at section 1

$V_1$  = velocity at section 1

$h_4$  = water surface elevation at section 4

$V_4$  = velocity at section 4

$h_L$  = energy losses from section 1 to 4

Energy losses from section 1 to 4 are equal to friction losses from 1 to 4 and an expansion loss from 3 to 4. The incremental losses are calculated as follows:

### From Section 4 to 3

Losses from section 4 to section 3 are based on friction losses and an expansion loss. Friction losses are calculated using the geometric mean friction slope times the straight line distance between sections 3 and 4 (distance B from Figure 8). The following equation is used for friction losses from 3 to 4:

$$h_{f(3-4)} = \frac{BQ^2}{K_3K_4} \quad (15)$$

Where  $K_3$  and  $K_4$  are the total conveyance at sections 3 and 4 respectively. The expansion loss from section 3 to section 4 is computed by the following equation:

$$h_e = \frac{Q^2}{2gA_4^2} \left[ 2\beta_4 - \alpha_4 - 2\beta_3 \left( \frac{A_4}{A_3} \right) + \alpha_3 \left( \frac{A_4}{A_3} \right)^2 \right] \quad (16)$$

Where  $\alpha$  and  $\beta$  are energy and momentum correction factors for non-uniform flow.  $\alpha_4$  and  $\beta_4$  are computed as follows:

$$\alpha_4 = \frac{\sum \left( \frac{K_i^3}{A_i^2} \right)}{\frac{K_T^3}{A_T}} \quad (17)$$

$$\beta_4 = \frac{\sum \left( \frac{K_i^2}{A_i} \right)}{\frac{K_T^2}{A_T}} \quad (18)$$

$\alpha_3$  and  $\beta_3$  are related to the bridge geometry and are defined as follows:

$$\alpha_3 = \frac{1}{C^2} \quad (19)$$

$$\beta_3 = \frac{1}{C} \quad (20)$$

Where C is an empirical discharge coefficient for the bridge, which was developed as part of the Contracted Opening method by Kindswater, Carter, and Tracy (USGS, 1953).

### From Section 2 to 3

Energy losses from section 2 to 3 (through the bridge) are based on friction losses only. The following equation is used for calculating the friction loss:

$$h_{f(2-3)} = L_{(2-3)} \left( \frac{Q}{K_3} \right)^2 \quad (21)$$

Where  $L_{(2-3)}$  is the distance between the bridge sections, and  $K_3$  is the conveyance at section 3 inside the bridge.

### From Section 1 to 2

Energy losses from section 1 to 2 are based on friction losses only. The equation for computing the friction loss is as follows:

$$h_{f(1-2)} = \frac{L_{av} Q^2}{K_1 K_c} \quad (22)$$

Where  $L_{av}$ , is the effective flow length in the approach reach, and  $K_c$  is the minimum of the conveyances inside the bridge. The effective flow length is computed as the average length of 20 equal conveyance stream tubes (FHWA, 1990).

**Pressure flow** and **weir flow** are modeled in a similar manner as in the HEC-RAS software.

## Model Development

Because this study is a comparison between models, it is very important that the geometric data and model parameters be developed in a consistent manner. The key pieces of information are: cross-section geometry and location; Manning's n values; reach lengths (left overbank, main channel, and right overbank); contraction and expansion coefficients; bridge geometry; ineffective flow areas; and the location of the main channel bank stations. Each of the models were developed using the same data where possible (i.e., the same cross sections and locations, the same n values, bridge geometry, etc.). The only differences between the models were the required coefficients that are used in solving the hydraulic equations in the vicinity of the bridge. This will be discussed in further detail under the description of model calibration.

### Cross Section Data and Locations

At all of the bridge sites, the corresponding hydrologic atlas provided cross section data that was surveyed at equal intervals along the stream, both sufficiently upstream and downstream from the bridge sites. Each data set included no fewer than eight cross sections. Additional cross sections were also surveyed just downstream of the bridge and inside the bridge. In general, the surveyed cross sections were used at the locations provided. In addition to the surveyed cross

sections, it was necessary to locate cross sections in the vicinity of the bridge, as required by the various models. These cross sections consisted of: an exit section (section 1 from Figure 1); a cross section upstream of the bridge (section 3 from Figure 1); and an approach section (section 4 from Figure 1). The cross sections were formulated by making a copy of the closest surveyed section, and then making any minor adjustments to the station and elevation points if needed.

There is some question about the sharpness of the contraction and re-expansion of effective flow in the immediate vicinity of a bridge, and indeed this concept is an integral part of the bridge modeling methodologies. For this study, almost all of the models are based on the assumption that both the contraction and expansion reaches have a length equal to the width of the bridge waterway opening. Because this assumption is a requirement in the WSPRO model, the approach and exit cross sections were placed at the same locations in HEC-RAS and HEC-2. This was done in order to have consistency between the models. In addition, for these specific sites the assumption of one bridge opening width for the expansion and contraction reach lengths appears to give reasonable results. However, for three of the events, it was found that improved results could be achieved by moving the exit section to a greater distance downstream from the bridge. This was done for both HEC-RAS and HEC-2.

## **Manning's n Values**

The USGS hydrologic atlases contain color coded land use maps for the area of the floodplain. Each color is assigned a range of values for the Manning roughness coefficient. The maps also recommend using the high end of the range for depths below 0.6 meters, the low end of the range for flow depths above 1.0 meter, and linear interpolation between those two depths.

The approach for selecting n values was to have only as many different n values in the model as there are roughness types on the maps. The only exception to this is where the channel and the overbanks have been coded with the same roughness type, and the channel flow depth is much greater than the overbank depth. We faithfully tried to represent the information in the atlases as much as possible in the models, with respect to where changes in the n values can be expected to occur.

## **Channel Bank Stations and Reach Lengths**

In some of the study reaches, the atlases delineate the low-flow channel on the planimetric view of the atlas. The models for these reaches have the section bank stations set to correspond with the atlas low-flow channel, even at sections where this alleged channel does not include the lowest point in the cross section. For those sites that did not indicate a low-flow channel location, bank stations have been set at each section generally to include the sharpest and deepest incision in the channel, except where this incision appears to be a tributary channel. In many of these cases, the bank station settings are inconsequential since a uniform n value has been used across the section.

Channel reach lengths for the models were scaled from the atlases. The main channel reach lengths were measured along the invert of the main channel. The overbank reach lengths were measured along the perceived path of the center of mass of the overbank flow. In general, the

center of mass of the overbanks was estimated as being 1/3 the distance from the main channel bank station to the edge of the water surface boundary.

## **Cross Section Effective Flow Area**

For the sections immediately adjacent to bridges and those which incorporate an apparent area of 'dead water', the effective flow area at the cross section has been constrained within the floodplain. In most cases this has been done in a manner which accomplished the constraint without adding wetted perimeter at the effective flow boundaries, using the assumption that a water-to-water boundary induces no significant friction loss. Two methods can be used which have this effect: using extremely high  $n$  values in the ineffective areas ( $n = 100$ ); or using the program's ineffective flow option.

## **Bridge Crossing Geometry**

Detailed information about the bridge (road embankment, bridge deck, abutments, and piers) was well documented in each of the USGS hydrologic atlases. Each atlas contained a surveyed cross section inside the bridge, as well as detailed drawings of the bridge opening. This information was used consistently between all of the computer programs.

## **Model Calibration**

At all of the study sites, reach geometry, discharge, and observed water surface data are given far enough downstream that a profile starting point can be selected which is outside of the influence of the bridge. The main calibration parameter in all of the models was Manning's  $n$  values. Contraction and expansion coefficients were also estimated.

## **Manning's $n$ Values**

Calibration of Manning's  $n$  values was done using the entire observed extent of each reach. Exceptions to this are reaches where there was a significant inaccuracy in the downstream portions of the model, which could not be rectified by reasonable calibration. It was suspected that some important changes in roughness existed which were not documented on the atlas. In such cases, the starting point was moved upstream beyond the troublesome spot. The calibration of  $n$  values was done by raising or lowering the  $n$  values of the entire reach. There are some locations in the models where a change in the  $n$  value at a specific cross section would produce a much better fit to the observed data, but no indication is given in the atlas that the roughness has changed for that cross section. In these cases, we did not change the  $n$  value. In other words, we have avoided a section-by-section calibration of  $n$  values, since to calibrate  $n$  values in this way would produce a model where all other parameter effects are masked. All changes in  $n$  values, within a particular model, were constrained to the  $n$  value ranges provided by the atlases. Also, the same  $n$  values were used in each of the three models for the same data set.

All the models involved in the study incorporate the set of  $n$  values which, following the basic rules mentioned above, provide the best fit to the observed data over the entire reach, with

greater weight given to those portions of the reach not likely to be affected by the bridge (cross sections downstream of the exit section). The final  $n$  values were set after we were confident that the reach geometry was modeled reasonably based on the atlases.

## **Contraction and Expansion Coefficients**

In general, contraction and expansion coefficients were set to 0.1 and 0.3 respectively. There is some uncertainty about the proper values for these coefficients in the vicinity of a bridge. At most of the sites in our study, the velocity heads are low, even at the bridge. Therefore the setting of these parameters had little effect on the solution. We have considered this to be an allowable calibration variable at the bridge with two possible discreet settings:

1. Contraction Coefficient = 0.3 and Expansion Coefficient = 0.5, or
2. Contraction Coefficient = 0.5 and Expansion Coefficient = 0.8

For most of the bridge sites, values of 0.3 and 0.5 were used for the contraction and expansion coefficients, respectively. In general, the setting of the contraction and expansion coefficients did not influence the results to any significant degree, for these specific data sets.

## **Final Model Adjustments**

Once the calibration of  $n$  values and contraction and expansion coefficients was completed, the performance evaluation and model comparison was carried out by selecting the downstream starting cross section as that section which is nearest to, yet outside of, the assumed expansion reach downstream of the bridge. The starting water surface was set to the observed value at this location in order to ensure that any differences between computed and observed water surface elevations in the vicinity of the bridge were due solely to the bridge computations. For most of the models the downstream starting section was the exit section. In a few of the models it was necessary to set the starting water surface elevation at the cross section just downstream of the exit section. This was done, for these sites, because the observed water surface information in the vicinity of the exit section was inconclusive. Therefore, it was deemed that it would be better to start at the next downstream section with a better known water surface elevation.

## **Modeling Results**

During the course of this study it was found that for HEC-RAS and HEC-2, the energy based bridge solution methods (Normal Bridge for HEC-2) consistently produced better results than any of the other methods available in these models. This is consistent with the fact that friction losses are the predominant factor in the change in energy through the bridges at these specific locations. Because of this, the results shown for HEC-RAS and HEC-2 are only for the energy based solution methods.

The results from this study are presented in the form of tables and graphics. Table 1 shows summary results for all of the events at all of the bridge sites modeled. This table shows

observed and computed water surface elevations at the approach section (section 4 from Figure 1) of each bridge.

**Table 1**  
**Computed and Observed Water Surface Elevation at the Approach Section**

Study Location	Flow (cfs)	Observed WSEL (ft)	HEC-RAS		HEC-2		WSPRO	
			WSEL (ft)	Error (ft)	WSEL (ft)	Error (ft)	WSEL (ft)	Error (ft)
Alexander Cr.	5508	88.4	88.2	-0.2	88.1	-0.3	88.3	-0.1
Alexander Cr.	9500	90.2	90.1	-0.1	90.0	-0.2	90.1	-0.1
Beaver Cr.	14000	217.8	217.9	0.1	217.8	0.0	217.3	-0.5
Bogue Chitto	25000	337.3	337.8	0.5	337.5	0.2	337.6	0.3
Bogue Chitto	31500	338.3	338.9	0.6	338.5	0.2	338.8	0.5
Buckhorn Cr.	4150	322.0	322.1	0.1	322.2	0.0	322.3	0.3
Cypress Cr.	1500	116.1	115.8	-0.3	115.7	-0.4	115.9	-0.2
Flagon Bayou	4730	76.3	76.2	-0.1	76.2	-0.1	76.9	0.6
Okatama Cr. near Magee	16100	367.2	367.3	0.1	367.1	-0.1	367.3	0.1
Okatama Cr. East of Magee	12100	371.9	371.5	-0.4	371.5	-0.4	372.6	0.7
Pea Cr.	1780	359.1	358.9	-0.2	358.8	-0.3	359.4	0.3
Poley Cr.	1900	234.8	234.7	-0.1	234.6	-0.2	235.0	0.2
Poley Cr.	4600	237.2	237.2	0.0	237.2	0.0	237.6	0.4
Tenmile Cr.	6400	110.9	111.0	0.1	111.0	0.1	110.9	0.0
Thompson Cr.	3800	200.3	200.6	0.3	200.6	0.3	200.9	0.6
Yellow River	2000	234.2	234.2	0.0	234.1	-0.1	234.3	0.1
Yellow River	6603	237.3	237.7	0.4	237.5	0.2	237.8	0.5
<b>Average Absolute Error</b>				0.21		0.18		0.32

Table 2 shows the average absolute error in water surface elevations based on a comparison of three locations at each bridge site. These locations were: just downstream of the bridge; at the approach section; and, the next cross section upstream of the approach section. The average absolute error at each location is computed by taking the sum of the absolute value of the computed minus observed water surface at the three locations, then dividing by three.

In addition to Table 1 and Table 2, Appendix B includes a separate table and graphic for each of the bridge sites. The tables include observed and computed water surface elevations at several locations. An example of this output is shown in Figure 9 and Table 3. Figure 9 shows the observed and computed water surface profile results for the Poley Creek bridge site. Table 3 has the corresponding numerical results.

## Summary and Conclusions

The purpose of this study was to evaluate the effectiveness of the HEC-RAS bridge modeling approaches at sites with extensive observed data, and to compare HEC-RAS with HEC-2 and WSPRO with respect to bridge modeling performance. Data were collected from the USGS in

**Table 2**  
**Average Absolute Error in Water Surface Elevation Based on Three Locations**

Study Location	Flow (cfs)	HEC-RAS		HEC-2		WSPRO	
		Rank	Ave Abs Error(ft)	Rank	Ave Abs Error (ft)	Rank	Ave Abs Error (ft)
Alexander Cr.	5508	2	0.20	3	0.30	1	0.17
Alexander Cr.	9500	1	0.10	2	0.13	3	0.23
Beaver Cr.	14000	2	0.07	1	0.03	3	0.50
Bogue Chitto	25000	1	0.23	3	0.27	1	0.23
Bogue Chitto	31500	3	0.40	1	0.27	2	0.33
Buckhorn Cr.	4150	1	0.20	1	0.20	3	0.23
Cypress Cr.	1500	2	0.23	3	0.30	1	0.17
Flagon Bayou	4730	1	0.27	2	0.30	2	0.30
Okatama Cr. near Magee	16100	1	0.17	2	0.20	3	0.23
Okatama Cr. East of Magee	12100	1	0.40	2	0.47	3	0.80
Pea Cr.	1780	1	0.37	1	0.37	3	0.50
Poley Cr.	1900	1	0.30	2	0.37	3	0.40
Poley Cr.	4600	1	0.20	2	0.23	3	0.50
Tenmile Cr.	6400	2	0.23	2	0.23	1	0.10
Thompson Cr.	3800	1	0.20	1	0.20	3	0.40
Yellow River	2000	1	0.17	1	0.17	3	0.23
Yellow River	6603	2	0.40	1	0.30	3	0.43
<b>Mean Average Absolute Error</b>			.24		.26		.33
<b>Total Number of No. 1 Rankings</b>		11		7		3	
<b>Total Number of No. 2 Rankings</b>		5		7		2	
<b>Total Number of No. 3 Rankings</b>		1		3		12	

the form of Hydrologic Atlases (USGS, 1978). Seventeen flood events were analyzed at 13 different bridge sites (four sites had two flood events). Hydraulic models of the bridge site, as well as several cross sections upstream and downstream, were developed using HEC-RAS, HEC-2, and WSPRO. Results were presented in tabular and graphical forms. Conclusions from this study are as follows:

1. In general, all models were able to compute water surface profiles within the tolerance of the observed data. The observed data at each cross section is based on a series of measured points as well as high water marks. The variation of the water surface at any given cross section was on the order of 0.1 to 0.3 feet. The observed water surface was taken as the mean value of the active flow area. The mean absolute error in computed versus observed water surface elevations varied from 0.24 (HEC-RAS) to 0.33 (WSPRO). Given the small variance in the results, it is believed that any of the models can be used to compute adequate water surface profiles at bridge locations, and that no one model performed significantly better than another.



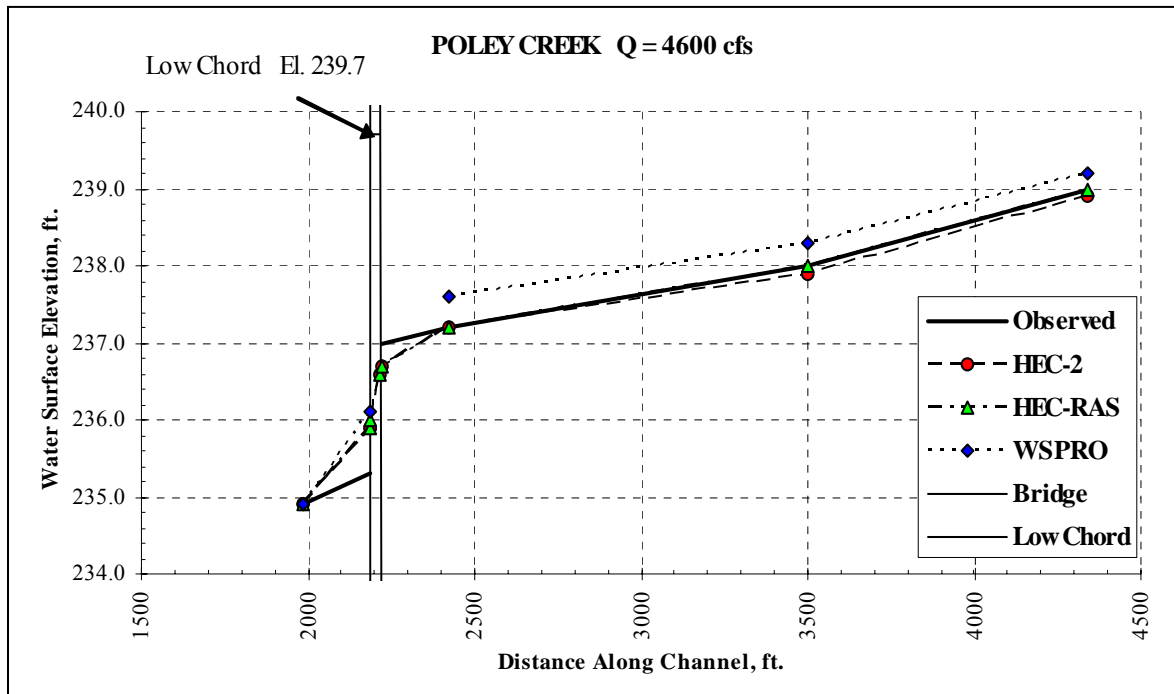

Figure 9. Computed and Observed Water Surface Profiles for Poley Creek

Table 3  
Computed and Observed Water Surface Elevation for Poley Creek

Cross Section Number	Channel distance (ft)	Obs. WSEL (ft)	HEC-RAS		HEC-2		WSPRO	
			WSEL (ft)	Error (ft)	WSEL (ft)	Error (ft)	WSEL (ft)	Error (ft)
4 EX	1985	234.9	234.9	0.0	234.9	0.0	234.9	0.0
4.1	2187	235.3	235.9	0.6	235.9	0.6	236.1	0.8
BR	2189	N/A	236.0		235.9		N/A	
BR	2217	N/A	236.6		236.6		N/A	
4.4	2219	237.0	236.7	-0.3	236.7	-0.3	N/A	
5 AP	2421	237.2	237.2	0.0	237.2	0.0	237.6	0.4
6	3501	238.0	238.0	0.0	237.9	-0.1	238.3	0.3
7	4341	239.0	239.0	0.0	238.9	-0.1	239.2	0.2

2. The HEC-RAS and HEC-2 energy based bridge solution methodologies are very similar to the WSPRO bridge procedure. All of the programs solve the water surface profile through the bridge by performing an energy balance. The following is a list of the differences between HEC-RAS, HEC-2, and WSPRO:

- By default HEC-RAS and HEC-2 use the average conveyance method for computing friction losses, while WSPRO uses the geometric mean method. All of the programs allow the user to select from four possible methods.
- HEC-RAS and HEC-2 compute expansion losses as a coefficient times the absolute change in velocity head from the section just downstream of the bridge to the exit section. WSPRO uses an expansion loss equation that was derived from an

approximate solution of the momentum, energy, and continuity equations. The derivation is based on a rectangular section expanding into a wider rectangular section.

- WSPRO uses the stream tube concept to compute a flow weighted reach length in the contraction reach, while both HEC-RAS and HEC-2 compute a flow weighted reach length based on the user entered left overbank, main channel, and right overbank reach lengths. These reach lengths are used in computing the friction losses in the contraction reach.
- Both HEC-RAS and HEC-2 compute a contraction loss upstream of the bridge as a contraction coefficient times the change in velocity head from the approach section to the section just upstream of the bridge. WSPRO does not compute a contraction loss in this reach, it is assumed to be zero.

3. The following factors have been found to be far more important than which model is used: accurate cross section information; the placement of cross sections in the vicinity of the bridge; Manning's n values; adequately modeling the bridge geometry; defining ineffective flow areas in the vicinity of the bridge; and the contraction and expansion coefficients.

4. Most of the large errors for all three models occurred adjacent to the downstream and upstream faces of the bridge. In most cases, all of the models did well in predicting the water surface at the approach section and further upstream. The errors in predicting water surface elevations adjacent to the bridge could be due to many factors. One factor may be an inadequate representation of the true active flow area in the vicinity of the bridge opening. Placing the ineffective flow area limits too far in, or too far away, from the edges of the bridge opening, can have a large impact on computing the water surface elevation. Another factor is that the flow may be highly multidimensional rather than one-dimensional, as being modeled by all three of these programs. Another possibility is that the downstream water surface may be controlled more by the bridge geometry than downstream conditions (i.e., model does not know about bridge geometry when computing downstream water surface). Also, the transition of the active flow area in the expansion reach is not a straight line between the downstream section and the exit section; this can have a large effect on the prediction of friction losses in the expansion reach, thus greatly affecting the computed water surface just downstream of the bridge.

5. The data for this study were all of a similar type, in that they all had wide and heavily vegetated floodplains. Manning's n values for the overbanks varied from 0.07 to 0.24. Velocities in the main channel were low, and the variation of velocity in the vicinity of the bridge was small. Because of these factors, the flow expansion transition was found to occur more rapidly and over a shorter distance than the traditional 4:1 expansion rate. Most of the data sets were found to expand at a rate of 1 times the average obstruction length of the bridge roadway embankment. A few of the data sets required a longer expansion reach. The use of a 4:1 expansion ratio would have resulted in over predicting the water surface elevations in the vicinity of the bridge. In general, placing cross sections too far apart in the expansion reach will cause an over prediction in the friction losses, thus causing the over prediction of the water surface elevations. The program uses an average friction slope times a weighted reach length to compute the friction losses. When the cross sections are too far apart, the averaging normally

ends up in over predicting the friction losses. In the case of the bridge expansion reach, the friction slope (slope of the energy grade line) just downstream of the bridge is very steep. The flow will normally expand very rapidly at first, and then the expansion rate will decrease. This causes the greatest changes in the friction slope to occur near the bridge. Because the transition of flow and change in the friction slope are not linear, none of the friction slope averaging techniques can adequately model the friction losses over a long reach. Thus the placement of the exit cross section is very important in modeling the friction losses that occur in the expansion reach. Given that a limited number of data sets were used in this study, and that they all had several similar characteristics, generalizations about the appropriate expansion ratio, for all cases, could not be drawn.

6. At most of the bridge sites the contraction and expansion coefficients did not play an important role in the calibration and modeling of the water surface profiles for these bridge sites. Because the change in velocities in and around the bridges was small, the magnitude of contraction and expansion losses were generally small compared to the friction losses. At a few of the bridge sites, the contraction and expansion losses were significant in comparison to the friction losses. At all of these sites, traditional values of 0.3 and 0.5 were used for the contraction and expansion coefficients respectively. These coefficients were not used as a calibration parameter for this study. However, in many studies these coefficients could play a much greater role in predicting the energy losses and water surface elevations in the vicinity of the bridge.



## Appendix A

### References

- Bradley, J.N., 1978. *Hydraulics of Bridge Waterways*, Hydraulic Design Series No. 1, Federal Highway Administration, U.S. Department of Transportation, Second Edition, revised March 1978, Washington D.C.
- Eichert, B.S. and J.C. Peters, 1970. *Computer Determination of Flow Through Bridges*, Hydrologic Engineering Center, Technical Paper 20, U.S. Army Corps of Engineers, Davis, CA.
- FHWA, 1990. User's Manual for WSPRO - A computer model for water surface profile computations, Federal Highway Administration, Publication No. FHWA-IP-89-027, 177 p.
- Hydrologic Engineering Center, 1991. *HEC-2, Water Surface Profiles*, User's Manual, U.S. Army Corps of Engineers, Davis CA.
- Hydrologic Engineering Center, 1995. *HEC-RAS, River Analysis System*, User's Manual, U.S. Army Corps of Engineers, Davis CA.
- Hydrologic Engineering Center, 1995. *HEC-RAS, River Analysis System*, Hydraulic Reference Manual, U.S. Army Corps of Engineers, Davis CA.
- Koch-Carstanjen, 1962. Von de Bewegung des Wassers and Den Dabei Auftretenden Kraten, Hydrofynamim, Berlin. A partial translation appears in Appendix 1, "Report on Engineering Aspects of the Flood of March 1938," U.S. Army Engineering District, Los Angeles, May 1939.
- U.S. Army Corps of Engineers, 1963. *Hydraulic Design of Reservoir Outlet Structures*, EM 1110-2 1602, Washington D.C.
- USGS, 1953. *Computation of Peak Discharge at Contractions*, Kindsvater, C.E., R.W. Carter, and H. J. Tracy, U.S. Geological Survey Circular 284, Washington, D.C., 35 pp.
- USGS, 1978. *Hydrologic Investigation Atlases HA 591 - HA 611*, Department of the Interior, Denver, CO.
- Yarnell, D.L., 1934. "Bridge Piers as Channel Obstructions," Technical Bulletin 442, U.S. Department of Agriculture, Washington D.C.



## **Appendix B**

### **Model Comparison Results for: HEC-RAS, HEC-2, and WSPRO**

This Appendix contains detailed tables and graphics for all of the bridge sites and flood events used in this study. Part 1 of this appendix contains the results from HEC-RAS (Energy Method), HEC-2 (Normal Bridge Method), and WSPRO.

Part 2 of this appendix includes comparison tables and graphics for three events in which the observed water surface elevations were above the bridge low chords. This portion of the appendix was used to compare the alternative bridge modeling methods in HEC-RAS and HEC-2 for high flows. This section contains results for the HEC-RAS energy method, HEC-RAS pressure and weir flow, HEC-2 Normal Bridge, and HEC-2 Special Bridge. The comparisons of high flows show no significant differences between the four methods for the three events that were analyzed. However, three data sets are far too few to make any judgments about the modeling methods for high flows.





ALEXANDER CREEK, LOUISIANA Q = 5508 cfs

	Computed Results From:													
	HEC-2						HEC-RAS						WSPRO	
	Channel Distance, ft	Section Minimum Elevation, ft	Observed WSEL, ft	Depth, ft	WSEL, ft	Absolute Error, ft	Relative Error Squared ***	WSEL, ft	Absolute Error, ft	Relative Error Squared ***	WSEL, ft	Absolute Error, ft	Relative Error Squared ***	
5 EX	2675	74.2	86.9	12.7	86.9	0.0	7.58E-04	86.9	0.0	3.37E-04	86.9	0.0	7.58E-04	
5.1	2915	76.8	87.7	10.9	87.4	-0.3	7.58E-04	87.5	-0.2	3.37E-04	87.4	-0.3	7.58E-04	
BR	2917	76.8	NA		87.4			87.5			NA			
BR	2943	76.8	NA		87.5			87.6			NA			
5.4	2945	76.8	88.5*	11.7	87.6	-0.9	9.59E-04	87.7	-0.8	4.26E-04	NA		1.07E-04	
6 AP	3205	78.7	88.4	9.7	88.1	-0.3	9.97E-04	88.2	-0.2	4.43E-04	88.3	-0.1	1.11E-04	
7	3690	79.3	88.8	9.5	88.5	-0.3	9.97E-04	88.6	-0.2	4.43E-04	88.7	-0.1	1.11E-04	
8	4550	80.4	89.3	8.9	89.4	0.1		89.5	0.2		89.5	0.2		
9	5820	81.9	91.1	9.2	91.0	-0.1		91.1	0.0		91.0	-0.1		
10	6670	83.1	91.9	8.8	92.2	0.3		92.2	0.3		92.2	0.3		

Sum of Rel. Error Squared: 0.0027

0.0012

0.0010

Standard Error\*\*\*: 0.030

0.020

0.018

**EXPLANATION OF SYMBOLS:**

- EX Denotes the section downstream of the bridge where effective flow width is assumed to have expanded to the full floodplain width. In this study the distance to full expansion is assumed to be approximately equal to the transverse width of the bridge opening, unless otherwise noted.
- BR Denotes a section just inside the bridge.
- AP Denotes the section located upstream of the bridge a distance approximately equal to the transverse width of the bridge opening.
- NA Indicates that the value is not available from the data or the program output.
- \* Indicates that the observed water surface value is questionable either because there were very few values recorded on the atlas and/or because those that have been provided are not located within the active flow area
- \*\* Relative Error Squared is equal to the square of the absolute error divided by the depth:  $(\text{Abs. Error} / \text{Depth})^2$ .
- \*\*\* Standard Error is equal to the square root of the Relative Error Squared divided by the number of RES values summed:  $(\text{Rel. Error Sq} / n)^{0.5}$

ALEXANDER CREEK Q = 5508 cfs

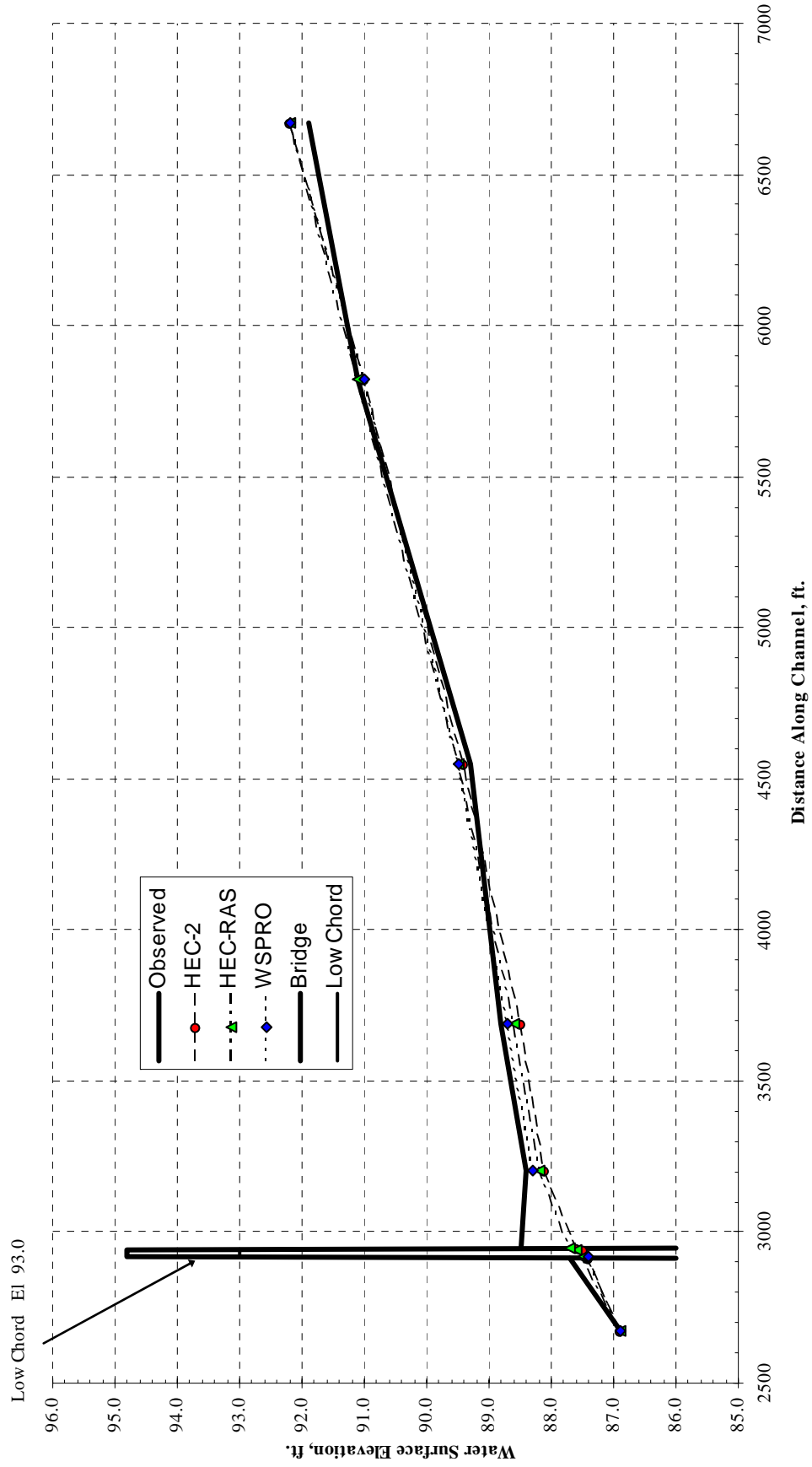

ALEXANDER CREEK, LOUISIANA Q = 9500 cfs

Computed Results From:														
HEC-2						HEC-RAS						WSPRO		
Channel Distance, ft	Section Minimum Elevation, ft	Observed WSEL, ft	Depth, ft	WSEL, ft	Absolute Error, ft	Relative Error Squared **	WSEL, ft	Absolute Error, ft	Relative Error Squared ***	WSEL, ft	Absolute Error, ft	Relative Error Squared ***		
5 EX	2675	88.4	14.2	88.4	0.0	2.64E-04	88.4	0.0	6.61E-05	88.4	0.0	1.65E-03		
5.1	2915	89.1	12.3	88.9	-0.2	2.64E-04	89.0	-0.1	6.61E-05	88.6	-0.5	1.65E-03		
BR	2917	NA		88.8			88.9			NA				
BR	2943	NA		89.0			89.1			NA				
5.4	2945	90.0	13.2	89.3	-0.7	3.03E-04	89.4	-0.6	7.57E-05	90.1	-0.1	7.57E-05		
6 AP	3205	90.2	11.5	90.0	-0.2	3.03E-04	90.1	-0.1	7.57E-05	90.4	0.1	8.26E-05		
7	3690	90.3	11.0	90.3	0.0	0.00E+00	90.4	0.1	8.26E-05	90.4	0.1	8.26E-05		
8	4550	90.9	10.5	91.0	0.1	0.00E+00	91.2	0.3	0.3	91.2	0.3	0.3		
9	5820	92.4	10.5	92.4	0.0	0.0	92.5	0.1	0.1	92.4	0.0	0.0		
10	6670	92.9	9.8	93.5	0.6	0.0006	93.6	0.7	0.0002	93.5	0.6	0.0018		

Sum of Rel. Error Squared: 0.0006

Standard Error\*\*\*: 0.014

0.0002

0.009

0.0018

0.025

**EXPLANATION OF SYMBOLS:**

- EX Denotes the section downstream of the bridge where effective flow width is assumed to have expanded to the full floodplain width. In this study the distance to full expansion is assumed to be approximately equal to the transverse width of the bridge opening, unless otherwise noted.
- BR Denotes a section just inside the bridge.
- AP Denotes the section located upstream of the bridge a distance approximately equal to the transverse width of the bridge opening.
- NA Indicates that the value is not available from the data or the program output.
- \* Indicates that the observed water surface value is questionable either because there were very few values recorded on the atlas and/or because those that have been provided are not located within the active flow area
- \*\*\* Relative Error Squared is equal to the square of the absolute error divided by the depth: (Abs. Error / Depth )^2.
- \*\*\*\* Standard Error is equal to the square root of the Relative Error Squared divided by the number of RES values summed: (Rel. Error Sq / n)^0.5

ALEXANDER CREEK Q = 9500 cfs

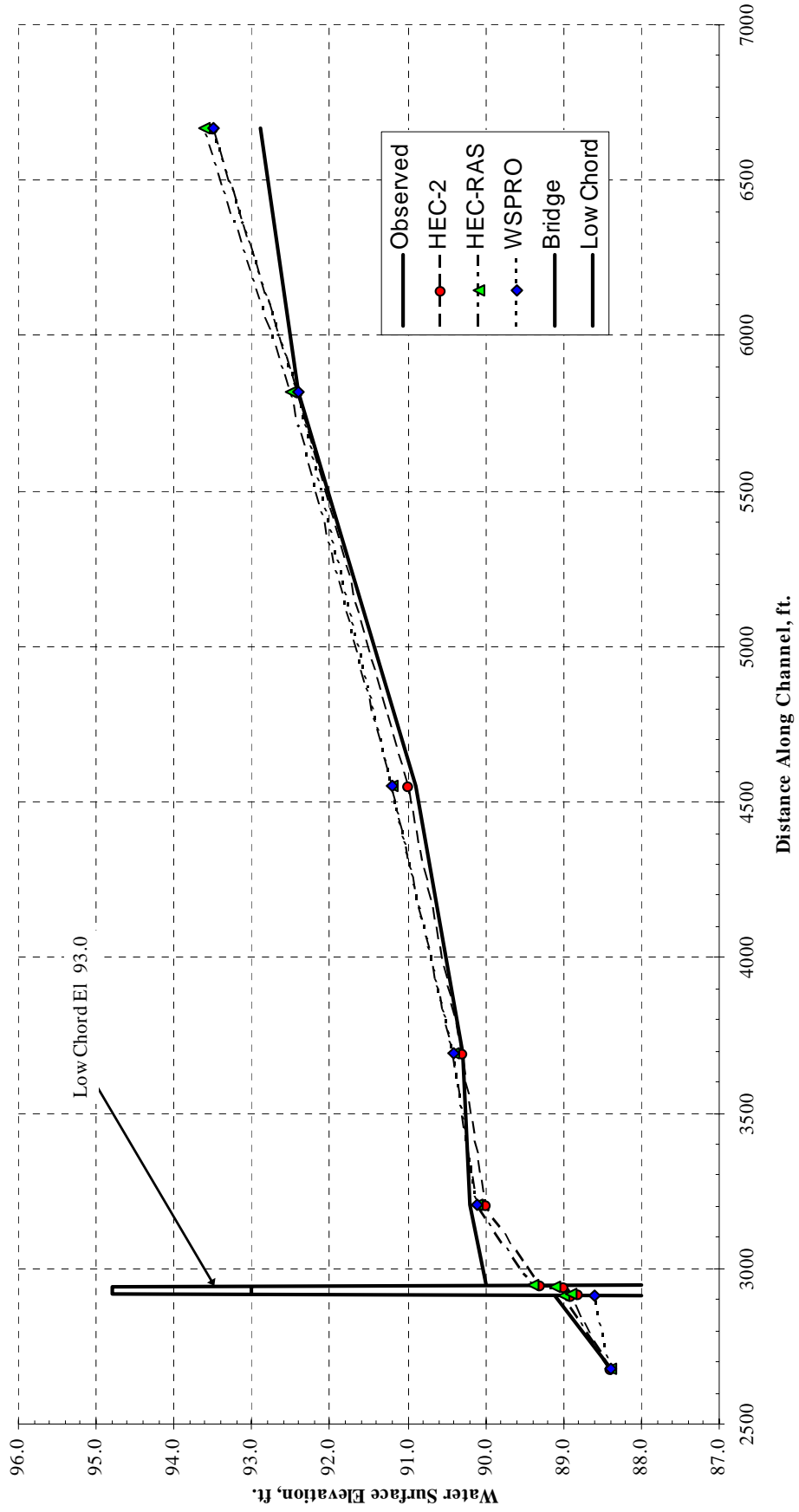

BEAVER CREEK, LOUISIANA Q = 14000 cfs

	Computed Results From:														
	HEC-2 (special bridge)				HEC-RAS (pressure + weir)				WSPRO						
	Channel Distance, ft	Section Minimum Elevation, ft	Observed WSEL, ft	Depth, ft	WSEL, ft	Absolute Error, ft	Relative Error Squared ***	WSEL, ft	Absolute Error, ft	Relative Error Squared ***	WSEL, ft	Absolute Error, ft	Relative Error Squared ***		
3 EX	820	202.8	214.9	12.1	214.9	0.0	0.00E+00	214.9	0.0	0.0	214.9	0.0	1.57E-03		
4.1	1312	202.6	215.2	12.6	215.2	0.0	0.00E+00	215.3	0.1	6.30E-05	215.7	0.5			
BR	1313	202.7	NA		NA			215.5			NA				
BR	1339	202.7	NA		NA			216.6			NA				
4.4	1340	202.6	217.8*	15.2	215.9	-1.9	0.00E+00	216.5	-1.3		217.2	-0.6			
5 AP	1540	203.9	217.8	13.9	217.8	0.0	0.00E+00	217.9	0.1	5.18E-05	217.3	-0.5	1.29E-03		
6	2404	200.0	218.1	18.1	218.0	-0.1	3.05E-05	218.1	0.0	0.00E+00	217.6	-0.5	7.63E-04		
7	3224	205.0	218.4	13.4	218.4	0.0		218.6	0.2		218.1	-0.3			
				Sum of Rel. Error Squared:				0.0000				0.0001			
				Standard Error****:				0.003				0.006			
												0.0036			
												0.035			

**NOTE:** At this site, the observed water surface was over the top of the bridge deck. The value for WSPRO at ref. dist. 1340 represents the computed water surface over the road. The HEC-2 and HEC-RAS models shown here incorporate energy-only computation methods.

**EXPLANATION OF SYMBOLS:**

- EX Denotes the section downstream of the bridge where effective flow width is assumed to have expanded to the full floodplain width. In this study the straight line distance to full expansion is assumed to be approximately equal to the transverse width of the bridge opening, unless otherwise noted.
- BR Denotes a section just inside the bridge.
- AP Denotes the section located upstream of the bridge a distance approximately equal to the transverse width of the bridge opening.
- NA Indicates that the value is not available from the data or the program output.
- \* Indicates that the observed water surface value is questionable either because there were very few values recorded on the atlas and/or because those that have been provided are not located within the active flow area
- \*\* Relative Error Squared is equal to the square of the absolute error divided by the depth: (Abs. Error / Depth )<sup>2</sup>.
- \*\*\* Standard Error is equal to the square root of the Relative Error Squared divided by the number of RES values summed: (Rel. Error Sq / n)<sup>0.5</sup>

**BEAVER CREEK Q = 14000 cfs**

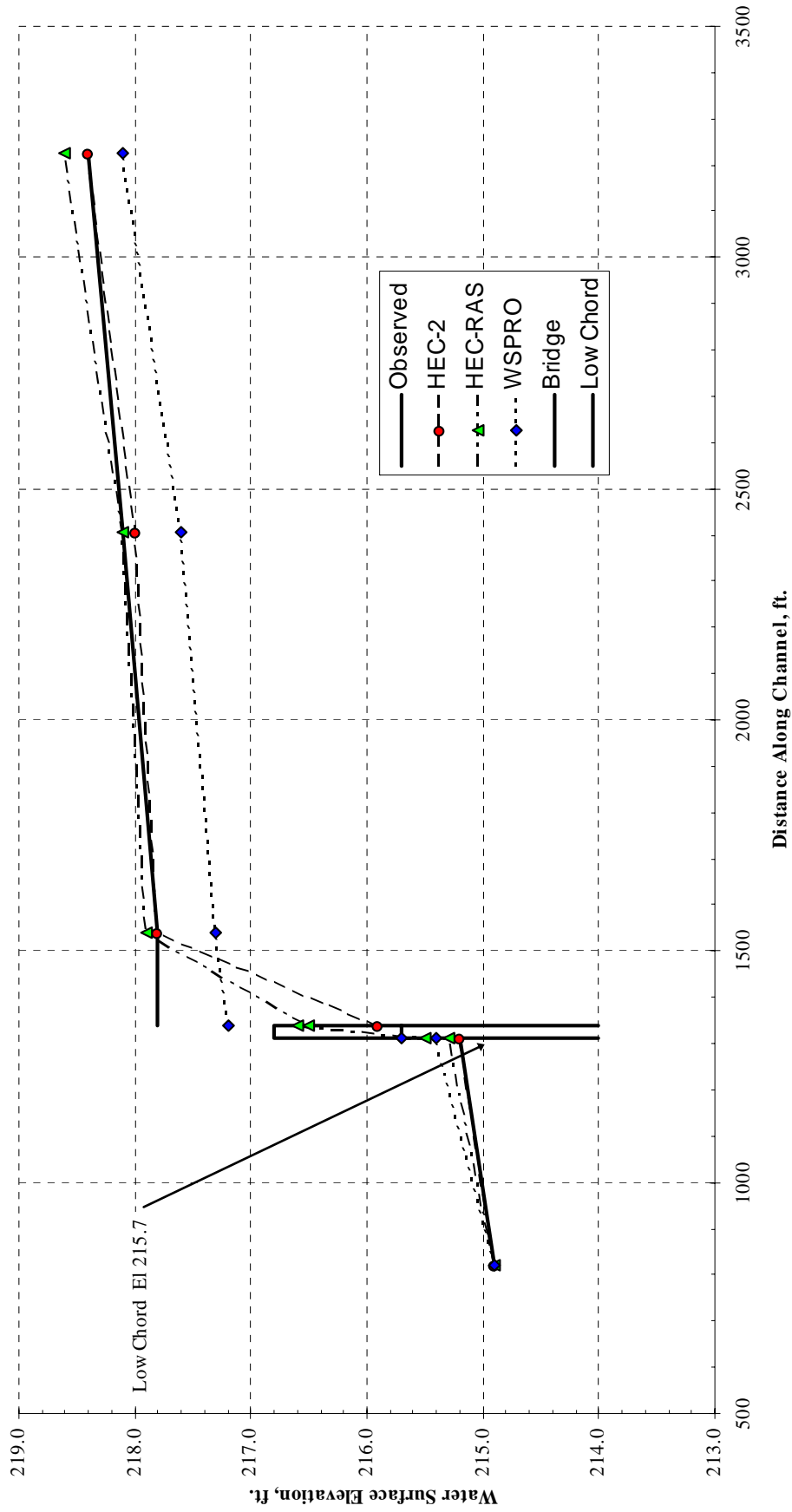

**BOGUE CHITTO, MISSISSIPPI Q = 25000 cfs**

	Computed Results From:													
	HEC-2						HEC-RAS						WSPRO	
	Channel Distance, ft	Section Minimum Elevation, ft	Observed WSEL, ft	Depth, ft	WSEL, ft	Absolute Error, ft	Relative Error Squared ***	WSEL, ft	Absolute Error, ft	Relative Error Squared ***	WSEL, ft	Absolute Error, ft	Relative Error Squared ***	
4 EX	11280	315.9	335.2	19.3	335.2	0.0	6.66E-05	335.2	0.0	1.67E-05	335.2	0.0	6.66E-05	
4.4	11706	311.2	335.7	24.5	335.5	-0.2	6.66E-05	335.6	-0.1	1.67E-05	335.9	0.2	6.66E-05	
BR	11707	311.2	NA		335.5			335.6			NA			
BR	11738	311.2	NA		335.9			336.1			NA			
4.7	11739	311.2	336.0	24.8	335.9	-0.1		NA			NA			
5 AP	12165	315.2	337.3	22.1	337.5	0.2	8.19E-05	337.8	0.5	5.12E-04	337.6	0.3	1.84E-04	
6	13295	314.0	338.2	24.2	337.8	-0.4	2.73E-04	338.1	-0.1	1.71E-05	338.0	-0.2	6.83E-05	
7	20095	319.7	340.4	20.7	340.2	-0.2		340.4	0.0		340.4	0.0		
8	27695	324.4	343.3	18.9	344.0	0.7		344.1	0.8		344.0	0.7		
9	35995	329.9	348.2	18.3	348.2	0.0		348.3	0.1		348.2	0.0		

Sum of Rel. Error Squared: 0.0004

Standard Error\*\*\*: 0.012

0.0005

0.013

0.0003

0.010

**EXPLANATION OF SYMBOLS:**

- EX Denotes the section downstream of the bridge where effective flow width is assumed to have expanded to the full floodplain width. In this study the distance to full expansion is assumed to be approximately equal to the transverse width of the bridge opening, unless otherwise noted.
- BR Denotes a section just inside the bridge.
- AP Denotes the section located upstream of the bridge a distance approximately equal to the transverse width of the bridge opening.
- NA Indicates that the value is not available from the data or the program output.
- \* Indicates that the observed water surface value is questionable either because there were very few values recorded on the atlas and/or because those that have been provided are not located within the active flow area
- \*\*\* Relative Error Squared is equal to the square of the absolute error divided by the depth: (Abs. Error / Depth )<sup>2</sup>.
- \*\*\*\* Standard Error is equal to the square root of the Relative Error Squared divided by the number of RES values summed: (Rel. Error Sq / n)<sup>0.5</sup>

**BOGUECHITTO Q = 25000 cfs**

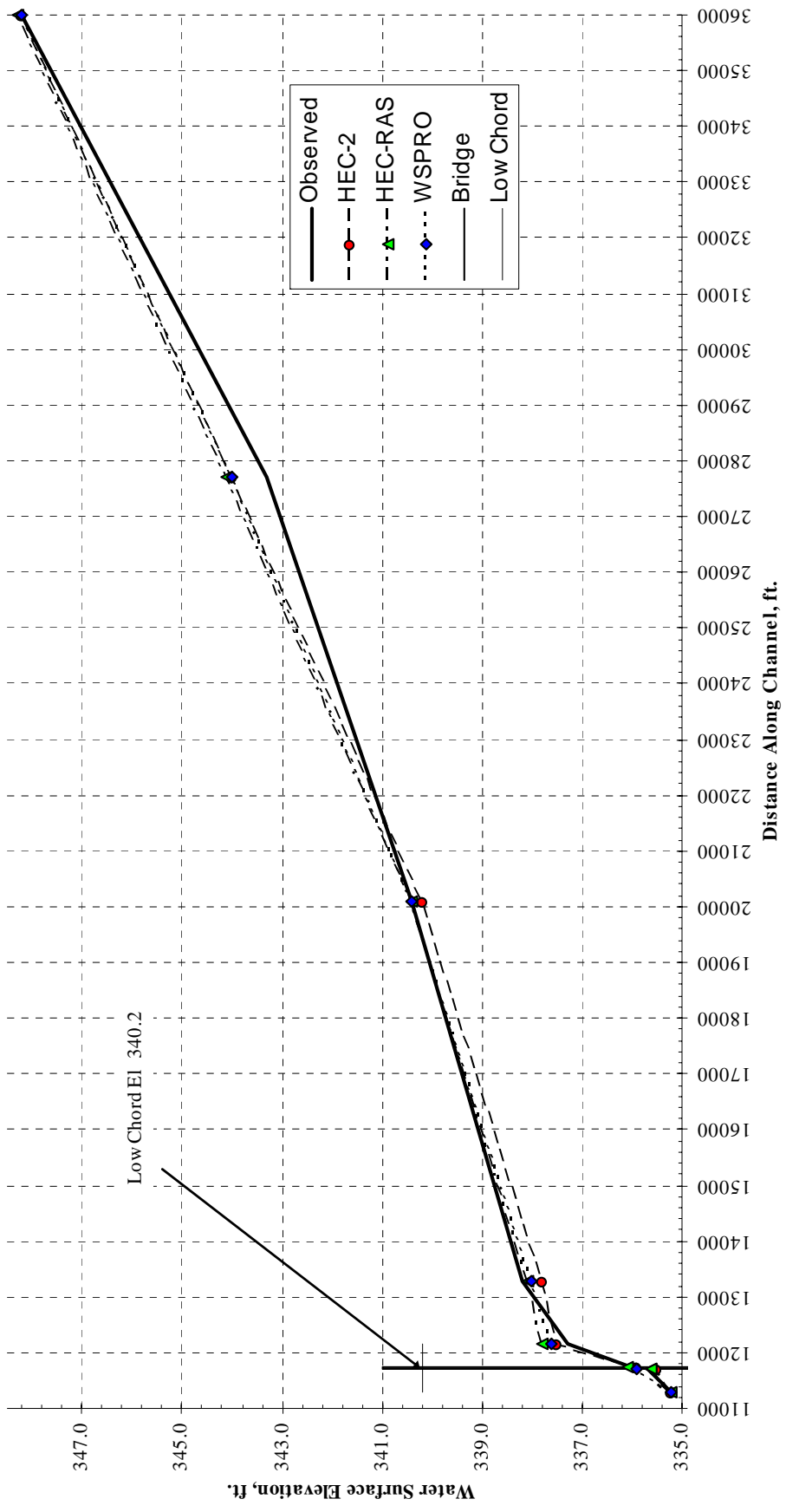



**BOGUE CHITTO, MISSISSIPPI Q = 31500 cfs**

Computed Results From:														
HEC-2						HEC-RAS						WSPRO		
Channel Distance, ft	Section Minimum Elevation, ft	Observed WSEL, ft	Depth, ft	WSEL, ft	Absolute Error, ft	Relative Error Squared ***	WSEL, ft	Absolute Error, ft	Relative Error Squared ***	WSEL, ft	Absolute Error, ft	Relative Error Squared ***		
4 EX	11280	335.6	19.7	335.6	0.0	5.81E-04	335.6	0.0	1.45E-04	335.6	0.0	6.45E-05		
4.4	11706	336.1*	24.9	335.5	-0.6	5.81E-04	335.8	-0.3	1.45E-04	336.3	0.2	6.45E-05		
BR	11707	NA		335.5			335.8			NA				
BR	11738	NA		336.1			336.4			NA				
4.7	11739	337.7*	26.5	336.2	-1.5		NA			NA				
5 AP	12165	NA		338.2			338.6			338.5				
6	13295	338.3	24.3	338.5	0.2	6.77E-05	338.9	0.6	6.10E-04	338.8	0.5	4.23E-04		
7	20095	340.6	20.9	340.6	0.0		340.9	0.3		340.9	0.3			
8	27695	343.3	18.9	344.2	0.9		344.3	1.0		344.3	1.0			
9	35995	348.2	18.3	348.4	0.2		348.5	0.3		348.5	0.3			
Sum of Rel. Error Squared:						0.0006	0.0008						0.0005	
Standard Error***:						0.015	0.016						0.013	

**EXPLANATION OF SYMBOLS:**

- EX Denotes the section downstream of the bridge where effective flow width is assumed to have expanded to the full floodplain width. In this study the distance to full expansion is assumed to be approximately equal to the transverse width of the bridge opening, unless otherwise noted.
- BR Denotes a section just inside the bridge.
- AP Denotes the section located upstream of the bridge a distance approximately equal to the transverse width of the bridge opening.
- NA Indicates that the value is not available from the data or the program output.
- \* Indicates that the observed water surface value is questionable either because there were very few values recorded on the atlas and/or because those that have been provided are not located within the active flow area
- \*\*\* Relative Error Squared is equal to the square of the absolute error divided by the depth: (Abs. Error / Depth )<sup>2</sup>.
- \*\*\*\* Standard Error is equal to the square root of the Relative Error Squared divided by the number of RES values summed: (Rel. Error Sq / n)<sup>0.5</sup>

BOGUE CHITTO Q = 31500 cfs

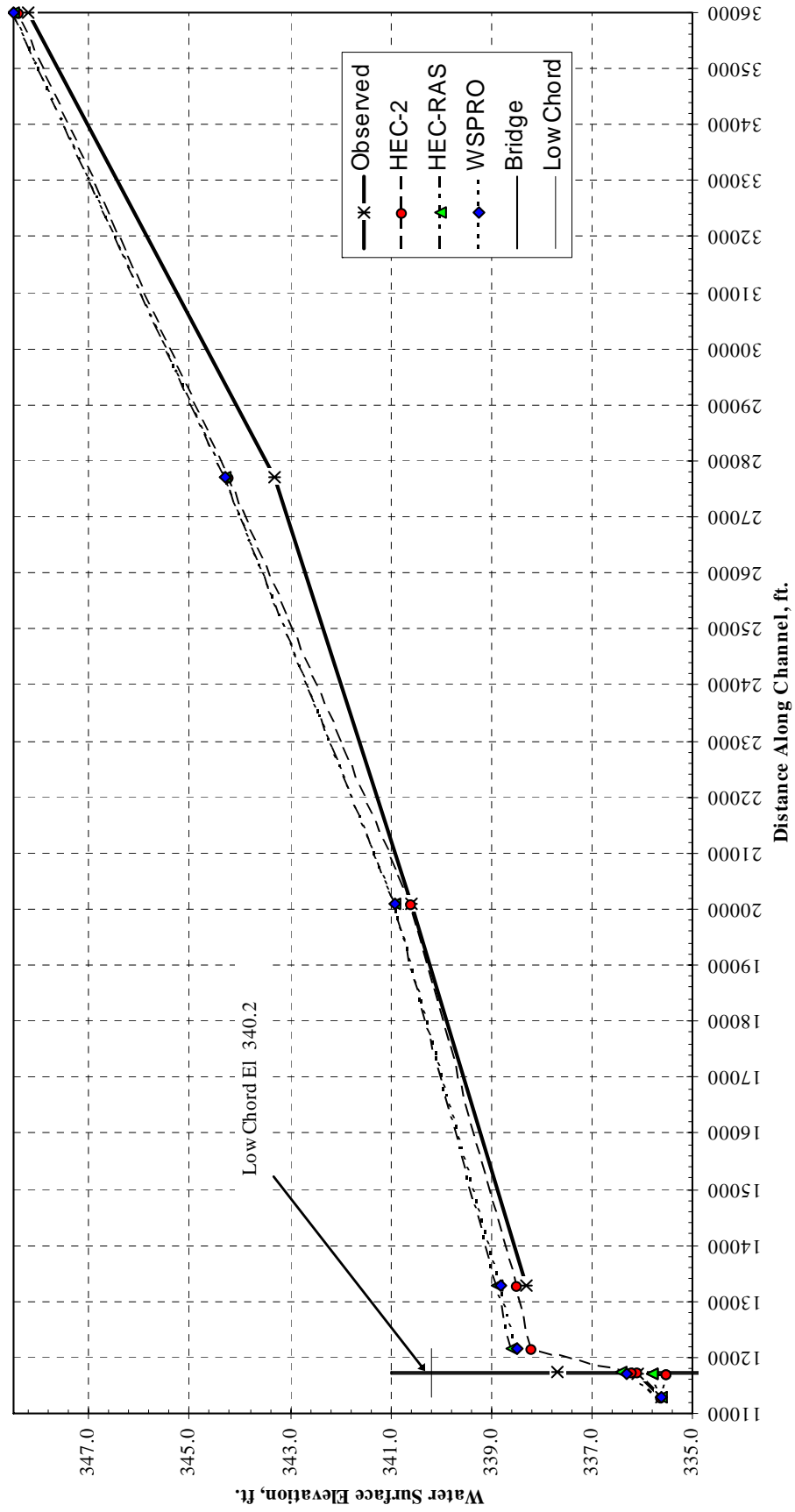

FLAGON BAYOU, LOUISIANA Q = 4730 cfs

	Computed Results From:													
	HEC-2						HEC-RAS						WSPRO	
	Channel Distance, ft	Section Minimum Elevation, ft	Observed WSEL, ft	Depth, ft	WSEL, ft	Absolute Error, ft	Relative Error Squared ***	WSEL, ft	Absolute Error, ft	Relative Error Squared ***	WSEL, ft	Absolute Error, ft	Relative Error Squared ***	
5 EX1	11826	59.5	75.8	16.3	75.8	0.0	1.01E-04	75.8	0.0	0.0	NA	NA	2.53E-05	
5 EX	11938	59.5	75.9	16.4	NA	NA	1.01E-04	NA	NA	NA	75.9	0.0	0.0	
6.1	12138	56.2	76.1*	19.9	75.9	-0.2	1.01E-04	75.9	-0.2	1.01E-04	76.2	0.1	2.53E-05	
BR	12140	56.2	NA	NA	75.9	NA	1.01E-04	75.9	NA	NA	NA	NA	2.53E-05	
BR	12173	56.2	NA	NA	76.0	NA	1.01E-04	76.0	NA	NA	NA	NA	2.53E-05	
6.4	12175	56.2	76.2*	20.0	76.0	-0.2	1.01E-04	76.0	-0.2	1.01E-04	76.2	0.1	2.53E-05	
7 AP	12375	66.2	76.3	10.1	76.2	-0.1	9.80E-05	76.2	-0.1	9.80E-05	76.9	0.6	3.53E-03	
8	13983	67.3	77.6	10.3	77.0	-0.6	3.39E-03	77.1	-0.5	2.36E-03	77.4	-0.2	3.77E-04	
9	17100	62.9	79.7	16.8	79.4	-0.3	0.0036	79.6	-0.1	0.0026	79.6	-0.1	0.0039	
						Sum of Rel. Error Squared:						0.0036		
						Standard Error***:						0.029		

**EXPLANATION OF SYMBOLS:**

- EX Denotes the section downstream of the bridge where effective flow width is assumed to have expanded to the full floodplain width. In this study the distance to full expansion is assumed to be approximately equal to the transverse width of the bridge opening, unless otherwise noted.
- EX1 Denotes a section approx.0.5 times the average bridge constriction width downstream from the bridge. This is considered the full expansion section for the HEC-2 and HEC-RAS runs at this site
- BR Denotes a section just inside the bridge.
- AP Denotes the section located upstream of the bridge a distance approximately equal to the transverse width of the bridge opening.
- NA Indicates that the value is not available from the data or the program output.
- \* Indicates that the observed water surface value is questionable either because there were very few values recorded on the atlas and/or because those that have been provided are not located within the active flow area
- \*\*\* Relative Error Squared is equal to the square of the absolute error divided by the depth: (Abs. Error / Depth )^2.
- \*\*\*\* Standard Error is equal to the square root of the Relative Error Squared divided by the number of RES values summed: (Rel. Error Sq / n)^0.5

FLAGON BAYOU Q = 4730 cfs

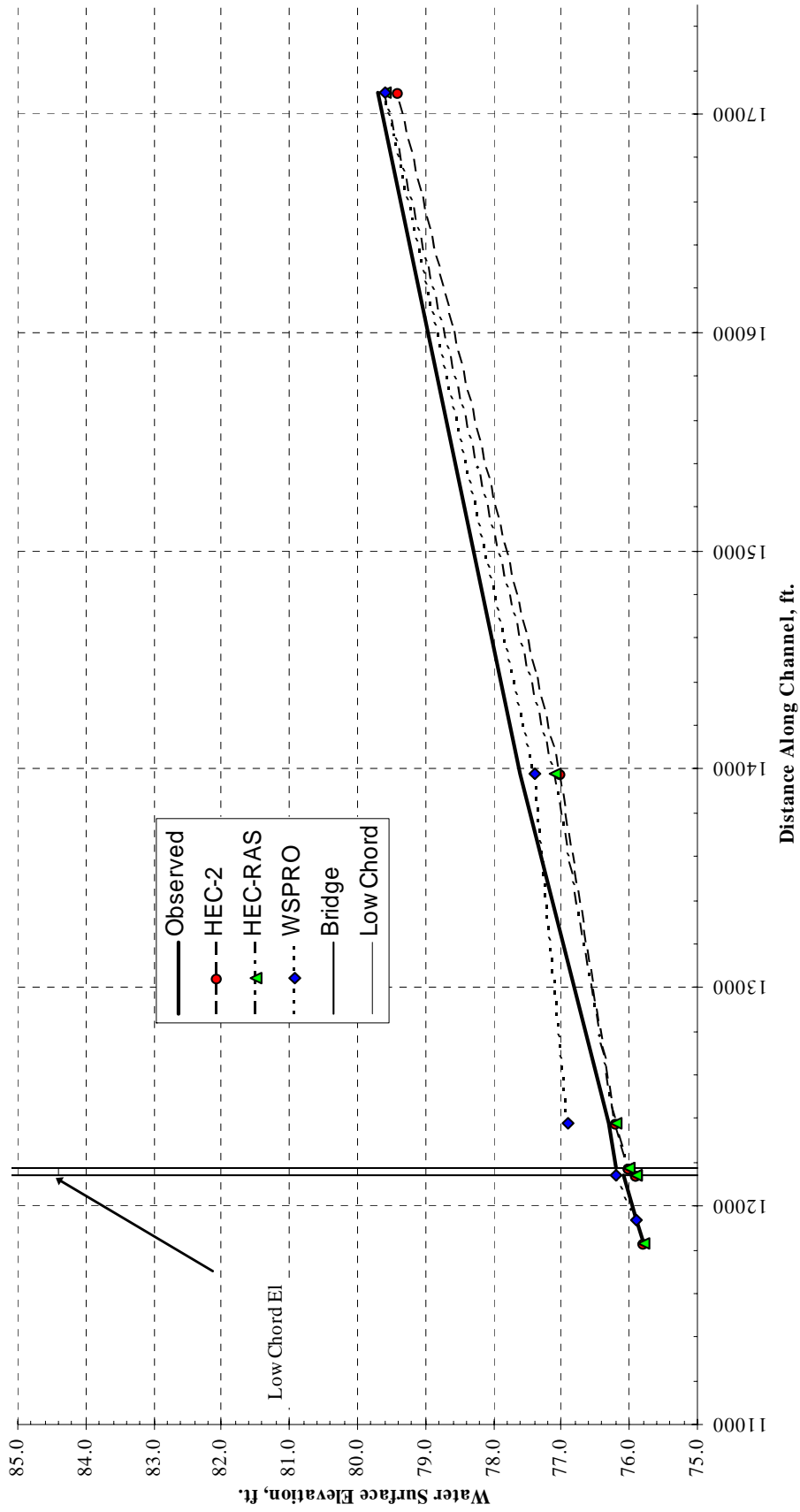

CYPRESS CREEK, LOUISIANA Q = 1500 cfs

Computed Results From:														
HEC-2						HEC-RAS						WSPRO		
Channel Distance, ft	Section Minimum Elevation, ft	Observed WSEL, ft	Depth, ft	WSEL, ft	Absolute Error, ft	Relative Error Squared **	WSEL, ft	Absolute Error, ft	Relative Error Squared **	WSEL, ft	Absolute Error, ft	Relative Error Squared **		
4 EX	2275	114.7	7.9	114.7	0.0	1.28E-03	114.7	0.0	1.28E-03	114.7	0.0	1.28E-03		
4.4	2390	114.8*	5.6	115.0	0.2	1.28E-03	115.0	0.2	1.28E-03	115.0	0.2	1.28E-03		
BR	2392	NA		115.0			115.0			NA				
BR	2428	NA		115.3			115.4			NA				
4.4	2430	116.0*	7.6	115.4	-0.6		115.4	-0.6		NA				
5 AP	2540	116.1	7.7	115.7	-0.4	2.70E-03	115.8	-0.3	1.52E-03	115.9	-0.2	6.75E-04		
6	2890	116.2	7.1	115.9	-0.3	1.79E-03	116.0	-0.2	7.93E-04	116.1	-0.1	1.98E-04		
7	3520	116.7	5.2	116.4	-0.3	3.33E-03	116.5	-0.2	1.48E-03	116.7	0.0	0.00E+00		
8	4120	117.2	5.6	117.2	0.0		117.3	0.1		117.5	0.3			
9	4660	119.0	8.7	118.6	-0.4		118.6	-0.4		119.1	0.1			
Sum of Rel. Error Squared:						0.0091	0.00518						0.0021	
Standard Error***:						0.048	0.036						0.023	

**EXPLANATION OF SYMBOLS:**

- EX Denotes the section downstream of the bridge where effective flow width is assumed to have expanded to the full floodplain width. In this study the distance to full expansion is assumed to be approximately equal to the transverse width of the bridge opening, unless otherwise noted.
- BR Denotes a section just inside the bridge.
- AP Denotes the section located upstream of the bridge a distance approximately equal to the transverse width of the bridge opening.
- NA Indicates that the value is not available from the data or the program output.
- \* Indicates that the observed water surface value is questionable either because there were very few values recorded on the atlas and/or because those that have been provided are not located within the active flow area
- \*\* Relative Error Squared is equal to the square of the absolute error divided by the depth: (Abs. Error / Depth )^2.
- \*\*\* Standard Error is equal to the square root of the Relative Error Squared divided by the number of RES values summed: (Rel. Error Sq / n)^0.5

CYPRESS CREEK Q = 1500 cfs

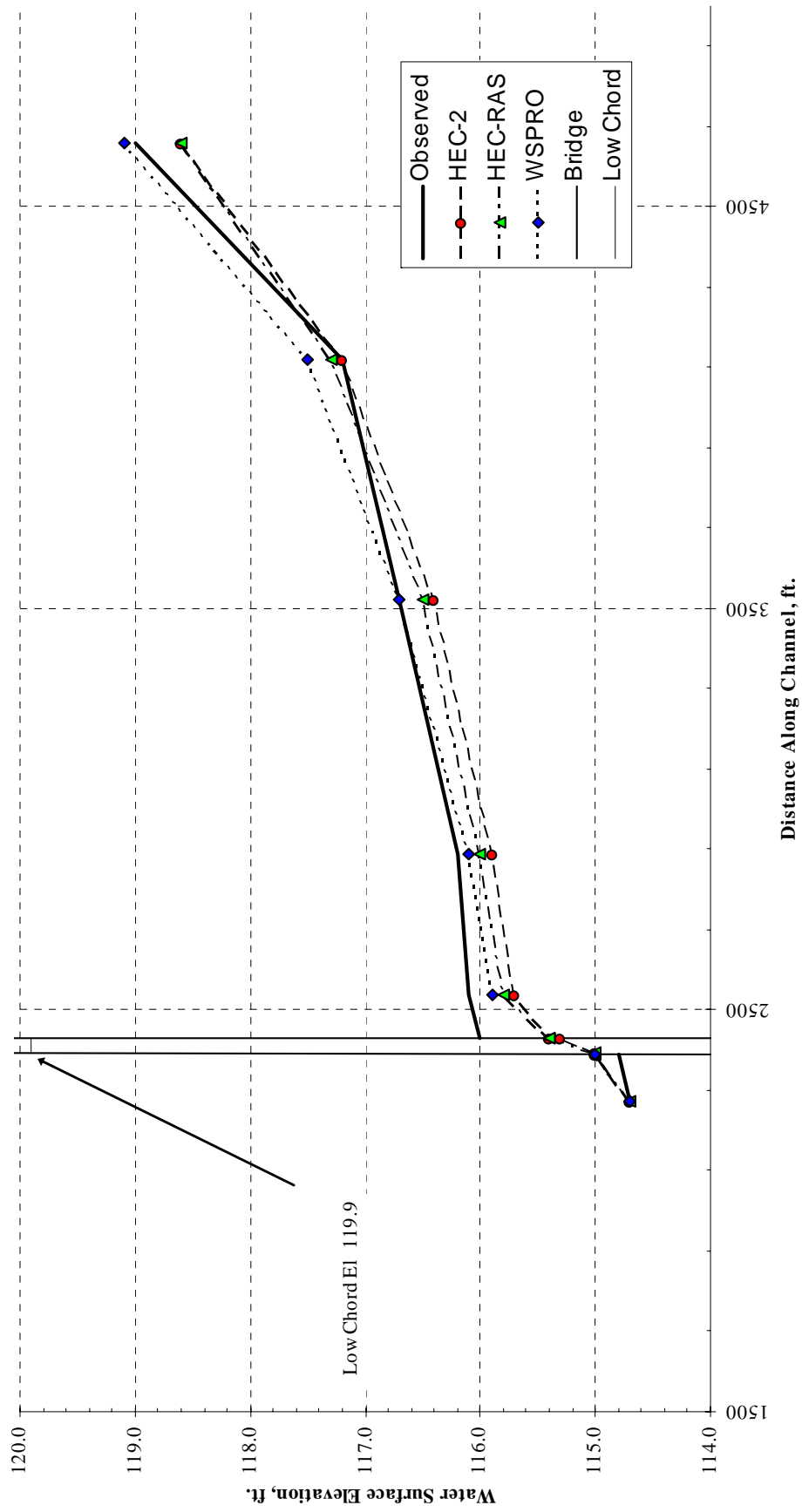

BUCKHORN CREEK, ALABAMA Q = 4150 cfs

Computed Results From:												
HEC-2						HEC-RAS			WSPRO			
Channel Distance, ft	Section Minimum Elevation, ft	Observed WSEL, ft	Depth, ft	WSEL, ft	Absolute Error, ft	Relative Error Squared ***	WSEL, ft	Absolute Error, ft	Relative Error Squared ***	WSEL, ft	Absolute Error, ft	Relative Error Squared ***
5 EX	3444	320.6	9.7	320.6	0.0	9.18E-04	320.6	0.0	9.18E-04	320.6	0.0	1.63E-03
5.1	3700	320.8	9.9	321.1	0.3	9.18E-04	321.1	0.3	9.18E-04	321.2	0.4	1.63E-03
BR	3702	NA		321.1			321.1			NA		
BR	3730	NA		321.5			321.6			NA		
5.4	3732	321.6	10.7	321.6	0.0	0.00E+00	321.6	0.0	1.13E-04	322.3	0.3	1.02E-03
6 AP	3988	322.0	9.4	322.0	0.0	0.00E+00	322.1	0.1	4.16E-04	323.1	0.0	0.00E+00
7	4973	323.1*	9.8	322.8	-0.3	9.37E-04	322.9	-0.2	4.16E-04	324.0	-0.1	
8	6220	324.1*	8.7	323.7	-0.4		323.8	-0.3		324.8	0.2	
9	7380	324.6*	5.1	324.6	0.0		324.6	0.0				
Sum of Rel. Error Squared:						0.0019	0.0014			0.0027		
Standard Error***:						0.025	0.022			0.030		

EXPLANATION OF SYMBOLS:

- EX Denotes the section downstream of the bridge where effective flow width is assumed to have expanded to the full floodplain width. In this study the distance to full expansion is assumed to be approximately equal to the transverse width of the bridge opening, unless otherwise noted.
- BR Denotes a section just inside the bridge.
- AP Denotes the section located upstream of the bridge a distance approximately equal to the transverse width of the bridge opening.
- NA Indicates that the value is not available from the data or the program output.
- \* Indicates that the observed water surface elevation given does not match the atlas values for the storm in concern. These values were taken from "Bridge Waterways Analysis Model: Research Report", Report No. FHWA/RD - 86/108. The values given in the report suggest that the observed water surface elevations given on the atlas for these sections were inadvertently switched with those from the lower-discharge event.
- \*\* Relative Error Squared is equal to the square of the absolute error divided by the depth: (Abs. Error / Depth )<sup>2</sup>.
- \*\*\* Standard Error is equal to the square root of the Relative Error Squared divided by the number of RES values summed: (Rel. Error Sq / n)<sup>0.5</sup>

BUCKHORN CREEK Q=4150 cfs

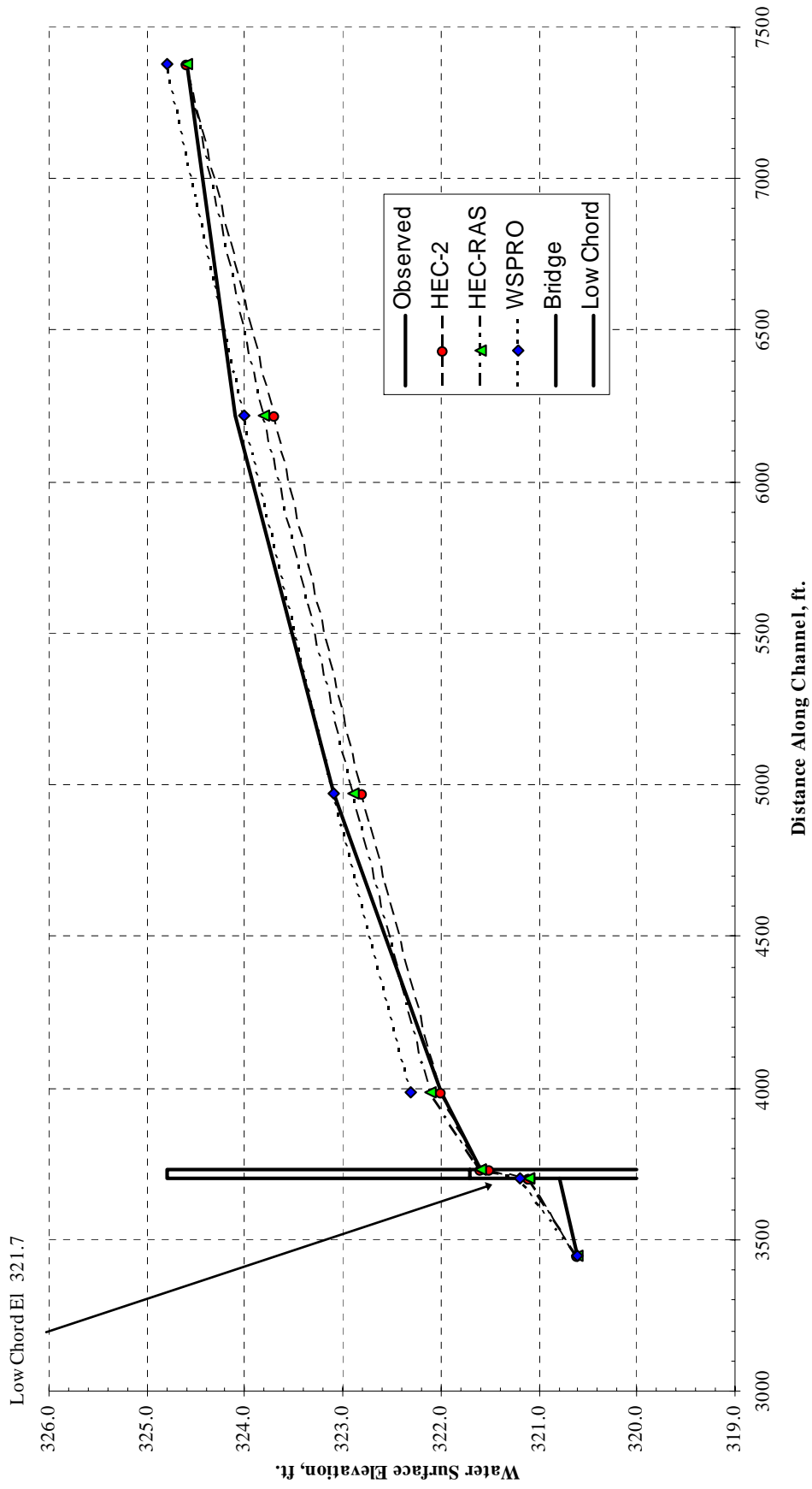



OKATAMA CREEK NEAR MAGEE, MISSISSIPPI Q = 16100 cfs

	Computed Results From:													
	HEC-2						HEC-RAS						WSPRO	
	Channel Distance, ft	Section Minimum Elevation, ft	Observed WSEL, ft	Depth, ft	WSEL, ft	Absolute Error, ft	Relative Error Squared ***	WSEL, ft	Absolute Error, ft	Relative Error Squared ***	WSEL, ft	Absolute Error, ft	Relative Error Squared ***	
5 EX1	8055	345.3	363.7	18.4	363.7	0.0		363.7	0.0		363.7	0.0		
6 EX	8580	344.7	363.8*	19.1	364.0	0.2		364.0	0.2		364.0	0.2		
6.1	8800	344.7	363.8*	19.1	363.5	-0.3	2.47E-04	363.4	-0.4	4.39E-04	364.4	0.6	9.87E-04	
BR	8802	344.2	NA		365.7			365.8			NA			
BR	8834	344.2	NA		365.9			366.0			NA			
6.4	8836	351.8	NA		365.8			366.0			NA			
7 AP	9056	351.8	367.2	15.4	367.1	-0.1	4.22E-05	367.3	0.1	4.22E-05	367.3	0.1	4.22E-05	
8	9712	351.9	367.4	15.5	367.2	-0.2	1.66E-04	367.4	0.0	0.00E+00	367.4	0.0	0.00E+00	
9	11132	353.5	367.8	14.3	367.5	-0.3		367.7	-0.1		367.7	-0.1		
11	12452	353.4	368.2	14.8	368.0	-0.2		368.2	0.0		368.2	0.0		

Sum of Rel. Error Squared: 0.0005

Standard Error\*\*\*: 0.012

0.0005

0.013

0.0010

0.019

**EXPLANATION OF SYMBOLS:**

- EX Denotes the section downstream of the bridge where effective flow width is assumed to have expanded to the full floodplain width. In this study the distance to full expansion is assumed to be approximately equal to the transverse width of the bridge opening, unless otherwise noted.
- EX1 Denotes a section approx. 1 times the average bridge constriction width downstream from the bridge. This is considered the full expansion section for the HEC-2 and HEC-RAS runs at this site.
- BR Denotes a section just inside the bridge.
- AP Denotes the section located upstream of the bridge a distance approximately equal to the transverse width of the bridge opening.
- NA Indicates that the value is not available from the data or the program output.
- \* Indicates that the observed water surface value is questionable either because there were very few values recorded on the atlas and/or because those that have been provided are not located within the active flow area
- \*\* Relative Error Squared is equal to the square of the absolute error divided by the depth: (Abs. Error / Depth )<sup>2</sup>.
- \*\*\* Standard Error is equal to the square root of the Relative Error Squared divided by the number of RES values summed: (Rel. Error Sq / n)<sup>0.5</sup>

OKATAMA CREEK NEAR MAGEE Q = 16100 cfs

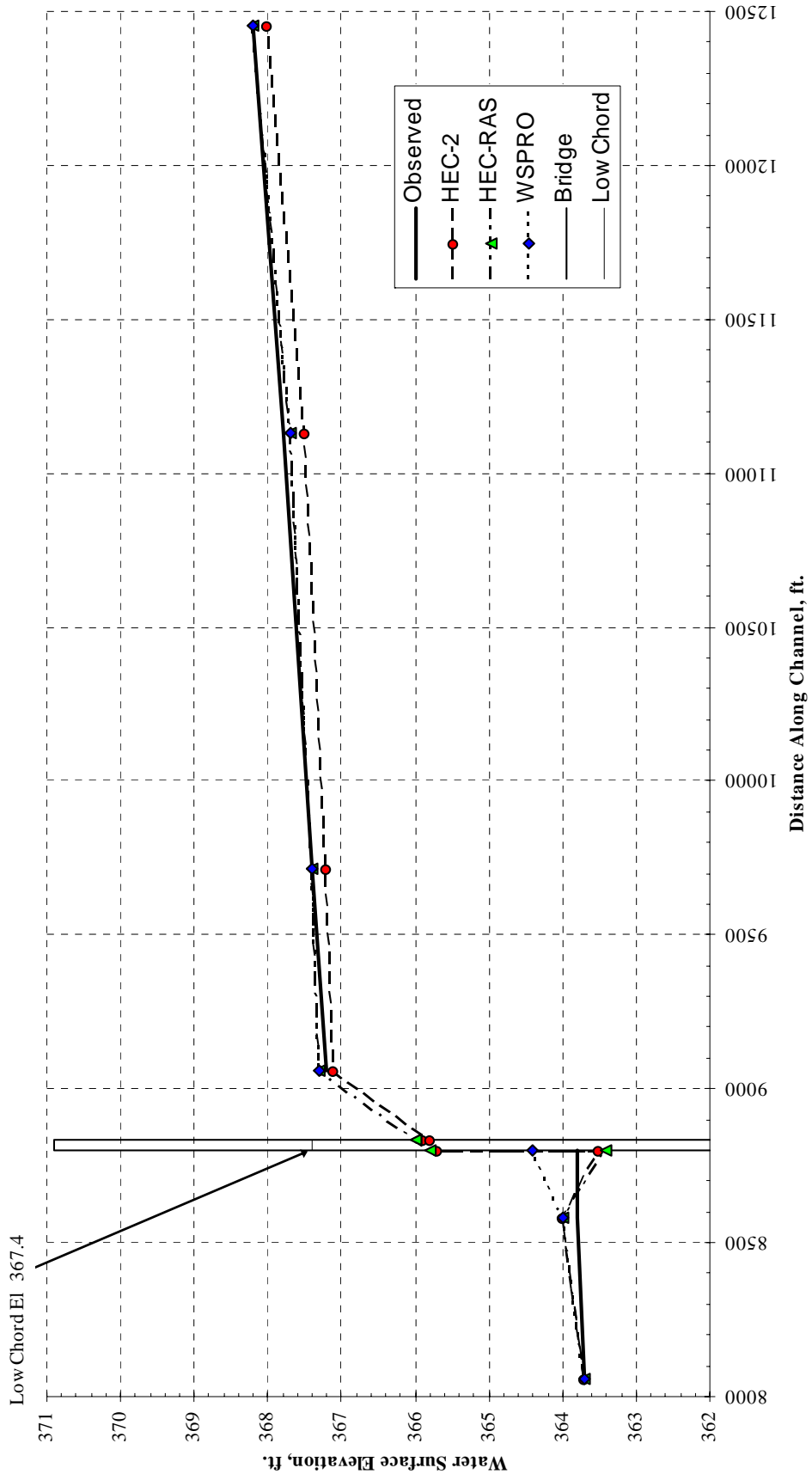

OKATAMA CREEK NEAR MAGEE, MISSISSIPPI Q = 12100 cfs

	Computed Results From:														
	HEC-2				HEC-RAS (energy only)				WSPRO						
	Channel Distance, ft	Section Minimum Elevation, ft	Observed WSEL, ft	Depth, ft	WSEL, ft	Absolute Error, ft	Relative Error Squared **	WSEL, ft	Absolute Error, ft	Relative Error Squared **	WSEL, ft	Absolute Error, ft	Relative Error Squared **		
4	3720	359.7	369.5	9.8	369.5	0.0		369.5	0.0		369.5	0.0			
5 EX	4075	359.0	369.8*	10.8	369.8	0.0		369.8	0.0		369.8	0.0			
5.1	4235	362.2	370.0*	7.8	369.4	-0.6	5.92E-03	369.5	-0.5	4.11E-03	371.0	1.0	1.64E-02		
BR	4237	357.7	NA		369.4			369.5			NA				
BR	4255	357.7	NA		369.7			369.9			NA				
5.4	4257	359.5	NA		369.9			370.0			NA				
6 AP	4417	359.5	371.9*	12.4	371.5	-0.4	1.04E-03	371.5	-0.4	1.04E-03	372.6	0.7	3.19E-03		
7	4780	360.1	372.0	11.9	371.6	-0.4	1.13E-03	371.7	-0.3	6.36E-04	372.7	0.7	3.46E-03		
8	5780	359.4	372.3	12.9	372.0	-0.3	5.41E-04	372.0	-0.3	5.41E-04	372.9	0.6	2.16E-03		
9	7650	360.6	373.7	13.1	373.5	-0.2		373.5	-0.2		373.9	0.2			
				Sum of Rel. Error Squared:				0.0086				0.0063			
				Standard Error***:				0.046				0.040			

0.0252  
0.079

EXPLANATION OF SYMBOLS:

- EX Denotes the section downstream of the bridge where effective flow width is assumed to have expanded to the full floodplain width. In this study the distance to full expansion is assumed to be approximately equal to the transverse width of the bridge opening, unless otherwise noted.
- BR Denotes a section just inside the bridge.
- AP Denotes the section located upstream of the bridge a distance approximately equal to the transverse width of the bridge opening.
- NA Indicates that the value is not available from the data or the program output.
- \* Indicates that the observed water surface value is questionable either because there were very few values recorded on the atlas and/or because those that have been provided are not located within the active flow area. The values shown here are taken from "Bridge Waterways Analysis Model: Research Report", Report No. FHWA / RD - 86 - 108.
- \*\* Relative Error Squared is equal to the square of the absolute error divided by the depth: (Abs. Error / Depth )<sup>2</sup>.
- \*\*\* Standard Error is equal to the square root of the Relative Error Squared divided by the number of RES values summed: (Rel. Error Sq / n)<sup>0.5</sup>

OKATAMA CREEK EAST OF MAGEE Q = 12100 cfs

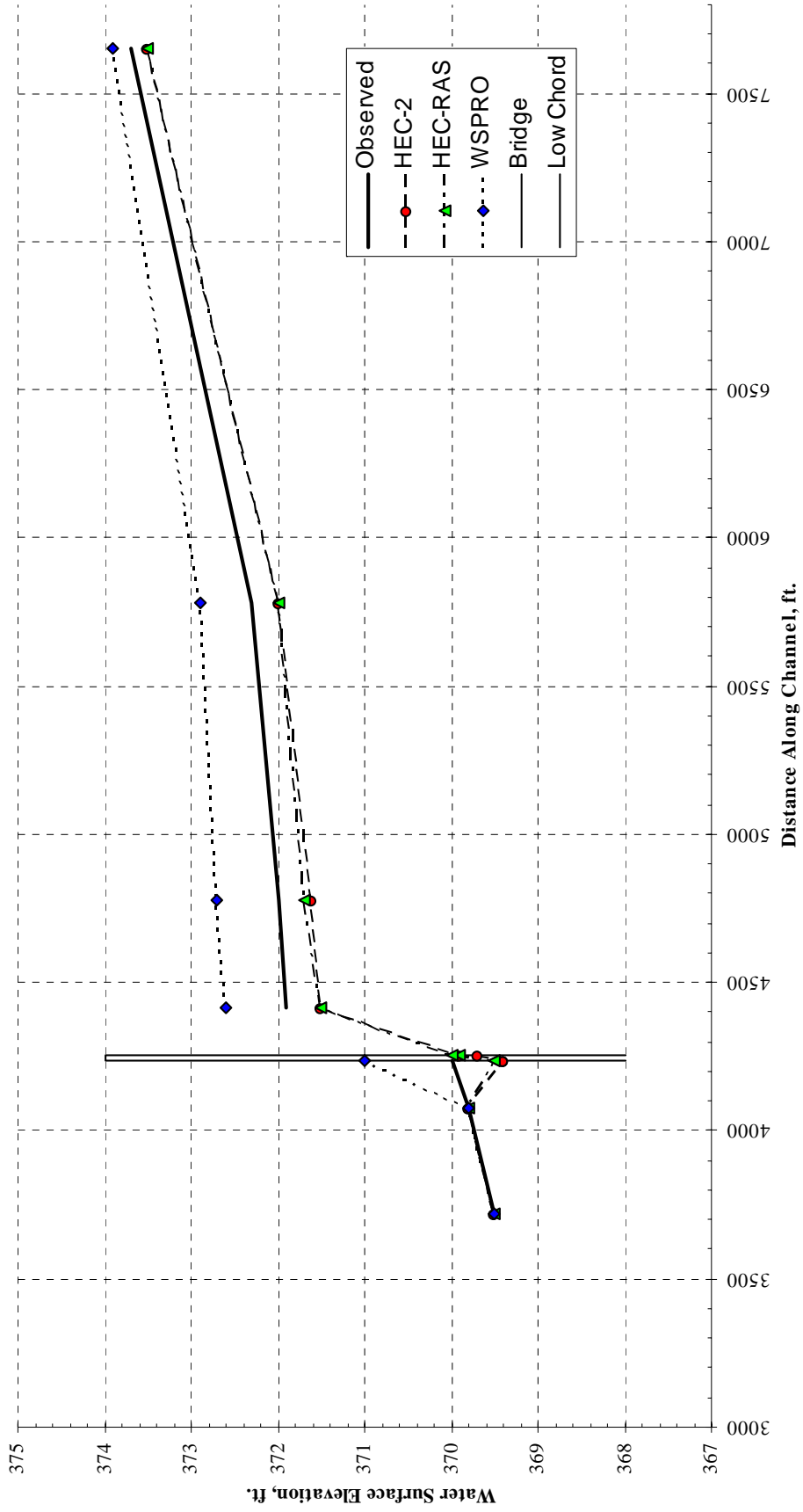

	Computed Results From:													
	HEC-2						HEC-RAS			WSPRO				
	Channel Distance, ft	Section Minimum Elevation, ft	Observed WSEL, ft	Depth, ft	WSEL, ft	Absolute Error, ft	Relative Error Squared **	WSEL, ft	Absolute Error, ft	Relative Error Squared **	WSEL, ft	Absolute Error, ft	Relative Error Squared **	
4 EX	3060	349.7	357.0	7.3	357.0	0.0	3.91E-03	357.0	0.0	5.62E-03	357.0	0.0	1.56E-02	
4.1	3313	349.8	357.8	8.0	358.3	0.5	3.91E-03	358.4	0.6	5.62E-03	358.8	1.0	1.56E-02	
BR	3314	350.0	NA		358.3			358.4			NA			
BR	3338	350.0	NA		358.4			358.6			NA			
4.4	3339	349.8	359.0		358.5	-0.5	1.84E-03	358.6	-0.4	8.16E-04	359.4	0.3	1.84E-03	
5 AP	3592	352.1	359.1	7.0	358.8	-0.3	1.84E-03	358.9	-0.2	2.98E-03	360.5	-0.2	1.32E-03	
6	5322	355.2	360.7	5.5	360.4	-0.3	2.98E-03	360.4	-0.3	2.98E-03	362.0	-0.3	1.32E-03	
7	6772	354.5	362.3	7.8	361.9	-0.4	2.98E-03	362.0	-0.3	2.98E-03	362.0	-0.3	1.32E-03	
						Sum of Rel. Error Squared:						0.0087	0.0094	0.0188
						Standard Error***:						0.054	0.056	0.079

**EXPLANATION OF SYMBOLS:**

- EX Denotes the section downstream of the bridge where effective flow width is assumed to have expanded to the full floodplain width. In this study the distance to full expansion is assumed to be approximately equal to the transverse width of the bridge opening, unless otherwise noted.
- BR Denotes a section just inside the bridge.
- AP Denotes the section located upstream of the bridge a distance approximately equal to the transverse width of the bridge opening.
- NA Indicates that the value is not available from the data or the program output.
- \* Indicates that the observed water surface value is questionable either because there were very few values recorded on the atlas and/or because those that have been provided are not located within the active flow area
- \*\* Relative Error Squared is equal to the square of the absolute error divided by the depth: (Abs. Error / Depth )<sup>2</sup>.
- \*\*\* Standard Error is equal to the square root of the Relative Error Squared divided by the number of RES values summed: (Rel. Error Sq / n)<sup>0.5</sup>

PEA CREEK Q = 1780 cfs

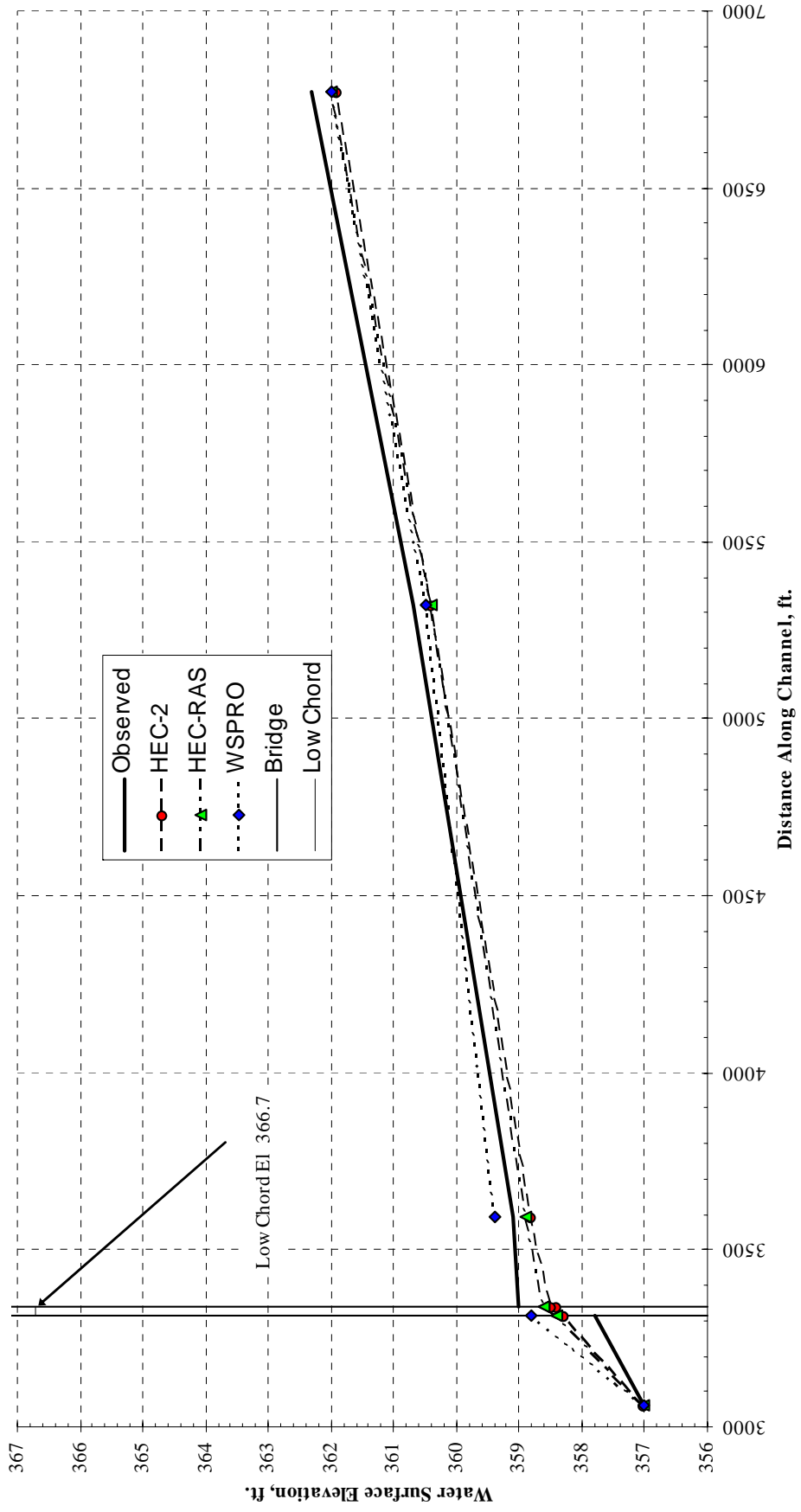

**POLEY CREEK, ALABAMA Q = 1900 cfs**

	Computed Results From:													
	HEC-2						HEC-RAS						WSPRO	
	Channel Distance, ft	Section Minimum Elevation, ft	Observed WSEL, ft	Depth, ft	WSEL, ft	Absolute Error, ft	Relative Error Squared **	WSEL, ft	Absolute Error, ft	Relative Error Squared **	WSEL, ft	Absolute Error, ft	Relative Error Squared **	
4 EX	1985	226.0	232.9	6.9	232.9	0.0	6.78E-03	232.9	0.0	6.78E-03	232.9	0.0	1.12E-02	
4.1	2187	224.7	233.2	8.5	233.9	0.7	6.78E-03	233.9	0.7	6.78E-03	234.1	0.9	1.12E-02	
BR	2189	224.7	NA		233.9			233.9			NA			
BR	2217	224.7	NA		234.2			234.3			NA			
4.4	2219	224.7	234.6	6.7	234.3	-0.3	8.91E-04	234.3	-0.3	2.23E-04	235.0	0.2	8.91E-04	
5 AP	2421	228.1	234.8	6.7	234.6	-0.2	8.91E-04	234.7	-0.1	1.11E-03	235.7	0.1	1.11E-03	
6	3501	232.6	235.6	3.0	235.4	-0.2	4.44E-03	235.5	-0.1	1.11E-03	236.8	0.2	0.0132	
7	4341	234.3	236.6	2.3	236.8	0.2	0.0121	236.8	0.2	0.0081	236.8	0.2	0.066	
						Sum of Rel. Error Squared:						0.0121	0.0081	0.0132
						Standard Error***:						0.064	0.052	0.066

**EXPLANATION OF SYMBOLS:**

- EX Denotes the section downstream of the bridge where effective flow width is assumed to have expanded to the full floodplain width. In this study the distance to full expansion is assumed to be approximately equal to the transverse width of the bridge opening, unless otherwise noted.
- BR Denotes a section just inside the bridge.
- AP Denotes the section located upstream of the bridge a distance approximately equal to the transverse width of the bridge opening.
- NA Indicates that the value is not available from the data or the program output.
- \* Indicates that the observed water surface value is questionable either because there were very few values recorded on the atlas and/or because those that have been provided are not located within the active flow area
- \*\* Relative Error Squared is equal to the square of the absolute error divided by the depth: (Abs. Error / Depth )<sup>2</sup>.
- \*\*\* Standard Error is equal to the square root of the Relative Error Squared divided by the number of RES values summed: (Rel. Error Sq / n)<sup>0.5</sup>

**POLEY CREEK Q = 1900 cfs**

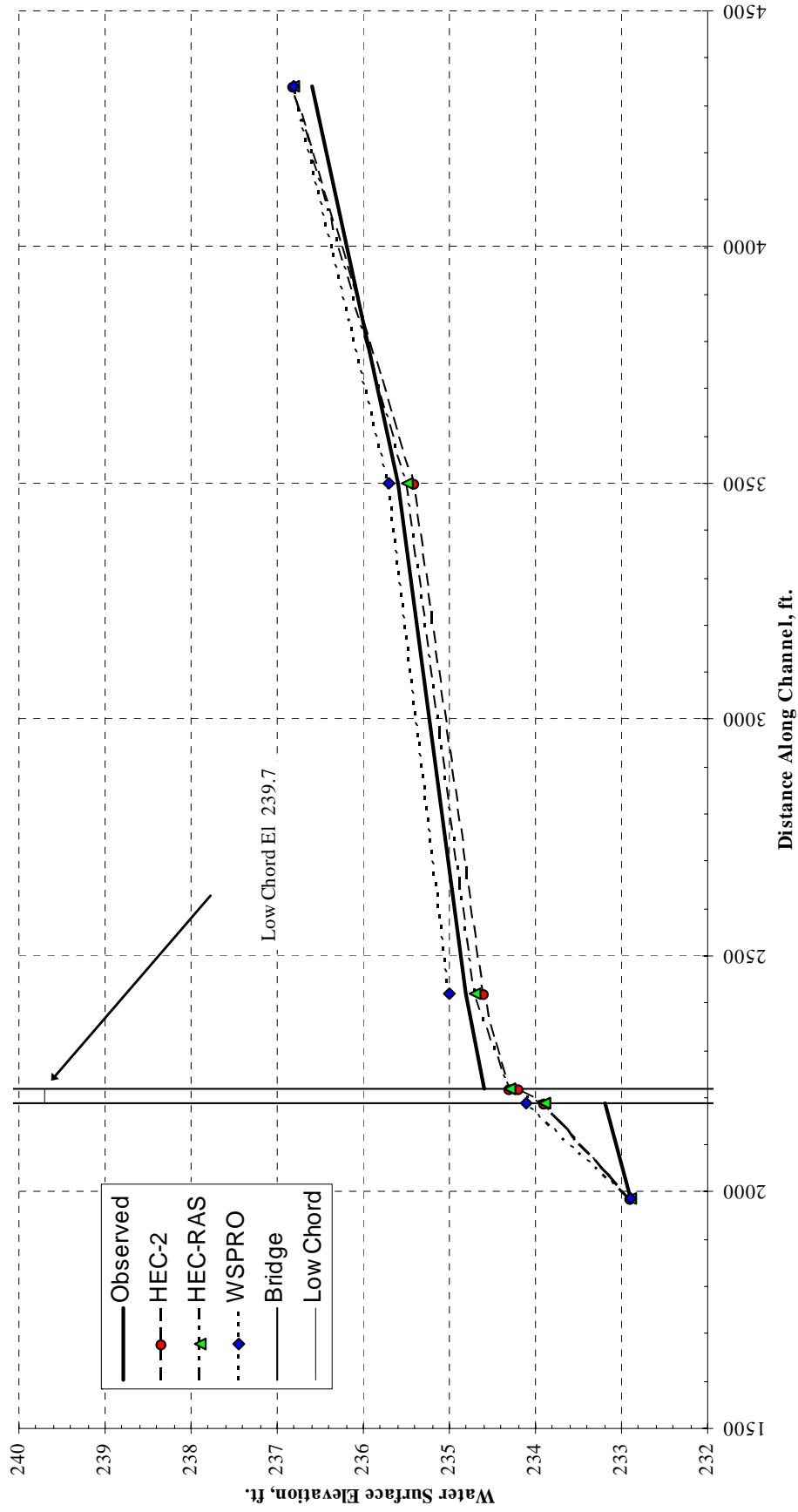



**POLEY CREEK, ALABAMA Q = 4600 cfs**

	Computed Results From:													
	HEC-2						HEC-RAS						WSPRO	
	Channel Distance, ft	Section Minimum Elevation, ft	Observed WSEL, ft	Depth, ft	WSEL, ft	Absolute Error, ft	Relative Error Squared **	WSEL, ft	Absolute Error, ft	Relative Error Squared **	WSEL, ft	Absolute Error, ft	Relative Error Squared **	
4 EX	1985	226.0	234.9	8.9	234.9	0.0	3.20E-03	234.9	0.0	3.20E-03	234.9	0.0	5.70E-03	
4.1	2187	224.7	235.3	10.6	235.9	0.6	3.20E-03	235.9	0.6	3.20E-03	236.1	0.8	5.70E-03	
BR	2189	224.7	NA		235.9			236.0			NA			
BR	2217	224.7	NA		236.6			236.6			NA			
4.4	2219	224.7	237.0		236.7	-0.3		236.7	-0.3		NA			
5 AP	2421	228.1	237.2	9.1	237.2	0.0	0.00E+00	237.2	0.0	0.00E+00	237.6	0.4	1.93E-03	
6	3501	232.6	238.0	5.4	237.9	-0.1	3.43E-04	238.0	0.0	0.00E+00	238.3	0.3	3.09E-03	
7	4341	234.3	239.0	4.7	238.9	-0.1		239.0	0.0		239.2	0.2		
						Sum of Rel. Error Squared:						0.0035	0.0032	0.0107
						Standard Error***:						0.034	0.033	0.060

**EXPLANATION OF SYMBOLS:**

- EX Denotes the section downstream of the bridge where effective flow width is assumed to have expanded to the full floodplain width. In this study the distance to full expansion is assumed to be approximately equal to the transverse width of the bridge opening, unless otherwise noted.
- BR Denotes a section just inside the bridge.
- AP Denotes the section located upstream of the bridge a distance approximately equal to the transverse width of the bridge opening.
- NA Indicates that the value is not available from the data or the program output.
- \* Indicates that the observed water surface value is questionable either because there were very few values recorded on the atlas and/or because those that have been provided are not located within the active flow area
- \*\* Relative Error Squared is equal to the square of the absolute error divided by the depth: (Abs. Error / Depth )<sup>2</sup>.
- \*\*\* Standard Error is equal to the square root of the Relative Error Squared divided by the number of RES values summed: (Rel. Error Sq / n)<sup>0.5</sup>

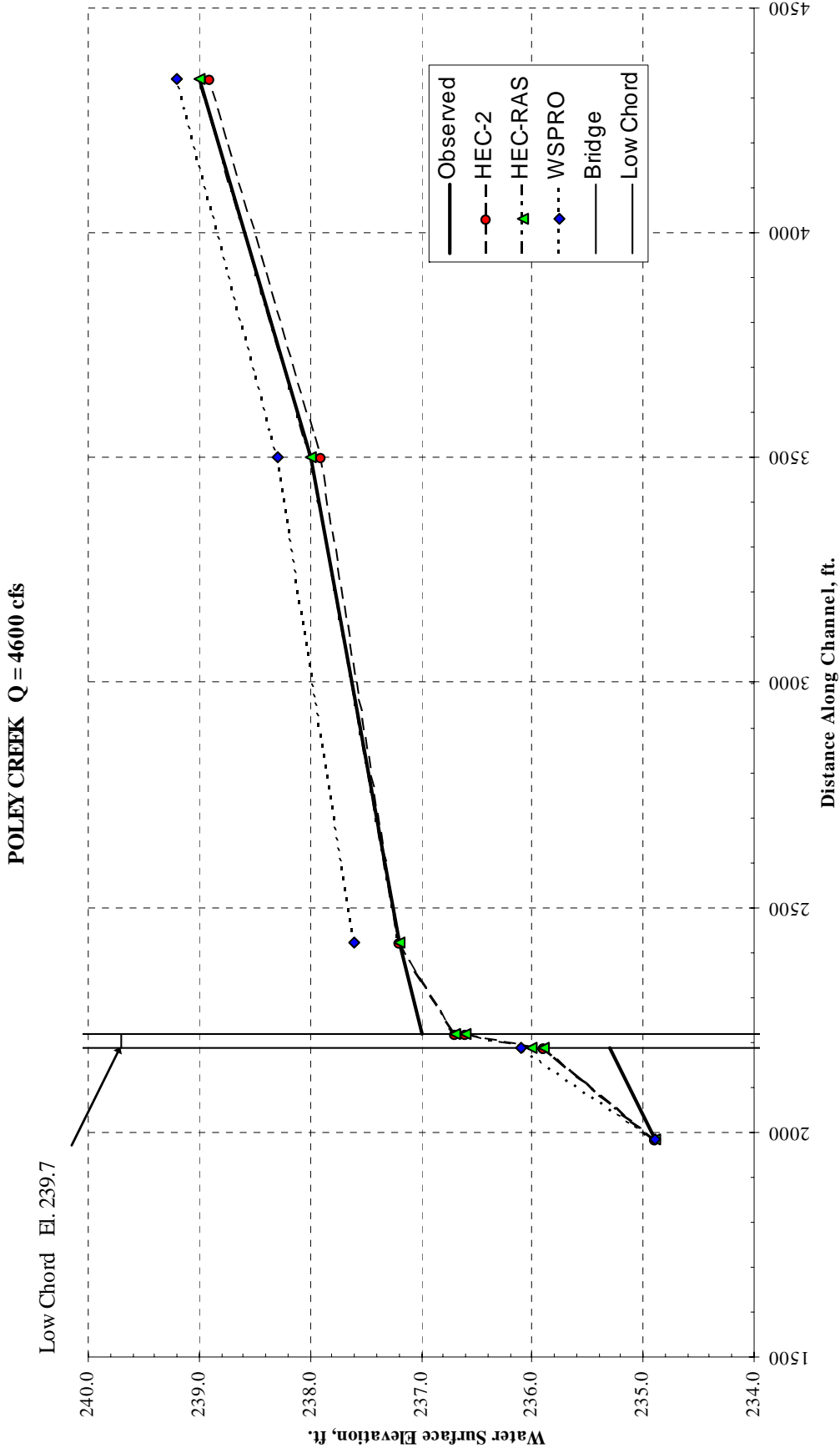

	Computed Results From:													
	HEC-2						HEC-RAS						WSPRO	
	Channel Distance, ft	Section Minimum Elevation, ft	Observed WSEL, ft	Depth, ft	WSEL, ft	Absolute Error, ft	Relative Error Squared ***	WSEL, ft	Absolute Error, ft	Relative Error Squared ***	WSEL, ft	Absolute Error, ft	Relative Error Squared ***	
5 EX	7109	94.4	109.6	15.2	109.6	0.0	1.48E-03	109.6	0.0	1.48E-03	109.6	0.0	1.64E-04	
5.4	7650	94.3	109.9	15.6	110.5	0.6	1.48E-03	110.5	0.6	1.48E-03	110.1	0.2	1.64E-04	
BR	7652	94.3	NA	NA	110.5	NA	NA	110.5	NA	NA	NA	NA	NA	
BR	7678	94.3	NA	NA	110.6	NA	NA	110.7	NA	NA	NA	NA	NA	
5.7	7680	94.3	110.7	16.4	110.7	0.0	1.48E-03	110.7	0.0	1.48E-03	110.9	0.0	1.64E-04	
6 AP	8221	95.4	110.9	15.5	111.0	0.1	4.16E-05	111.0	0.1	4.16E-05	110.9	0.0	0.00E+00	
7	8591	101.1	111.1	10.0	111.1	0.0	0.00E+00	111.1	0.0	0.00E+00	111.0	-0.1	1.00E-04	
8	10741	102.0	111.9	9.9	111.6	-0.3	0.00E+00	111.6	-0.3	0.00E+00	111.6	-0.3	1.00E-04	
Sum of Rel. Error Squared:						0.0015	0.0015	0.0015	0.0015	0.0015	0.0015	0.0015	0.0003	
Standard Error***:						0.023	0.023	0.023	0.023	0.023	0.023	0.023	0.009	

**EXPLANATION OF SYMBOLS:**

- EX Denotes the section downstream of the bridge where effective flow width is assumed to have expanded to the full floodplain width. In this study the distance to full expansion is assumed to be approximately equal to the transverse width of the bridge opening, unless otherwise noted.
- BR Denotes a section just inside the bridge.
- AP Denotes the section located upstream of the bridge a distance approximately equal to the transverse width of the bridge opening.
- NA Indicates that the value is not available from the data or the program output.
- \* Indicates that the observed water surface value is questionable either because there were very few values recorded on the atlas and/or because those that have been provided are not located within the active flow area
- \*\* Relative Error Squared is equal to the square of the absolute error divided by the depth: (Abs. Error / Depth )<sup>2</sup>.
- \*\*\* Standard Error is equal to the square root of the Relative Error Squared divided by the number of RES values summed: (Rel. Error Sq / n)<sup>0.5</sup>

TENNILE CREEK Q = 6400 cfs

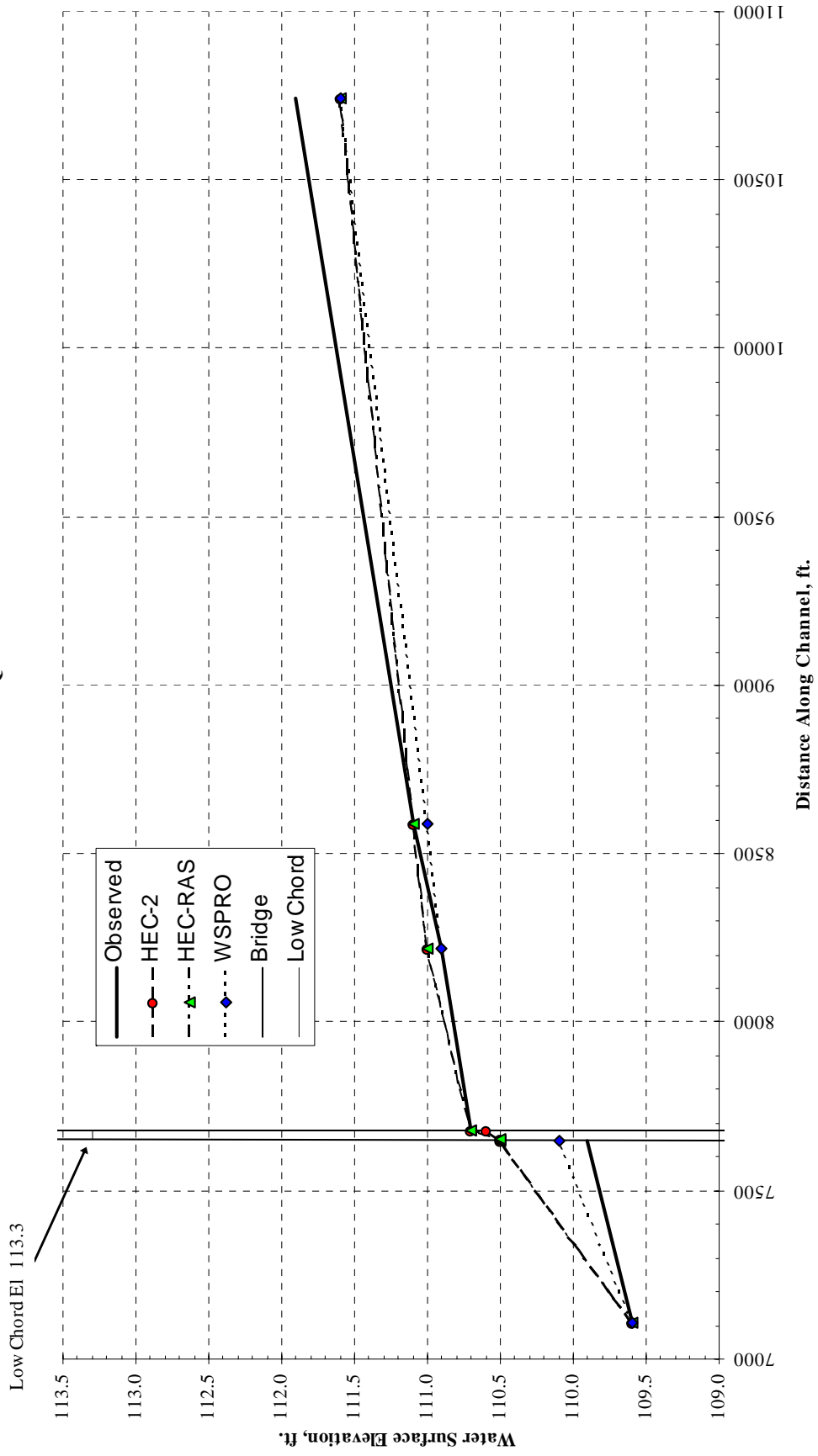

THOMPSON CREEK, MISSISSIPPI Q = 3800 cfs

Computed Results From:												
HEC-2						HEC-RAS			WSPRO			
Channel Distance, ft	Section Minimum Elevation, ft	Observed WSEL, ft	Depth, ft	WSEL, ft	Absolute Error, ft	Relative Error Squared ***	WSEL, ft	Absolute Error, ft	Relative Error Squared ***	WSEL, ft	Absolute Error, ft	Relative Error Squared ***
4 EX1	181.4	198.6	17.2	198.6			198.6			198.6		
5 EX	187.0	NA		NA			NA			199.2		
5.1	187.0	199.7	12.7	199.6	-0.1	6.20E-05	199.6	-0.1	6.20E-05	199.9	0.2	2.48E-04
5.15	187.0	NA		199.6			199.7			NA		
5.16	187.0	NA		199.7			199.8			NA		
BR	187.0	NA		199.7			199.8			NA		
BR	187.0	NA		199.8			199.9			NA		
5.35	187.0	NA		199.8			199.9			NA		
5.36	187.0	NA		200.1			200.2			200.3		
5.4	187.0	199.8	12.8	200.1	0.3		200.2	0.4		NA		
5.5 AP	187.0	200.3	13.3	200.6	0.3	5.09E-04	200.6	0.3	5.09E-04	200.9	0.6	2.04E-03
6	187.2	NA		200.8			200.8			201.0		
7	186.9	201.0	14.1	201.2	0.2	2.01E-04	201.2	0.2	2.01E-04	201.4	0.4	8.05E-04
Sum of Rel. Error Squared:						0.0008	0.0008			0.0031		
Standard Error***:						0.016	0.016			0.032		

EXPLANATION OF SYMBOLS:

- EX Denotes the section downstream of the bridge where effective flow width is assumed to have expanded to the full floodplain width. In this study the distance to full expansion is assumed to be approximately equal to the transverse width of the bridge opening, unless otherwise noted.
- EX1 Denotes a section approx. 1 times the average bridge constriction width downstream from the bridge. This is considered the full expansion section for the HEC-2 and HEC-RAS runs at this site.
- BR Denotes a section just inside the bridge.
- AP Denotes the section located upstream of the bridge a distance approximately equal to the transverse width of the bridge opening.
- NA Indicates that the value is not available from the data or the program output.
- \* Indicates that the observed water surface value is questionable either because there were very few values recorded on the atlas and/or because those that have been provided are not located within the active flow area
- \*\* Relative Error Squared is equal to the square of the absolute error divided by the depth: (Abs. Error / Depth )^2.
- \*\*\* Standard Error is equal to the square root of the Relative Error Squared divided by the number of RES values summed: (Rel. Error Sq / n)^0.5

THOMPSON CREEK Q = 3800 cfs

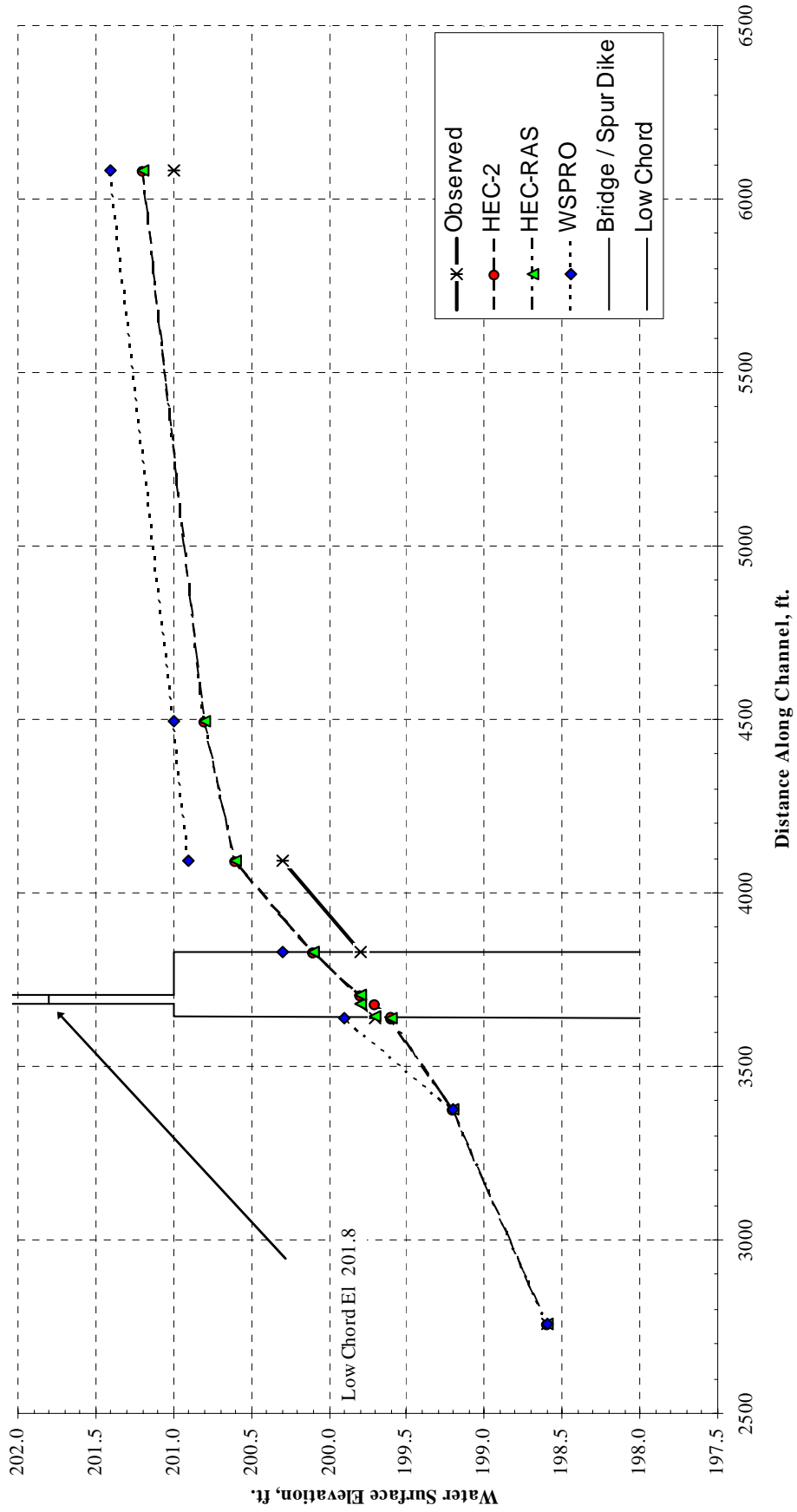

**YELLOW RIVER, ALABAMA Q = 2000 cfs**

Computed Results From:									
HEC-2					HEC-RAS			WSPRO	
Channel Distance, ft	Section Minimum Elevation, ft	Observed WSEL, ft	Depth, ft	WSEL, ft	Absolute Error, ft	Relative Error Squared ***	WSEL, ft	Absolute Error, ft	Relative Error Squared ***
3 EX	224.8	233.1	8.3	233.1	0.0	1.68E-03	233.1	0.0	1.68E-03
3.1	223.5	233.3	9.8	233.7	0.4	1.68E-03	233.7	0.4	1.68E-03
BR	223.5	NA		233.7			NA		
BR	223.5	NA		233.8			NA		
3.4	223.5	233.9		233.8	-0.1	2.01E-04	234.2	0.0	0.00E+00
4 AP	227.1	234.2	7.1	234.1	-0.1	2.01E-04	234.3	0.1	2.01E-04
5	227.8	234.7	6.9	234.7	0.0	0.00E+00	234.9	0.2	8.33E-04
Sum of Rel. Error Squared:					0.0019	0.0019	0.0019	0.0027	0.0027
Standard Error***:					0.025	0.025	0.025	0.030	0.030

**EXPLANATION OF SYMBOLS:**

- EX Denotes the section downstream of the bridge where effective flow width is assumed to have expanded to the full floodplain width. In this study the distance to full expansion is assumed to be approximately equal to the transverse width of the bridge opening, unless otherwise noted.
- BR Denotes a section just inside the bridge.
- AP Denotes the section located upstream of the bridge a distance approximately equal to the transverse width of the bridge opening.
- NA Indicates that the value is not available from the data or the program output.
- \* Indicates that the observed water surface value is questionable either because there were very few values recorded on the atlas and/or because those that have been provided are not located within the active flow area
- \*\* Relative Error Squared is equal to the square of the absolute error divided by the depth: (Abs. Error / Depth )^2.
- \*\*\* Standard Error is equal to the square root of the Relative Error Squared divided by the number of RES values summed: (Rel. Error Sq / n)^0.5

**YELLOW RIVER Q = 2000 cfs**

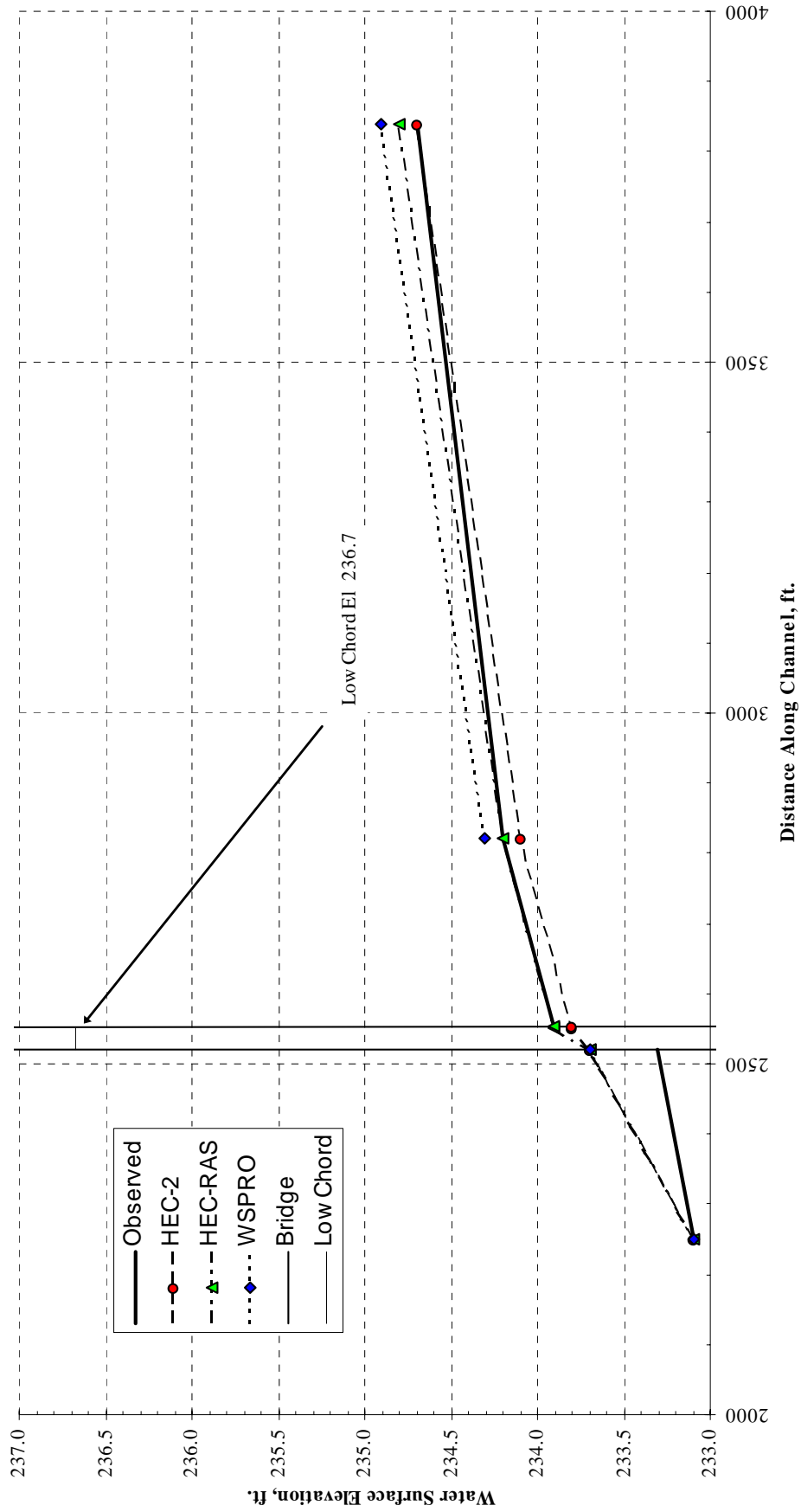



**YELLOW RIVER, ALABAMA Q = 6603 cfs**

	Computed Results From:												
	HEC-2				HEC-RAS				WSPRO				
	Channel Distance, ft	Section Minimum Elevation, ft	Observed WSEL, ft	Depth, ft	WSEL, ft	Absolute Error, ft	Relative Error Squared ***	WSEL, ft	Absolute Error, ft	Relative Error Squared ***	WSEL, ft	Absolute Error, ft	Relative Error Squared ***
3 EX	2251	224.8	235.7	11.0	235.7	0.0	2.32E-03	235.7	0.0	0.0048	235.7	0.0	0.0057
3.1 BR	2520	223.5	236.0	12.5	236.6	0.6	2.32E-03	236.7	0.7	0.040	236.7	0.7	0.043
BR	2521	223.5	NA		236.6			236.7			NA		
BR	2552	223.5	NA		236.9			237.2			NA		
3.4 AP	2553	223.5	237.3	10.2	237.0	-0.3	3.88E-04	237.3	0.0	0.0048	237.8	0.5	2.42E-03
4 AP	2822	227.1	237.3	10.3	237.5	0.2	9.37E-05	237.7	0.4	0.040	237.8	0.1	9.37E-05
5	3839	227.8	238.1	10.3	238.0	-0.1	9.37E-05	238.2	0.1	0.0048	238.2	0.1	0.0057
				Sum of Rel. Error Squared:									0.0028
				Standard Error***:									0.031

**EXPLANATION OF SYMBOLS:**

- EX Denotes the section downstream of the bridge where effective flow width is assumed to have expanded to the full floodplain width. In this study the distance to full expansion is assumed to be approximately equal to the transverse width of the bridge opening, unless otherwise noted.
- BR Denotes a section just inside the bridge.
- AP Denotes the section located upstream of the bridge a distance approximately equal to the transverse width of the bridge opening.
- NA Indicates that the value is not available from the data or the program output.
- \* Indicates that the observed water surface value is questionable either because there were very few values recorded on the atlas and/or because those that have been provided are not located within the active flow area
- \*\* Relative Error Squared is equal to the square of the absolute error divided by the depth: (Abs. Error / Depth )^2.
- \*\*\* Standard Error is equal to the square root of the Relative Error Squared divided by the number of RES values summed: (Rel. Error Sq / n)^0.5

**YELLOW RIVER Q = 6603 cfs**

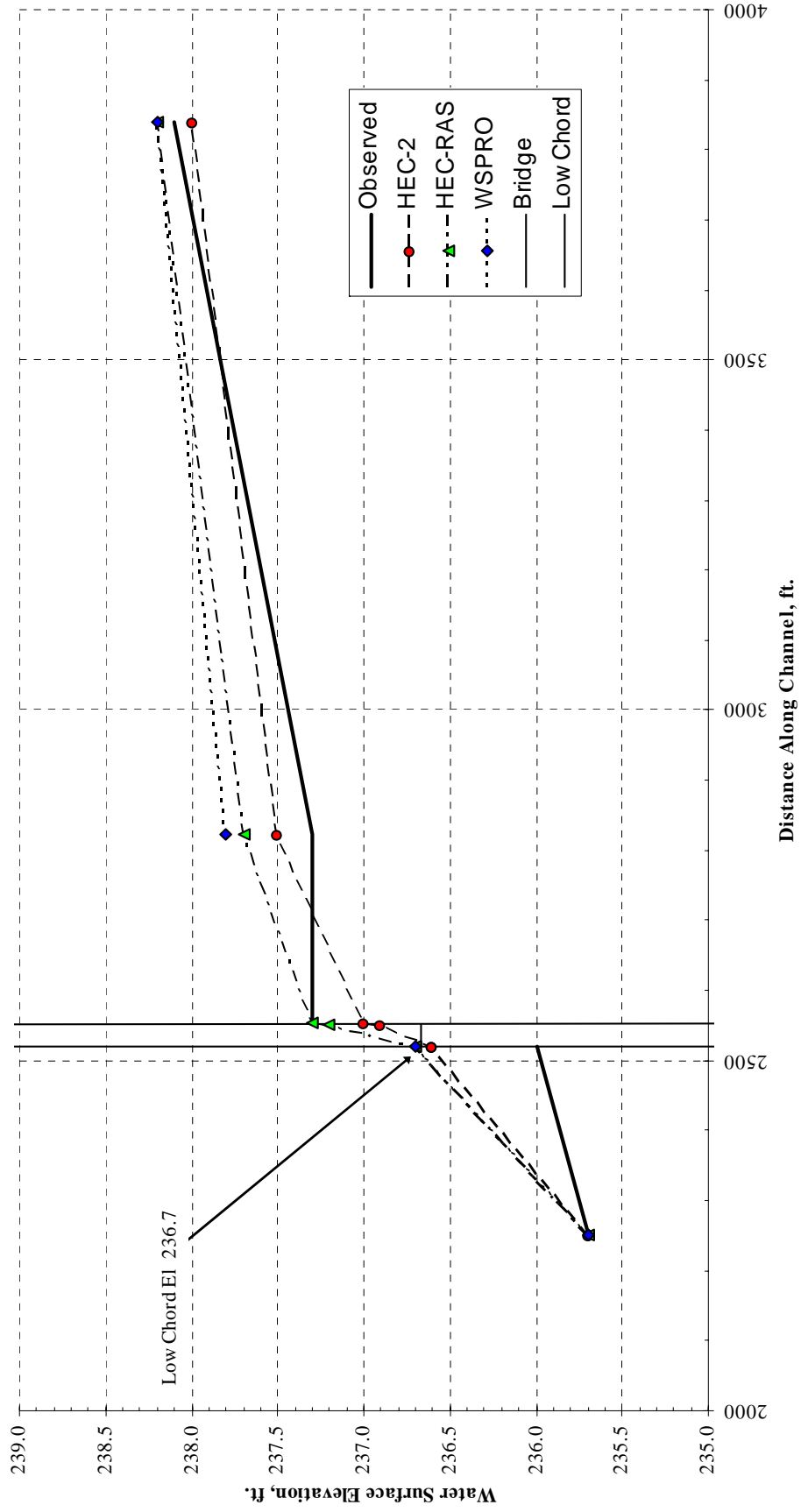

## **Comparison: HEC High Flow Methods**

HEC-2 Normal Bridge

HEC-2 Special Bridge

RAS Energy Only

RAS Pressure and Weir



BEAVER CREEK, LOUISIANA Q = 14000 cfs

Computed Results From:																
			HEC-2 (special bridge)				HEC-2 (normal bridge)				HEC-RAS (pressure & weir)				HEC-RAS (energy only)	
Channel Distance, ft	Section Minimum Elevation, ft	Observed WSEL, ft	Depth, ft	WSEL, ft	Absolute Error, ft	Relative Error Squared **	WSEL, ft	Absolute Error, ft	Relative Error Squared **	WSEL, ft	Absolute Error, ft	Relative Error Squared **	WSEL, ft	Absolute Error, ft	Relative Error Squared **	
3 EX	820	214.9	12.1	214.9	0.0	0.00E+00	214.9	0.0	0.00E+00	214.9	0.0	0.00E+00	214.9	0.0	6.30E-05	
4.1	1312	215.2	12.6	215.2	0.0	0.00E+00	215.2	0.0	0.00E+00	215.3	0.1	6.30E-05	215.3	0.1	6.30E-05	
BR	1313	NA		NA			215.2			215.5			215.5			
BR	1339	NA		NA			215.7			216.6			216.1			
4.4	1340	217.8*	15.2	215.9	-1.9	0.00E+00	215.8	-2.0	5.18E-05	216.5	-1.3	5.18E-05	216.1	-1.7	2.07E-04	
5 AP	1540	217.8	13.9	217.8	0.0	0.00E+00	217.7	-0.1	3.05E-05	217.9	0.1	0.00E+00	217.6	-0.2	1.22E-04	
6	2404	218.1	18.1	218.0	-0.1	3.05E-05	218.0	-0.1	3.05E-05	218.1	0.0	0.00E+00	217.9	-0.2	1.22E-04	
7	3224	218.4	13.4	218.4	0.0	0.00E+00	218.4	0.0	0.00E+00	218.6	0.2	0.00E+00	218.4	0.0	0.00E+00	
				Sum of Rel. Error Squared:				0.00001				0.0001				0.0004
				Standard Error***:				0.003				0.006				0.011

EXPLANATION OF SYMBOLS:

- EX Denotes the section downstream of the bridge where effective flow width is assumed to have expanded to the full floodplain width. In this study the distance to full expansion is assumed to be approximately equal to the transverse width of the bridge opening, unless otherwise noted.
- BR Denotes a section just inside the bridge.
- AP Denotes the section located upstream of the bridge a distance approximately equal to the transverse width of the bridge opening.
- NA Indicates that the value is not available from the data or the program output.
- \* Indicates that the observed water surface value is questionable either because there were very few values recorded on the atlas and/or because those that have been provided are not located within the active flow area
- \*\* Relative Error Squared is equal to the square of the absolute error divided by the depth:  $(\text{Abs. Error} / \text{Depth})^2$ .
- \*\*\* Standard Error is equal to the square root of the Relative Error Squared divided by the number of RES values summed:  $(\text{Rel. Error Sq} / n)^{0.5}$

BEAVER CREEK Q = 14000 cfs

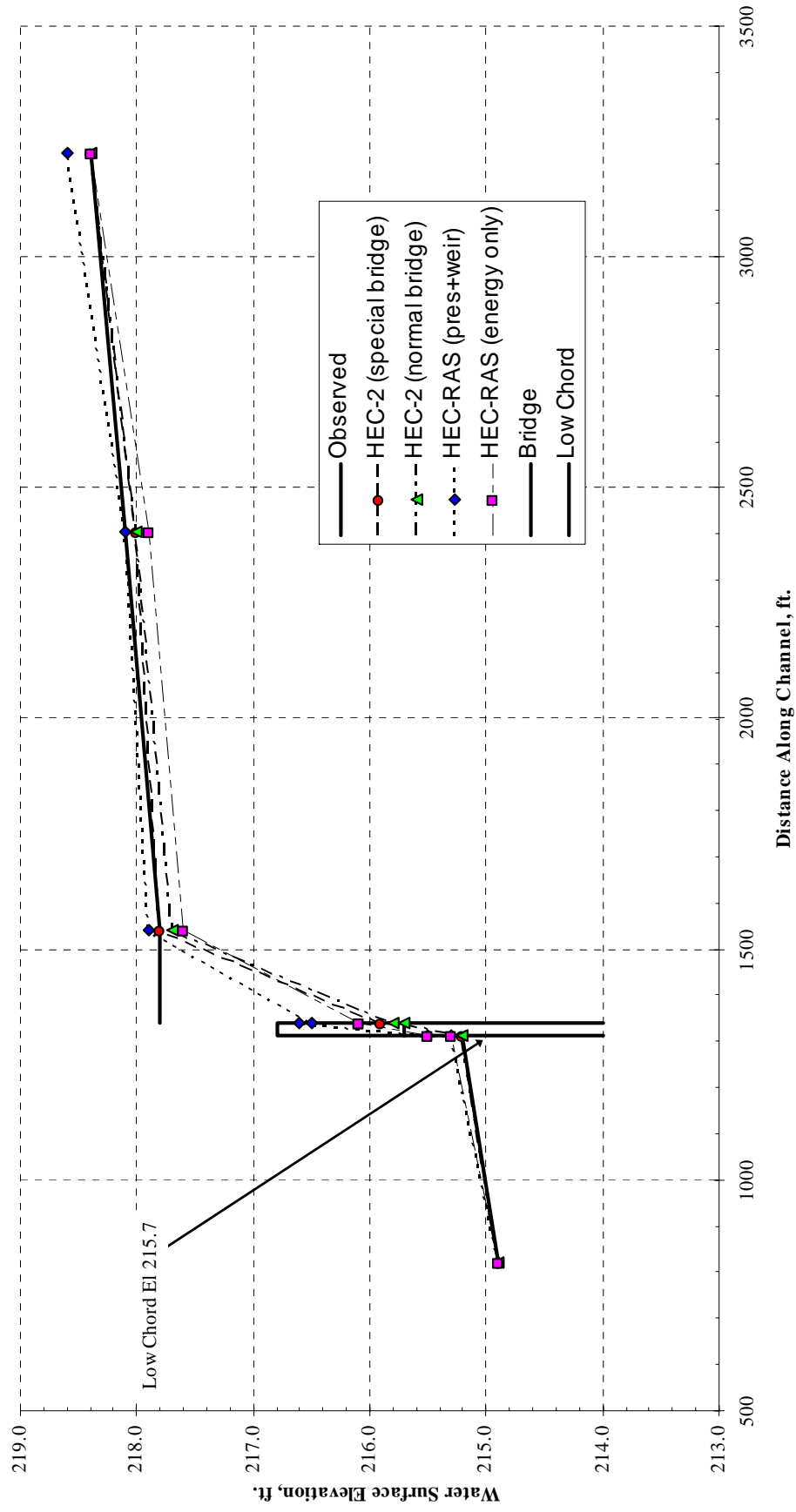

OKATAMA CREEK EAST OF MAGEE, MISSISSIPPI Q = 12100 cfs

Computed Results From:															
HEC-2 (special bridge)				HEC-2 (normal bridge)				HEC-RAS (pressure & weir)				HEC-RAS (energy only)			
Channel Distance, ft	Section Minimum Elevation, ft	Observed WSEL, ft	Depth, ft	WSEL, ft	Absolute Error, ft	Relative Error Squared **	WSEL, ft	Absolute Error, ft	Relative Error Squared **	WSEL, ft	Absolute Error, ft	Relative Error Squared **	WSEL, ft	Absolute Error, ft	Relative Error Squared **
4	3720	369.5	9.8	369.5	0.0		369.5	0.0		369.5	0.0		369.5	0.0	
5 EX	4075	369.8*	10.8	369.8	0.0		369.8	0.0		369.8	0.0		369.8	0.0	
5.1	4235	370.0*	7.8	369.4	-0.6	5.92E-03	369.4	-0.6	5.92E-03	369.5	-0.5	4.11E-03	369.5	-0.5	4.11E-03
BR	4237	NA		NA			369.4			369.5			369.5		
BR	4255	NA		NA			369.7			369.9			369.9		
5.4	4257	NA		369.7			369.9			370.0			370.0		
6 AP	4417	359.5	12.4	371.4	-0.5	1.63E-03	371.5	-0.4	1.04E-03	371.5	-0.4	1.04E-03	371.5	-0.4	1.04E-03
7	4780	372.0	11.9	371.5	-0.5	1.77E-03	371.6	-0.4	1.13E-03	371.7	-0.3	6.36E-04	371.7	-0.3	6.36E-04
8	5780	372.3	12.9	371.9	-0.4	9.61E-04	372.0	-0.3	5.41E-04	372.0	-0.3	5.41E-04	372.0	-0.3	5.41E-04
9	7650	373.7	13.1	373.5	-0.2		373.5	-0.2		373.5	-0.2		373.5	-0.2	
				Sum of Rel. Error Squared: 0.0103				0.0086				0.0063		0.0063	
				Standard Error***: 0.051				0.046				0.040		0.040	

EXPLANATION OF SYMBOLS:

- EX Denotes the section downstream of the bridge where effective flow width is assumed to have expanded to the full floodplain width. In this study the distance to full expansion is assumed to be approximately equal to the transverse width of the bridge opening, unless otherwise noted.
- BR Denotes a section just inside the bridge.
- AP Denotes the section located upstream of the bridge a distance approximately equal to the transverse width of the bridge opening.
- NA Indicates that the value is not available from the data or the program output.
- \* Indicates that the observed water surface value is questionable either because there were very few values recorded on the atlas and/or because those that have been provided are not located within the active flow area. The values shown here are taken from "Bridge Waterways Analysis Model: Research Report", Report No. FHWA / RD - 86 - 108.
- \*\* Relative Error Squared is equal to the square of the absolute error divided by the depth: (Abs. Error / Depth)<sup>2</sup>.
- \*\*\* Standard Error is equal to the square root of the Relative Error Squared divided by the number of RES values summed: (Rel. Error Sq / n)<sup>0.5</sup>

OKATAMA CREEK EAST OF MAGEE Q = 12100 cfs

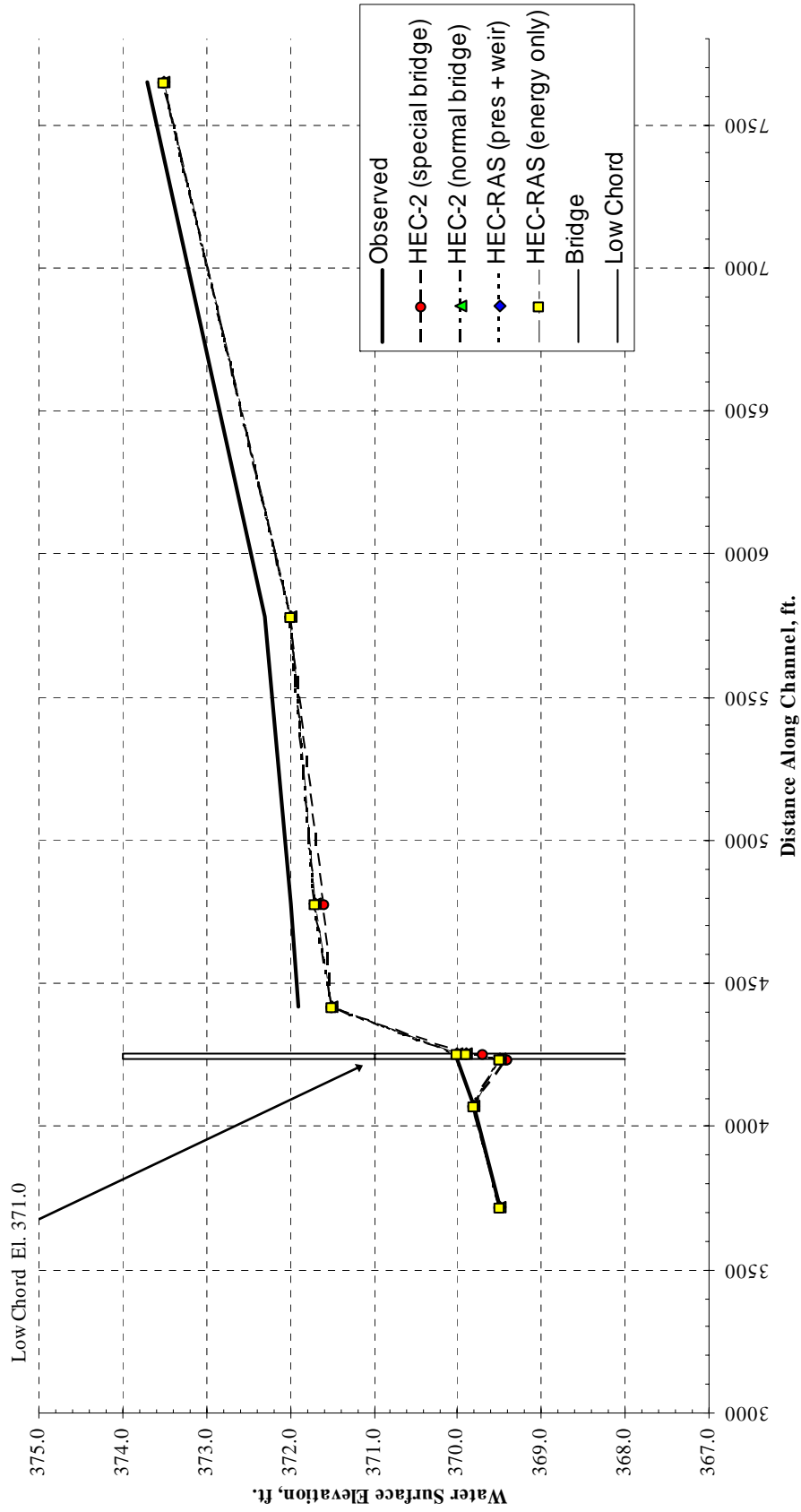



**YELLOW RIVER, ALABAMA Q = 6603 cfs**

Computed Results From:															
			HEC-2 (special bridge)				HEC-2 (normal bridge)				HEC-RAS (pressure & weir)		HEC-RAS (energy only)		
Channel Distance, ft	Section Minimum Elevation, ft	Observed WSEL, ft	Depth, ft	WSEL, ft	Absolute Error, ft	Relative Error Squared **	WSEL, ft	Absolute Error, ft	Relative Error Squared **	WSEL, ft	Absolute Error, ft	Relative Error Squared **	WSEL, ft	Absolute Error, ft	Relative Error Squared **
3 EX	224.8	235.7	11.0	235.7	0.0	0.0	235.7	0.0	0.0	235.7	0.0	0.0	235.7	0.0	0.0
3.1	223.5	236.0	12.5	236.6	0.6	2.32E-03	236.6	0.6	2.32E-03	236.7	0.7	3.15E-03	236.7	0.7	3.15E-03
BR	223.5	NA		NA			236.6			236.7			236.7		
BR	223.5	NA		NA			236.9			237.4			237.1		
3.4	223.5	237.3	13.8	237.2	-0.1	5.27E-05	237.0	-0.3	4.75E-04	237.4	0.1	5.27E-05	237.1	-0.2	2.11E-04
4 AP	227.1	237.3	10.2	237.7	0.4	1.55E-03	237.5	0.2	3.88E-04	237.9	0.6	3.49E-03	237.6	0.3	8.72E-04
5	227.8	238.1	10.3	238.2	0.1	9.37E-05	238.0	-0.1	9.37E-05	238.3	0.2	3.75E-04	238.1	0.0	0.00E+00
				Sum of Rel. Error Squared:				0.00033				0.0071		0.0042	
				Standard Error***:				0.032				0.029		0.042	

**EXPLANATION OF SYMBOLS:**

- EX Denotes the section downstream of the bridge where effective flow width is assumed to have expanded to the full floodplain width. In this study the distance to full expansion is assumed to be approximately equal to the transverse width of the bridge opening, unless otherwise noted.
- BR Denotes a section just inside the bridge.
- AP Denotes the section located upstream of the bridge a distance approximately equal to the transverse width of the bridge opening.
- NA Indicates that the value is not available from the data or the program output.
- \* Indicates that the observed water surface value is questionable either because there were very few values recorded on the atlas and/or because those that have been provided are not located within the active flow area
- \*\* Relative Error Squared is equal to the square of the absolute error divided by the depth: (Abs. Error / Depth)<sup>2</sup>.
- \*\*\* Standard Error is equal to the square root of the Relative Error Squared divided by the number of RES values summed: (Rel. Error Sq / n)<sup>0.5</sup>

**YELLOW RIVER Q = 6603 cfs**

