

# Operational Rules

USACE, Institute for Water Resources, Hydrologic Engineering Center





# Objective:

- To convince you that you can use Rules.



# Why Rules?



Rules Operate Gates and Pumps based on any mid-Simulation RAS Result (1D)

Including logic, math, and statistics.

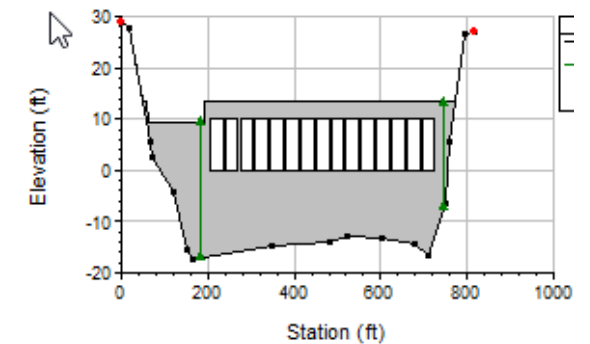
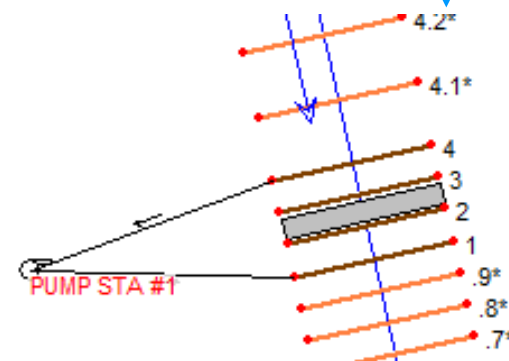
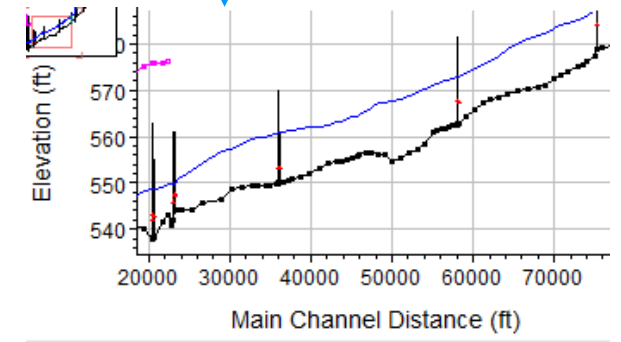
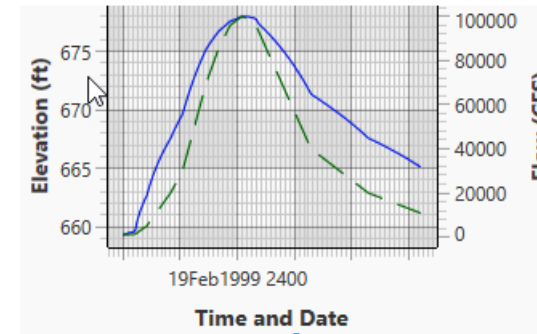



# How Rules Work



- Rules are a set of instructions for operating a hydraulic structure (eg gates)
- At the beginning of each time step, RAS evaluates Rules and changes hydraulic structure operations
- Elevation controlled gates can be thought of as a simple set of rules

Unsteady Flow Data - Unsteady Flow Hydrograph

File Options Help

Description: [ ] [Apply Data]

Boundary Conditions | Initial Conditions | Meteorological Data | Observed Data

Boundary Condition Types

Stage Hydrograph	Flow Hydrograph	Stage/Flow Hydr.	Rating Curve
Normal Depth	Lateral Inflow Hydr.	Uniform Lateral Inflow	Groundwater Interflow
T.S. Gate Openings	<b>Elev Controlled Gates</b>	Navigation Dams	IB Stage/Flow
Rules	Precipitation		

Add RS ... Add SA/2D Flow Area ...

Select Location in table

	River	Reach	RS
1	Nittany River	Weir Reach	60.
2	Nittany River	Weir Reach	41.
3	Nittany River	Weir Reach	36.

Elevation Controlled Gates

River: Nittany River Reach: Weir Reach RS: 41.75

Gate Group: Left Group

Reference: Based on upstream WS

Upstream WS Elevation Reference

Upstream WS elevation at which gate begins to open: [ ]

Upstream WS elevation at which gate begins to close: [ ]

Gate Opening Rate:(ft/min): [ ]

Gate Closing Rate:(ft/min): [ ]

Maximum Gate Opening: [ ]

Minimum Gate Opening: [ ]

Initial Gate Opening (Optional): [ ]

OK Cancel

# Elevation Controlled Gate Rule Example

**Elevation Controlled Gates**

River: Nittany River Reach: Weir Reach RS: 41.75

Gate Group:

Reference:

Upstream WS Elevation Reference

Upstream WS elevation at which gate begins to open:

Upstream WS elevation at which gate begins to close:

Gate Opening Rate:(ft/min):

Gate Closing Rate:(ft/min):

Maximum Gate Opening:

Minimum Gate Opening:

Initial Gate Opening (Optional):

In this example, the rules will operate the gates in the same manner as the Elevation Controlled Gate boundary type.

Gate Parameters				
Open Rate (ft/min)	Close Rate (ft/min)	Max Opening	Min Opening	Initial Opening
0.1	0.1	10	2	2

Summary of Variable Initializations:		
User Variable	Description	Initial Value
1		

Rule Operations	
row	Operation
1	'WSEL' = Cross Sections:WS Elevation(Nittany River,Weir Reach,41.76,Value at current time step)
2	If (WSEL > 6) Then
3	Gate.Opening(Left Group) = 10
4	Elseif (WSEL < 4) Then
5	Gate.Opening(Left Group) = 2
6	Else
7	Gate.Opening(Left Group) = [not set]
8	End If



# Rule Example for Elevation Controlled Gates



Operation Rules

Rule Based Operations

row	Operation
1	!
2	'WSEL' = Cross Sections:WS Elevation(Nittany River,Weir Reach,41.76
- 3	If ('WSEL' > 6) Then
4	Gate.Opening(Left Group) = 10
5	Elself ('WSEL' < 4) Then
6	Gate.Opening(Left Group) = 2
7	Else
8	Gate.Opening(Left Group) = [not set]
9	End If



# Rules



Boundary Conditions | Initial Conditions

**Boundary Condition Types**

Stage Hydrograph	Flow Hydrograph	Stage/Flow Hydr.
Normal Depth	Lateral Inflow Hydr.	Uniform Lateral Inflow
T.S. Gate Openings	Elev Controlled Gates	Navigation Dams
<b>Rules</b>		

**Add Boundary Condition Location**

Add RS ... Add Storage Area ... Add SA Connection ...

Select Location in table then select Boundary Condition Type

	River	Reach	RS	Boundary Condition
1	Missouri River	Missouri	879.01	Flow Hydrograph
2	Missouri River	Missouri	849.9	Lateral Inflow Hydr.
3	Missouri River	Missouri	811.065 IS	<b>Rules</b>
4	Missouri River	Missouri	810.901	Stage Hydrograph

Set initial gate parameters

**Rule Operations**

Description:

**Gate Parameters**

	Location	Open Rate (ft/min)	Close Rate (ft/min)	Max Opening	Min Opening	Initial Opening
1	Gates	0.5	0.5	30	0	1

**Summary of Variable Initializations:**

User Variable	Description	Initial Value
1		

**Rule Operations**

row	Operation
1	'Pool Stage' = Cross Sections:WS Elevation(Missouri River, Missouri, 811.076, Value at curren...
2	'RunTime' = Time:Hour of Simulation(Beginning of time step)
3	!
4	!
5	Structure.Total Flow (Desired) = 60000
6	!
7	! Start to fill after 11 total days of run time
8	If ('RunTime' > 246) And ('Pool Stage' < 1205) Then
9	Structure.Total Flow (Desired) = 5000
10	ElseIf ('RunTime' > 246) And ('Pool Stage' >= 1205) Then
11	Structure.Total Flow (Desired) = 30000
12	End If

Enter/Edit Rule Operations... OK Cancel

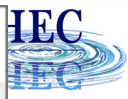

# Operation Rules

Rule Based Operations

Rule Font Size: 10  Bold Font

row	Operation	True	Fa...
-----	-----------	------	-------

Click on one of the 'Insert New Operations' buttons below to add an operation to this rule set

## Insert New Operation

- Comment
- New Variable
- Get Sim Value
- Set Operational Param
- Branch (If/Else)
- Math
- Table

## Current Selection Changes

- 
- 
- 
- 
- Enable
- Disable

Click on one of the 'Insert New Operations' buttons below to add an operation to this rule set

Insert New Operation

Comment

New Variable

Get Sim Value

Set Operational Param

Branch (If/Else)

Math

Table



# Rules

“HEC-RAS Output”  
WSE/Q/Time

Turn HEC-RAS Results  
into a Variable

Change Something  
in RAS

e.g. Open/Close a Gate

If/Then/Else  
And/Or

Programming  
Logic

Get Sim Value	Set Operational Param	Branch (If/Else)
---------------	-----------------------	------------------



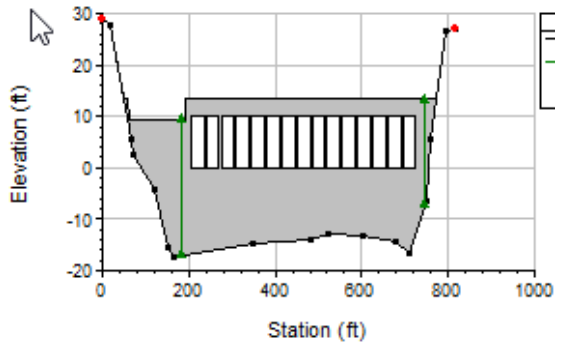
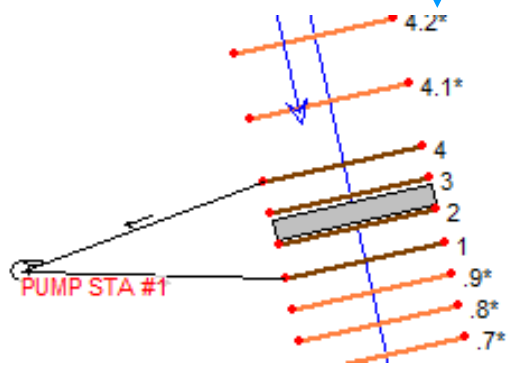
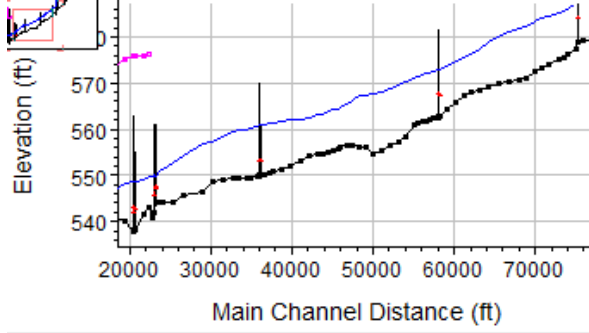
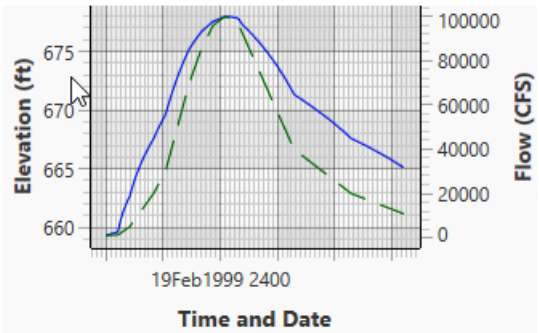

Get Sim Value

Set Operational Param

### Get Simulation Value

Assign Result

Existing Variable

New Variable

SAwse

- Cross Sections
- Inline Structures
- Lateral Structures
- Storage Areas
  - WS Elevation
  - Net Inflow
  - Total Inflow
  - Total Outflow
  - Area
  - Volume
- Storage Area Connections

### Insert New Operation

Comment    New Variable    **Get Sim Value**    Set Operational Param    Branch (If/Else)    Math    Table

### Set Operational Parameter (i.e. gate opening)

Structure.Total Flow (Fixed)

Structure.Total Flow (Desired)

Structure.Flow Additional

Structure.Flow Maximum

Structure.Flow Minimum

Structure.Total Gate Flow

Structure.Total Gate Flow Maximum

Structure.Total Gate Flow Minimum

=

Expression

Edit ... X

10

### Branching Operation (If/Else/ElseIf/Else/EndIf)

Branching Line Type:

If ( ) Then

If ( ) And/Or ( ) Then

ElseIf ( ) Then

ElseIf ( ) And/Or ( ) Then

Else

End If

Expression

Edit ... X

'SAwse'

< ▾

Expression

Edit ... X

5



# Get Simulation Value



Operation Rules

Rule Based Operations Rule Font Size: 10  Bold Font

row	Operation	True	Fa...
1	" =	2	2
2	! Rules Demo	3	3
3	'SAwse' = Storage Areas:WS Elevation(Storage Supply,Value at current time step)	4	4
4	'LSq' = Lateral Structures:Structure.Total Flow(Nittany River,Weir Reach,42.6,Value at current time step)	5	5
5	'InlineQ' = Inline Structures:Structure.Total Flow(Nittany River,Weir Reach,41.75,Value at current time step)	6	6
- 6	If ('SAwse' < 5) And ('LSq' < 0.2 * 'InlineQ') Then	7	8
7	Gate.Opening(Gate #1) = 10	10	10
8	Else	9	9
9	Gate.Opening(Gate #1) = 0	10	10
10	End If		0

Insert New Operation

Comment New Variable **Get Sim Value** Set Operational Param Branch (If/Else) Math Table

Current Selection Changes Enable Disable

Get Simulation Value

Assign Result

Existing Variable

New Variable

LSq

Simulation Variables

- Time
- Solution
- Cross Sections
- Inline Structures
- Lateral Structures
  - Structure.Total Flow
  - Structure.Stage (Fixed)**
  - Weir.Flow
  - Weir.Flow Maximum

Set Node Location

River: Nittany River

Reach: Weir Reach

RS: 42.6 LS

Value at current time step

(Simulation variables in bold are only available for the current structure)

Check Rule Set ... OK Cancel



# Set Operation



Operation Rules

Rule Based Operations Rule Font Size: 10  Bold Font

row	Operation	True	False
1	! Rules Demo	2	2
2	'SAwse' = Storage Areas:WS Elevation(Storage Supply,Value at current time step)	3	3
3	'LSq' = Lateral Structures:Structure.Total Flow(Nittany River,Weir Reach,42.6,Value at current time step)	4	4
4	'InlineQ' = Inline Structures:Structure.Total Flow(Nittany River,Weir Reach,41.75,Value at current time step)	5	5
- 5	If ('SAwse' < 5) And ('LSq' < 0.2 * 'InlineQ') Then	6	7
6	Gate.Opening(Gate #1) = 10	9	9
7	Else	8	8
8	Gate.Opening(Gate #1) = 0	9	9
9	End If	0	0

Insert New Operation

Comment New Variable Get Sim Value **Set Operational Param** Branch (If/Else) Math Table

Current Selection Changes Enable Disable

Set Operational Parameter (i.e. gate opening)

Weir.Minimum Elev for Weir Flow  
Weir.C Simple (Positive)  
Weir.C Simple (Negative)  
Gate.Flow (Fixed)  
Gate.Flow (Desired)  
Gate.Flow Maximum  
Gate.Flow Minimum  
**Gate.Opening**

=

Expression  
Edit ...   
10

Select Gate Group  
Gate: Gate #1

Gate opening height for the gate group. Check Rule Set ... OK Cancel



# Variable Selection



Operation Rules

Rule Based Operations Rule Font Size: 10  Bold Font

row	Operation
1	! Rule Demo for Class
2	'SAwatersurface' = Storage Areas:WS Elevation(Storage Supply, Value at current time step)
- 3	If ([not set] [not set]) Then

Edit Rule Expression

( Exponent Coef \* Exponent Variable )

Coefficient \* Variable + Constant

Current Expression: SAwatersurface

Clear Expression OK Cancel

Branching Operation (If/Else/ElseIf/Else/Endif)

Branching Line Type:

- If ( ) Then
- If ( ) And/Or ( ) Then
- ElseIf ( ) Then
- ElseIf ( ) And/Or ( ) Then
- Else
- End If

Expression Edit ... [not set]

Expression Edit ... [not set]



# Rules

```
2 'Pool Stage' = Cross Sections:WS Elevation(Missouri River, Missouri, 811.076
3 'RunTime' = Time:Hour of Simulation(Beginning of time step)
4 !
5 !
6 Structure.Total Flow (Desired) = 60000
7 !
8 ! Start to fill after 11 total days of run time
9 If ('RunTime' > 246) And ('Pool Stage' < 1205) Then
10     Structure.Total Flow (Desired) = 5000
11 Elseif ('RunTime' > 246) And ('Pool Stage' >= 1205) Then
12     Structure.Total Flow (Desired) = 30000
13 End If
```

Get Sim Value

Set Operational Param

Comment

Branch (If/Else)



# Rule Expression



36 ! Allowable diversion is based on the total flow for the previous 24 hour flow.  
 37 ! Flow into Green reservoir is assumed to equal flow out of the resevoir. (Over the long term).  
 38 ! Add the 24 hour volume at Green Dam and Canal Dam. Divide by 86400 seconds to get prior 24 ...  
 39  
 40  
 41  
 42  
 43  
 44  
 45  
 46  
 47  
 48 ! Flow too low. NO diversion allowed.  
 49 'Canal Dam Flow Diversion' = 0  
 50 !  
 51 Elself ('HR 24hour ave Flow' < 150) Then  
 52 ! Allowable diversion is 10 percent of prior days flow.  
 53 'Canal Dam Flow Diversion' = 0.1 \* 'HR 24hour ave Flow'  
 54 !  
 55 Elself ('HR 24hour ave Flow' < 215) Then  
 56 ! 10% to 30% (sliding scale).  
 57 'Canal Dam Flow Diversion' = [ (('HR 24hour ave Flow' - 150) \* (49.5)) / (65) ] + (15)  
 58 !  
 59 Elself ('HR 24hour ave Flow' < 1001) Then  
 60 ! Allowable diversion is 30 percent of prior days flow.

**Edit Rule Expression**

( Exponent Coef \* Exponent Variable )

Coefficient \* Variable + Constant

0.1 \* HR 24hour ave Flow

Current Expression: 0.1 \* 'HR 24hour ave Flow'

Clear Expression OK Cancel

Insert New Operation

Comment New Variable Get Sim Value Set Operational Param Branch (If/Else) Math Table

Current Selection Changes

Math Operation

Assign Result

Existing Variable

New Variable

Canal Dam Flow Diversion

Expression Edit X

0.1 \* HR

Expression Edit... X

[not set]

Expression Edit... X

[not set]

Expression Edit... X

[not set]



# Lookup Table for Flow Diversion



Operation Rules

Rule Based Operations Rule Font Size: 12 Bold Font

row	Operation
1	! Get the Hour of the Day
2	'Hour of Day' = Time:Hour of Day
3	!
4	! Get the average flow at the dam
5	! Average flow over an hour is us
6	'Flow at Inline Weir' = Inline Struct
7	!
8	! Based on both the Flow and the
9	! Use a 2-way table to look up the flow to divert.
10	'Flow to Divert' = Table Lookup(Inline Flow, Hour, Interpolate value)
11	!
12	! Set the amount of flow to divert.
13	Structure.Total Flow (Fixed) = 'Flow to Divert'

Rule Table

Table Data

		1	2	3	4	5	6
	Inline Flow\Hour	0	6	12	18	24	
1	0	0	0	0	0	0	
2	10000	500	600	1000	900	500	
3	20000	1000	1400	2000	1700	1000	
4							
5							

Insert New Operation

Comment New Variable Get Sim Value Set Operational Param Branch (If/Else) Math Table

Current Selection Changes

Table Lookup

Assign Result

Existing Variable

New Variable

Flow to Divert

One Dimensional Table (Single Interpolation)

Two Dimensional Table (2-way Interpolation)

Expression

Flow at

Hour of Day

Argument Name: Inline Flow

Argument Name: Hour

Interpolate value

Enter/Edit Table Data ...

Check Rule Set ...

OK Cancel



# Rule Hacks



## “Dummy” SA and/or Structure

Unsteady Flow Data - Unsteady Flow Hydrograph

File Options Help

Description: [ ] [Apply Data]

Boundary Conditions | Initial Conditions | Meteorological Data | Observed Data

**Boundary Condition Types**

Stage Hydrograph	Flow Hydrograph	Stage/Flow Hydr.	Rating Curve
Normal Depth	Lateral Inflow Hydr.	Uniform Lateral Inflow	Groundwater Interflow
T.S. Gate Openings	Elev Controlled Gates	Navigation Dams	IB Stage/Flow
Rules	Precipitation		

**Add Boundary Condition Location**

Add RS ... Add SA/2D Flow Area ... Add Conn ... Add Pump Sta ... Add Pipe Node ...

Select Location in table then select Boundary Condition Type

River	Reach	RS	Boundary Condition
1 Nittany River	Weir Reach	60.1	Flow Hydrograph
2 Nittany River	Weir Reach	41.75 IS	Rules
3 Nittany River	Weir Reach	36.85	Normal Depth

**Storage/2D Flow Areas**

Storage/2D Flow Areas	Boundary Condition
1 Dummy #1	Lateral Inflow Hydr.

**SA/2D Area Conns**

SA/2D Area Conns	Boundary Condition
1 Dummy Connection	T.S. Gate Openings

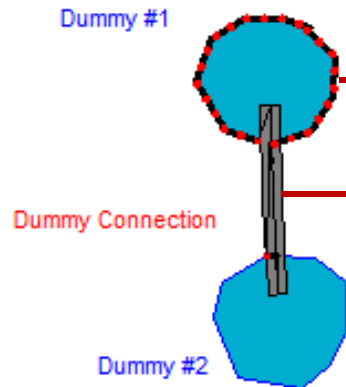
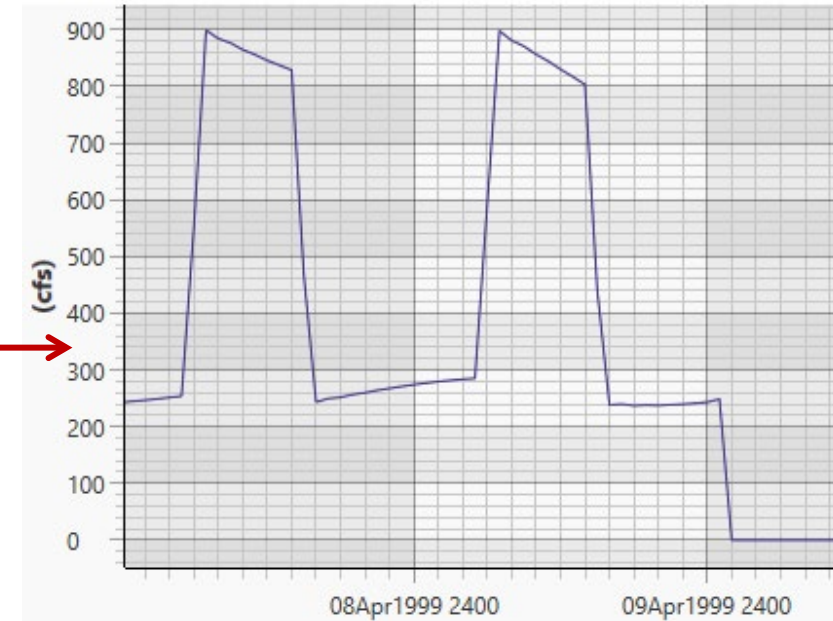



# Rule Hacks



## Structure.Total Flow.(Desired)

```
2 'Pool Stage' = Cross Sections:WS Elevation(Missouri River, Missouri, 811.076
3 'RunTime' = Time:Hour of Simulation(Beginning of time step)
4 !
5 !
6 Structure.Total Flow (Desired) = 60000
7 !
8 ! Start to fill after 11 total days of run time
9 If ('RunTime' > 246) And ('Pool Stage' < 1205) Then
10     Structure.Total Flow (Desired) = 5000
11 Elseif ('RunTime' > 246) And ('Pool Stage' >= 1205) Then
12     Structure.Total Flow (Desired) = 30000
13 End If
```

Get Sim Value

Set Operational Param

Comment

Branch (If/Else)

Set Operational Parameter (i.e. gate opening)

Structure.Total Flow (Fixed)  
Structure.Total Flow (Desired)  
Structure.Flow Additional  
Structure.Flow Maximum  
Structure.Flow Minimum  
Structure.Total Gate Flow  
Structure.Total Gate Flow Maximum  
Structure.Total Gate Flow Minimum

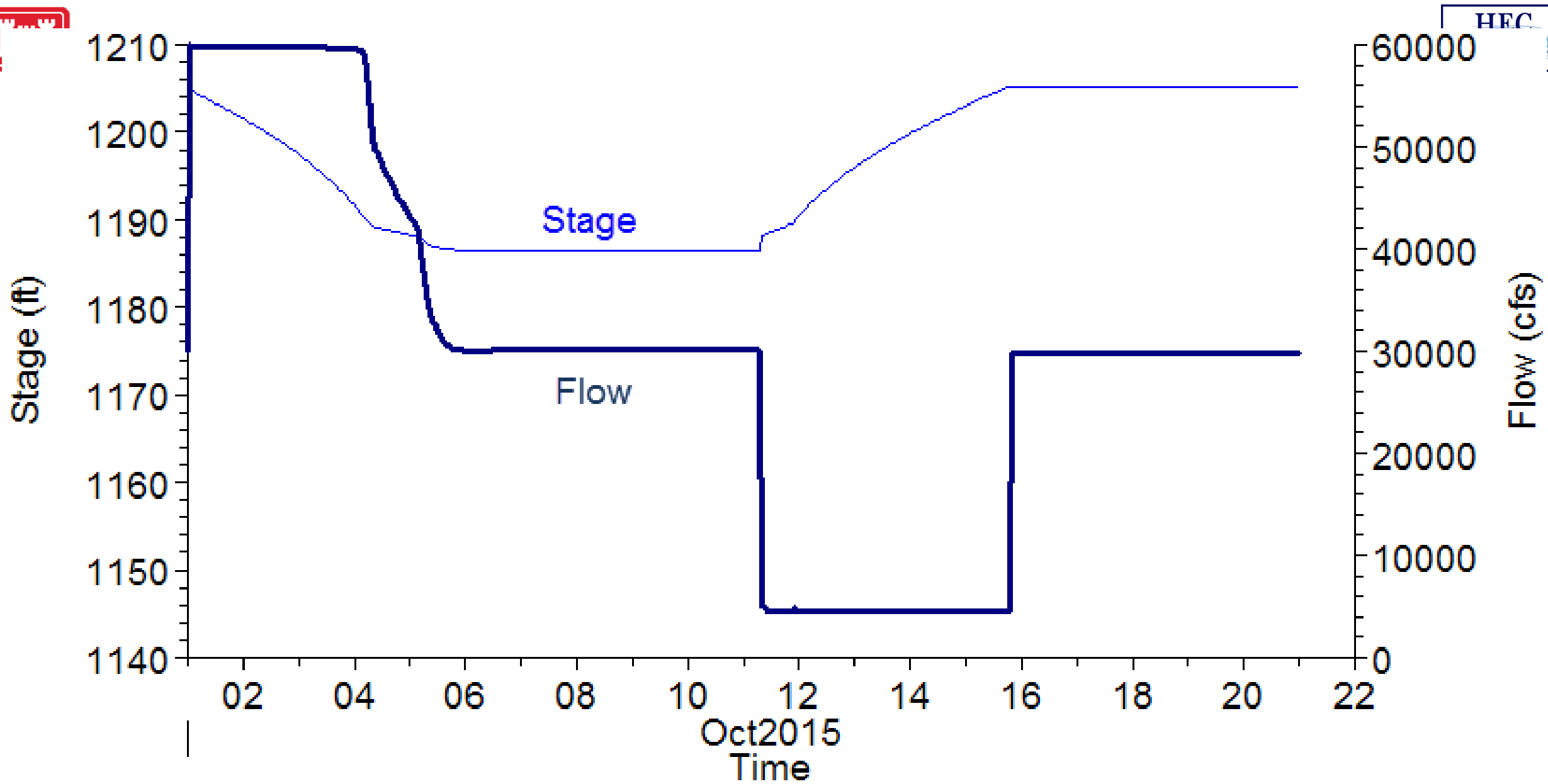

-The relatively simple rule set in the previous slide generated this draining/flushing/refilling hydrograph.

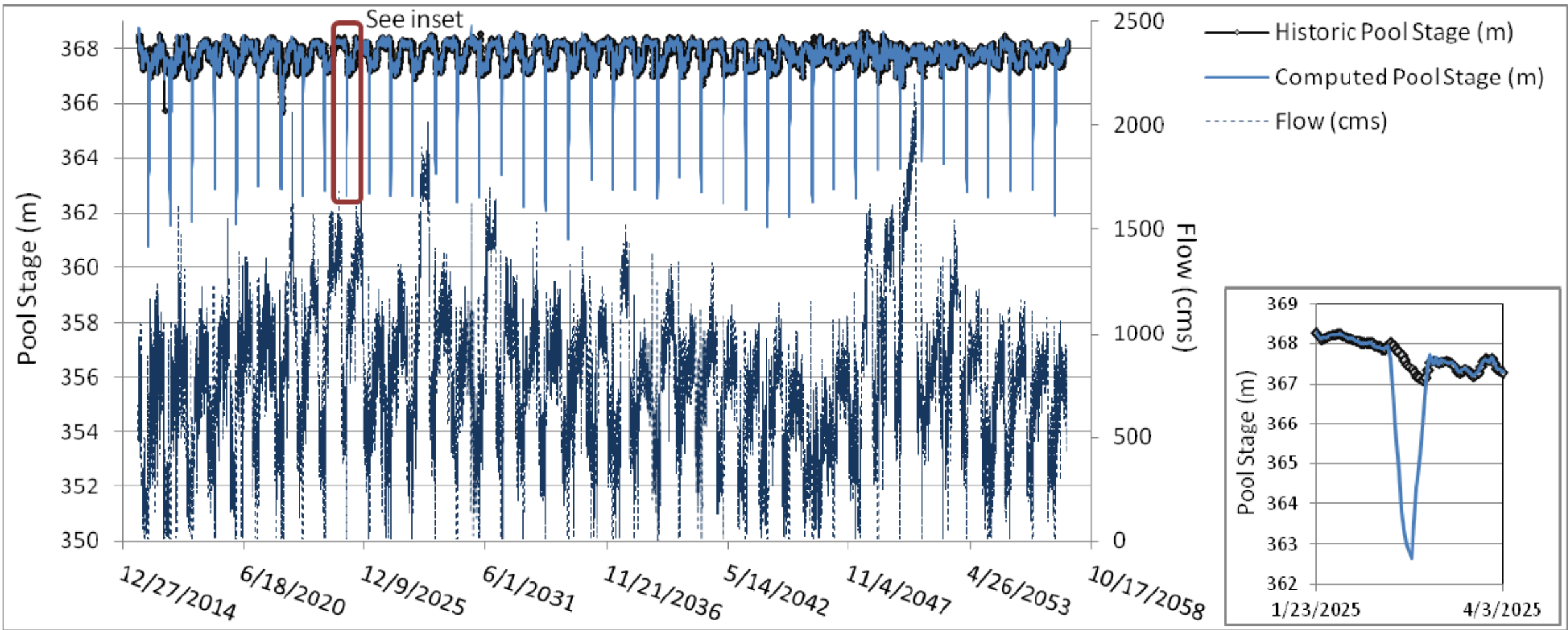
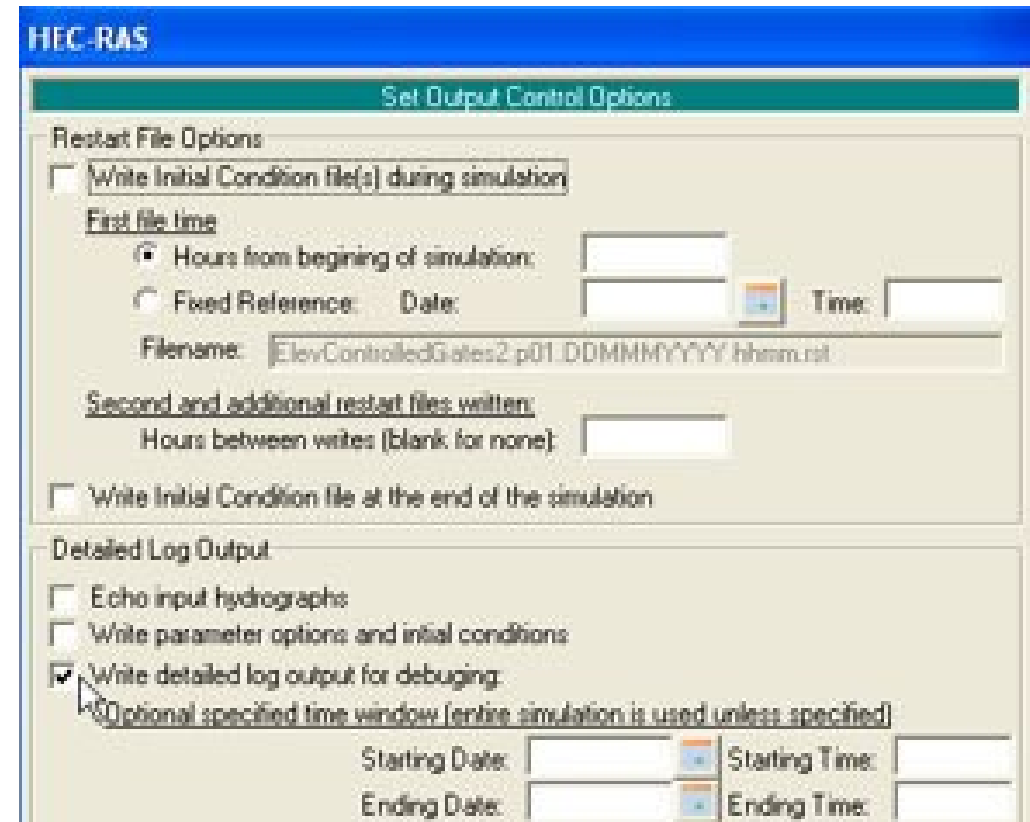
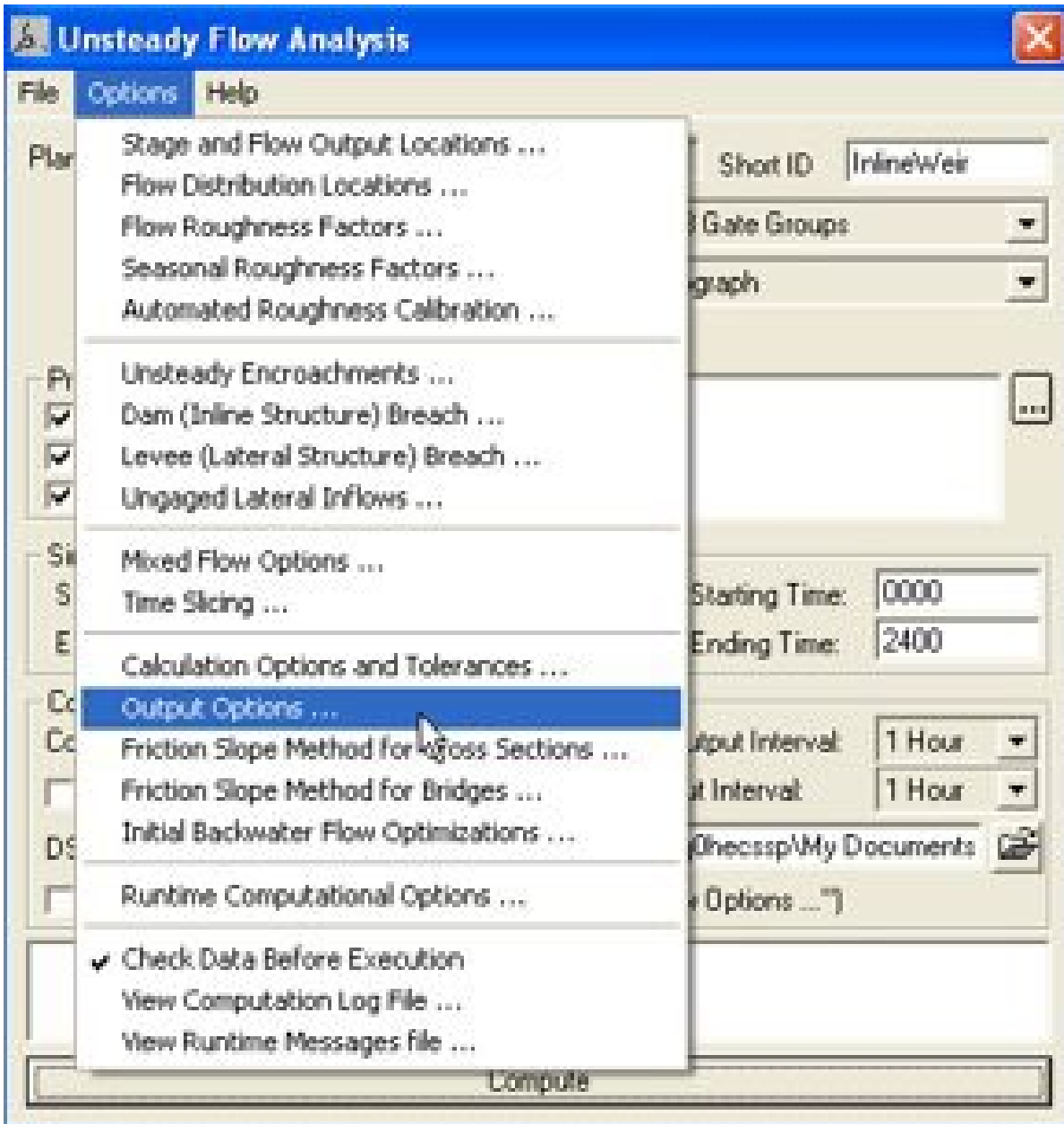

Figure 5: Fifty-Seven year period of record simulation starting with the 2011 geometry, which uses operational rules to maintain the historic water surface elevation coupled with the historic flows, but introduces an 850 cms flushing event every spring based on calendar and physical constraints.

Gibson, S. and Boyd, P. (2014) “Modeling Long Term Alternatives for Sustainable Sediment Management Using Operational Sediment Transport Rules,” *Reservoir Sedimentation* –Scheiss et al. (eds), 229-236.



# Turn on Detailed Log





# View Detailed Log



```

ElevControlledGates2.bco01 - Notepad
File Edit Format View Help

      Nittany River      Weir Reach
Riv. Station      Z      Q      V      Riv. Station      Z      Q      V
  60.1      9.45      30712.      3.47
  41.76      6.01      25499.      2.23
  41.74      -2.14      25499.      3.74
  36.85      -4.46      19493.      2.18

      Inline weirs
RIVER      STATION      QTOTAL      QWEIR      QGATE      SUBMERGENCE      QPIPING
Nittany River      41.75      25499.31      0.00      25578.56      0.000      0.00
Left Group      GO= 6.00      Q= 25499.31

Hydrographs written at      21.00hours.

***      Start of New Time Step      ***

      Rule Set for Nittany River Weir Reach 41.75
0001      WSEL = 6.010225
0002      True      6.010225 > 6.
0003      SET      Gate.Opening Left Group = 10.

      solving for time window =      21.00000      to      21.08333

```





# Rule Hacks



## Read the Manual !!!

HEC-RAS User's Manual

HEC Home RAS Docs Downloads 6.2

HEC-RAS User's Manual / Advanced Features for Unsteady Flow Routing / **User Defined Rules for Hydraulic Structures and Pumps** PDF

### User Defined Rules for Hydraulic Structures and Pumps

The operating procedures for determining and controlling the releases from reservoirs and other types of hydraulic structures can be quite complex. HEC-RAS allows flexibility in modeling and controlling the operations of hydraulic structures through the use of rules (Figure 14-40).

River	Reach	RS	Boundary Condition
1	Nittany River Weir Reach	60.1	Flow Hydrograph
2	Nittany River Weir Reach	41.75 IS	Rules
3	Nittany River Weir Reach	36.85	Normal Depth

Initial internal water surface elevations set

<https://www.hec.usace.army.mil/confluence/rasdocs/rasum/latest/advanced-features-for-unsteady-flow-routing/user-defined-rules-for-hydraulic-structures-and-pumps>



# Examples



# From Elev to Rules



**Elevation Controlled Gates**

River: Nittany River Reach: Weir Reach RS: 41.75

Gate Group:

Reference:

Upstream WS Elevation Reference

Upstream WS elevation at which gate begins to open:

Upstream WS elevation at which gate begins to close:

Gate Opening Rate (ft/min):

Gate Closing Rate (ft/min):

Maximum Gate Opening:

Minimum Gate Opening:

Initial Gate Opening:

**Unsteady Flow Data - Unsteady Flow Hydrograph**

File Options Help

Boundary Conditions | Initial Conditions

**Boundary Condition Types**

Stage Hydrograph	Flow Hydrograph	Stage/Flow Hydro...	
Normal Depth	Lateral Inflow Hydr...	Uniform Lateral Inflow	Gr...
T.S. Gate Openings	Elev Controlled Gates	Navigation Dams	
<b>Rules</b>			

**Add Boundary Condition Location**

**Select Location in table then select Boundary Condition Type**

	River	Reach	RS	Boundary Condition
1	Nittany River	Weir Reach	60.1	Flow Hydrograph
2	Nittany River	Weir Reach	41.75 IS	Elev Controlled Gates
3	Nittany River	Weir Reach	36.85	Rating Curve

**RAS**

Boundary at: "River: Nittany River Reach: Weir Reach RS: 41.75" currently has a bou...

Do you want to overwrite the existing data with a new "Rules" boundary condition?



# Gate Parameters



**Rule Operations**

Description: Duplicate behavior of elevation controlled gate.

**Gate Parameters**

	Location	Open Rate (ft/min)	Close Rate (ft/min)	Max Opening	Min Opening	Initial Opening
1	Drop Gates	0.1	0.1	10	2	2

**Summary of Variable Initializations:**

User Variable	Description	Initial Value
1		

**Rule Operations**

row	Operation	True	False

Enter/Edit Rule Operations... OK Cancel



# Get Simulation Value



Operation Rules

Rule Based Operations Rule Font Size: 14 Bold Font

row	Operation
1	" =

Insert New Operation

Comment New Variable **Get Sim Value** Set Operational Param Branch (If/Else) Math Table

Current Selection Changes

Value at current time step

Get Simulation Value

Assign Result

Existing Variable

New Variable

Simulation Variables

- Time
- Solution
- Cross Sections
- Inline Structures
- Lateral Structures
- Storage Areas
- Storage Area Connections
- Pump Stations

[Simulation variables in bold are only available for the current structure]

Check Rule Set ... OK Cancel



# Get WSEL



**Operation Rules**

Rule Based Operations Rule Font Size: 14 Bold Font

row	Operation
1	'WSEL' = Cross Sections:WS Elevation(Nittany River,Weir Reach,60.1,Value at cur...

Insert New Operation: Comment, New Variable, Get Sim Value, Set Operational Param, Branch (If/Else), Math, Table

Current Selection Changes: [Icons] Enable Disable

Get Simulation Value

Assign Result:  
 Existing Variable  
 New Variable  
WSEL

Simulation Variables:  
Time  
Solution  
Cross Sections  
  WS Elevation  
  Flow  
  WS Change  
  Flow Change  
  WS Error  
  Flow Error

Set Node Location:  
River: Nittany River  
Reach: Weir Reach  
RS: 60.1

Value at current time step

(Simulation) [List of values: 42.9, 42, 41.78, 41.76, 41.74, 41.70, 41.5, 40.8]

only available for the current structure

Check Rule Set ... OK Cancel



# If/Then



Operation Rules

Rule Based Operations Rule Font Size:

row	Operation
1	'WSEL' = Cross Sections:WS Elevation(Nittany River,Weir Reach,41.76,)
- 2	If ([not set] [not set]) Then

**Edit Rule Expression**

( Exponent Coef \* Exponent Variable )

Coefficient \* Variable + Constant

Current Expression: WSEL

Clear Expression OK Cancel

Insert New Operation

Comment New Variable Get Sim Value Set Operational Param Branch (If/Else) Math Table

Branching Operation (If/Else/Elseif/Else/Endif)

Branching Line Type:

- If ( ) Then
- If ( ) And/Or ( ) Then
- Elseif ( ) Then
- Elseif ( ) And/Or ( ) Then
- Else
- End If

Expression [not set] Expression [not set]



# Setting Expression



Operation Rules

Rule Based Operations Rule Font Size: 14 [v] [x] Bo

row	Operation
1	'WSEL' = Cross Sections:WS Elevation(Nittany River,Weir Reach,41.76,Value at c
- 2	If ('WSEL' > 6) Then

Edit Rule Expression

( Exponent Coef \* Exponent Variable )

Coefficient \* Variable + Constant

Current Expression: 6

Clear Expression OK Cancel

Insert New Operation

Comment New Variable Get Sim Value Set Operational Param Branch (If/Else) Math Table

Current Selection Changes [x] [x] [x] [x] Enable

Branching Operation (If/Else/Elseif/Else/EndIf)

Branching Line Type:

- If ( ) Then
- If ( ) And/Or ( ) Then
- Elseif ( ) Then
- Elseif ( ) And/Or ( ) Then
- Else
- End If

Expression: 'WSEL' > Expression: 6



# Set Gate Opening



Operation Rules

Rule Based Operations Rule Font Size: 14 Bold Font

row	Operation
1	'WSEL' = Cross Sections:WS Elevation(Nittany River,Weir Reach,41.76,Value at cu...
- 2	If ('WSEL' > 6) Then
3	Gate.Opening(Drop Gates) = 10

Edit Rule Expression

( Exponent Coef \* Exponent Variable )

Coefficient \* Variable + Constant

Current Expression: 10

Clear Expression OK Cancel

Insert New Operation

Comment New Variable Get Sim Value Set Operational Param Branch (If/Else) Math Table Enable Disable

Set Operational Parameter (i.e. gate opening)

Gate.Flow (Desired)  
Gate.Flow Maximum  
Gate.Flow Minimum  
Gate.Opening  
Gate.Opening (target position)  
Gate.Submergence  
Gate.Opening Rate  
Gate.Closing Rate  
Gate.Coefficient.Discharge

Select Gate Group

Gate: Drop Gates

Expression = 10

Gate opening height for the gate group. Check Rule Set ... OK Cancel



# End If



Operation Rules

Rule Based Operations Rule Font Size: 14 Bold Font

row	Operation
1	'WSEL' = Cross Sections:WS Elevation(Nittany River,Weir Reach,41.76,Value at cu...
- 2	If ('WSEL' > 6) Then
3	Gate.Opening(Drop Gates) = 10
4	End If

Insert New Operation

Comment New Variable Get Sim Value Set Operational Param Branch (If/Else) Math Table

Current Selection Changes

Branching Operation (If/Else/Elseif/Else/Endif)

Branching Line Type:

- If ( ) Then
- If ( ) And/Or ( ) Then
- Elseif ( ) Then
- Elseif ( ) And/Or ( ) Then
- Else
- End If



# Copy and Paste



row	Operation
1	'WSEL' = Cross Sections:WS Elevation(Nittany River,Weir Reach,41.76,Value at c...
2	If ('WSEL' > 6) Then
3	Gate.Opening(Drop Gates) = 10
4	End If

Insert New Operation

Comment    New Variable    Get Sim Value    Set Operational Param    Branch (If/Else)    Math    Table

Current Selection Changes

   Enable    Disable

Copy current selected rule(s) to the clipboard

row	Operation
1	'WSEL' = Cross Sections:WS Elevation(Nittany River,Weir Reach,41.76,Value at cu...
2	If ('WSEL' > 6) Then
3	Gate.Opening(Drop Gates) = 10
4	End If
5	If ('WSEL' > 6) Then
6	Gate.Opening(Drop Gates) = 10
7	End If

Insert New Operation

Comment    New Variable    Get Sim Value    Set Operational Param    Branch (If/Else)    Math    Table

Current Selection Changes

   Enable    Disable

Paste the rules in the clipboard into the current rule set



# Edit Values



row	Operation
1	'WSEL' = Cross Sections:WS Elevation(Nittany River,Weir Reach,41.76,Value at current time step)
- 2	If ('WSEL' > 6) Then
3	Gate.Opening(Drop Gates) = 10
4	End If
- 5	If ('WSEL' < 4) Then
6	Gate.Opening(Drop Gates) = 10
7	End If

Insert New Operation  
Comment    New Variable    Get Sim Value    Set Operational Param

Branching Operation (If/Else/Elseif/Else/EndIf)  
Branching Line Type:  
 If ( ) Then  
 If ( ) And/Or ( ) Then  
 Elseif ( ) Then  
 Elseif ( ) And/Or ( ) Then

Expression: 'WSEL'    Expression: 4

Edit Rule Expression

( Exponent Coef \* Exponent Variable )

Coefficient \* Variable + Constant

Current Expression: 4

Clear Expression    OK    Cancel

row	Operation
1	'WSEL' = Cross Sections:WS Elevation(Nittany River,Weir Reach,41.76,Value at current time step)
- 2	If ('WSEL' > 6) Then
3	Gate.Opening(Drop Gates) = 10
4	End If
- 5	If ('WSEL' < 4) Then
6	Gate.Opening(Drop Gates) = 2
7	End If

Insert New Operation  
Comment    New Variable    Get Sim Value    Set Operational Param

Branching Operation (If/Else/Elseif/Else/EndIf)  
Branching Line Type:  
 If ( ) Then  
 If ( ) And/Or ( ) Then  
 Elseif ( ) Then  
 Elseif ( ) And/Or ( ) Then

Expression: 'WSEL'    Expression: 4

Edit Rule Expression

( Exponent Coef \* Exponent Variable )

Coefficient \* Variable + Constant

Current Expression: 2

Clear Expression    OK    Cancel



# Check Rule Set



Operation Rules

Rule Based Operations Rule Font Size: 12 Bold Font

row	Operation
1	'WSEL' = Cross Sections:WS Elevation(Nittany River,Weir Reach,41.76,Value at current time step)
- 2	If ('WSEL' > 6) Then
3	Gate.Opening(Drop Gates) = 10
4	End If
- 5	If ('WSEL' < 4) Then
6	Gate.Opening(Drop Gates) = 2
7	End If

Insert New Operation

Comment New Variable Get Sim Value Set Operational Param Branch (If/Else) Math Table

Current Selection Changes

Get Simulation Value

Assign Result

Existing Variable

New Variable

WSEL

Simulation Variables

- Time
- Solution
- Cross Sections
  - WS Elevation**
  - Flow
  - WS Change
  - Flow Change
  - WS Error
  - Flow Error
- Inline Structures

Set Node Location

River: Nittany River

Reach: Weir Reach

RS: 41.76

Value at current time step

**RAS**

No inconsistencies were found in the current rule set

OK

(Simulation variables in bold are only available for the current structure)

Gate opening height for the gate group.

Check Rule Set... OK Cancel



# Switch to “ Elself ”



Operation Rules

Rule Based Operations Rule Font Size: 14 Bold Font

row	Operation
1	'WSELatDam' = Cross Sections:WS Elevation(Nittany River,Weir Reach,41.76,Val...
- 2	If ('WSELatDam' > 6) Then
3	Gate.Opening(Left Group) = 10
4	Elself ('WSELatDam' < 4) Then
5	Gate.Opening(Left Group) = 2
6	End If

Insert New Operation

Comment New Variable Get Sim Value Set Operational Param Branch (If/Else) Math Table

Current Selection Changes

Branching Operation (If/Else/Elself/Else/Endif)

Branching Line Type:

- If ( ) Then
- If ( ) And/Or ( ) Then
- Elself ( ) Then
- Elself ( ) And/Or ( ) Then
- Else
- End If

Expression

WSELatDam' < 4

Gate opening height for the gate group. Check Rule Set ... OK Cancel



# Not Set



row	Operation
- 2	If ('WSELatDam' > 6) Then
3	Gate.Opening(Left Group) = 10
4	Elseif ('WSELatDam' < 4) Then
5	Gate.Opening(Left Group) = 2
6	Else
7	Gate.Opening(Left Group) = [not set]
8	End If

Insert New Operation

Comment    New Variable    Get Sim Value    Set Operat...

Set Operational Parameter (i.e. gate opening)

Weir.C Simple (Positive)  
Weir.C Simple (Negative)  
Weir.Submergence  
Gate.Flow  
Gate.Flow (Fixed)  
Gate.Flow (Desired)  
Gate.Flow Maximum  
Gate.Flow Minimum  
**Gate.Opening**

Expression = [not set]

Select Gate Group  
Gate: Left Group

Edit Rule Expression

( Exponent Coef \* Exponent Variable )

Coefficient \* Variable + Constant

Current Expression: [not set]

Clear Expression    OK    Cancel



# Canal Data set Example



The screenshot shows the HEC-RAS software interface. The main window is titled 'Edit and/or create inline structures'. It features a toolbar with icons for 'River Reach', 'Storage Pond', 'S.A. Con.', 'Pump Station', 'PI', and a globe icon. The 'Description' field is empty, and the 'Pilot WS' is set to 'Inoned'. The left sidebar contains a vertical menu with icons for 'Canal', 'Cross Section', 'Brid/Cul', 'Inline Structure', 'Lateral Structure', 'Storage Pond', 'Storage Pond Con.', 'Pump Station', 'HTab Frame', and 'View Picture'. The main workspace displays a plan view of a canal with numerous elevation markers (e.g., 600036, 600040, 600044, 600048, 600052, 600056, 600060, 600064, 600068, 600072, 600076, 600080, 600084, 600088, 600092, 600096, 600100, 600104, 600108, 600112, 600116, 600120, 600124, 600128, 600132, 600136, 600140) and a central structure. A pop-up window titled 'Inline Structure Data - Green River with Diversion' is open, showing a cross-section graph of the canal structure. The graph plots 'Elevation (ft)' on the y-axis (0 to 30) against 'Station (ft)' on the x-axis (0 to 140). The structure is a trapezoidal canal with a central section containing two rectangular openings. The graph is titled 'Water supply diversion into canal' and 'Plan: Advanced Rule example: 5/26/2013'. The 'Legend' indicates 'Ground' (black dot) and 'Bank Sta.' (red dot). The 'River' is set to 'Green River', 'Reach' is '1', and 'River Sta.' is '73.3'. The 'Junction XS' is '73.75' and 'Upstream channel length' is '85 (ft)'. The 'Description' field is empty, and the 'Pilot Flow' is '0'. The 'All Culverts' are set to 'No Flap Gates'. The 'Cross Section' is 'Culvert'. The 'Outlet' is 'To'. The 'Legend' is 'Ground' and 'Bank Sta.'. The 'Select the river for inline structure editing' message is displayed at the bottom of the pop-up window.



# Cumulate Volumes



row	Operation
1	! Create user variables for storing volumes.
2	!
3	Real 'Green Dam Vol since midnight' (Initial Value = 0)
4	Real 'Canal Dam Vol since midnight' (Initial Value = 0)
5	Real 'Canal Dam Vol Diversion'
6	!
7	! Get time step and flows and then compute volumes (do this every time step).
8	!
9	! Get the current time step.
10	'Time Step hours' = Solution:Time Step(Value at current time step)
11	!
12	! Compute the time step in seconds.
13	'Time Step seconds' = [(3600 * 'Time Step hours' [not set]) [not set]] [not set]
14	!
15	! Get current flow at Green Dam and Canal Dam.
16	'Green Dam Flow' = Inline Structures:Structure.Total Flow(Green,2,600042,Value at current time step)
17	'Canal Dam Flow' = Inline Structures:Structure.Total Flow(Diversion Canal,1,73.3,Value at current time step)
18	!
19	! Add in the new volume (add the new volume--flow*time-- to the current volume).
20	'Green Dam Vol since midnight' = (('Green Dam Flow' * ('Time Step seconds')) + ('Green Dam Vol since midnight'))
21	'Canal Dam Vol since midnight' = (('Canal Dam Flow' * ('Time Step seconds')) + ('Canal Dam Vol since midnight'))
22	!
23	! Check to see if it is midnight.
24	!
25	! Get Day of Month for the beginning and end of the time step.
26	'Day Beg time step' = Time:Day of Month(Beginning of time step)
27	'Day End time step' = Time:Day of Month(End of time step)
28	!
29	! If time is midnight then determine next days diversion; if any.
30	!
- 31	If ('Day Beg time step' <> 'Day End time step') Then



# Compute Volume at Midnight



```
31 If ('Day Beg time step' <> 'Day End time step') Then
32 |
33 | ! Time is midnight. Following operations are only performed once a day.
34 | ! Compute allowable flow through Canal Dam and set gate openings.
35 |
36 | ! Allowable diversion is based on the total flow for the previous 24 hour flow.
37 | ! Flow into Green reservoir is assumed to equal flow out of the resevoir. (Over the long term).
38 | ! Add the 24 hour volume at Green Dam and Canal Dam. Divide by 86400 seconds to get prior 24 hour flow (in cfs).
39 | 'HR 24hour ave Flow' = (('Green Dam Vol since midnight') + ('Canal Dam Vol since midnight')) / (86400)
40 |
41 | ! Reset the volumes to zero (for the next days accounting).
42 | 'Green Dam Vol since midnight' = 0
43 | 'Canal Dam Vol since midnight' = 0
44 |
45 | ! Determine allowable diversion based on prior days average flow.
46 |
47 | If ('HR 24hour ave Flow' < 100) Then
48 | | ! Flow too low. No diversion allowed.
49 | | 'Canal Dam Flow Diversion' = 0
50 | |
51 | | Elseif ('HR 24hour ave Flow' < 150) Then
52 | | | ! Allowable diversion is 10 percent of prior days flow.
53 | | | 'Canal Dam Flow Diversion' = 0.1 * 'HR 24hour ave Flow'
54 | | |
55 | | | Elseif ('HR 24hour ave Flow' < 215) Then
56 | | | | ! 10% to 30% (sliding scale).
57 | | | | 'Canal Dam Flow Diversion' = [ (('HR 24hour ave Flow' - 150) * (49.5)) / (65) ] + (15)
58 | | | |
59 | | | | Elseif ('HR 24hour ave Flow' < 1001) Then
60 | | | | | ! Allowable diversion is 30 percent of prior days flow.
61 | | | | | 'Canal Dam Flow Diversion' = 0.3 * 'HR 24hour ave Flow'
```



# Sliding Scale Diversion



Operation Rules

Rule Based Operations Rule Font Size: 12 Bold Font

row	Operation
54	!
55	Elself ('HR 24hour ave Flow' < 215) Then
56	! 10% to 30% (sliding scale).
57	'Canal Dam Flow Diversion' = [ (('HR 24hour ave Flow' - 150) * (49.5)) / (65) ] + (15)
58	!
59	Elself ('HR 24hour ave Flow' < 1001) Then
60	! Allowable diversion is 30 percent of prior days flow.
61	'Canal Dam Flow Diversion' = 0.3 * 'HR 24hour ave Flow'

Insert New Operation

Comment New Variable Get Sim Value Set Operational Param Branch (If/Else) Math Table

Current Selection Changes

Math Operation

Assign Result

Existing Variable

New Variable

Canal Dam Flow Diversion

Expression

HR 24hour

49.5

65

15



# Determine Diversion



```
63 Else
64     ! Diversion capped at 300cfs.
65     'Canal Dam Flow Diversion' = 300
66 End If
67 !
68 ! Allowable volume diversion is allowable flow in cfs times 86400 seconds in a day.
69 'Canal Dam Vol Diversion' = ('Canal Dam Flow Diversion') * (86400)
70 !
71 ! The Gates are only adjusted once. In order to make sure the full-allowable-amount is diverted;
72 ! The Volume is to be diverted in ~20 hours and then the gates will be closed.
73 ! So 24 hour flow is multiplied by 1.2 to get 20 hour flow.
74 'Canal Dam 20hour flow' = ('Canal Dam Flow Diversion') * (1.2)
75 !
76 ! Convert 20 hour cfs flow to 20 hour MGD flow.
77 'Canal Dam 20 hour MGD' = 0.646317 * 'Canal Dam 20hour flow'
78 !
79 ! Get the Head on each gate group from lookup tables.
80 'Head Opening #1' = Table Lookup(Flow MGD, Interpolate value)
81 'Head Opening #2' = Table Lookup(Flow MGD, Interpolate value)
82 'Head Opening #3' = Table Lookup(Flow MGD, Interpolate value)
83 !
84 ! Initialize user gate opening variables to zero
85 ! (These are user defined variables. The gates are not yet being set)
86 'Gate Opening #1' = 0
87 'Gate Opening #2' = 0
88 'Gate Opening #3' = 0
89 !
90 ! Get the WSEL just upstream of Canal Dam.
91 ! Then back out the gate opening from the desired Head on each gate.
92 !
93 'Wsel Upstream' = Cross Sections:WS Elevation(Diversion Canal,1,73.75,Value at current time step)
94 !
95 If ('Head Opening #1' > 0) Then
```



# Get Head from Lookup Table



Operation Rules

Rule Based Operations

row	Operation
77	'Canal Dam 20 hour MGD' = 0.646317 * 'Canal Dam 20hour
78	!
79	! Get the Head on each gate group from lookup tables.
80	'Head Opening #1' = Table Lookup(Flow MGD, Interpolate
81	'Head Opening #2' = Table Lookup(Flow MGD, Interpolate
82	'Head Opening #3' = Table Lookup(Flow MGD, Interpolate
83	!
84	! Initialize user gate opening variables to zero
85	! (These are user defined variables. The gates are not yet
86	'Gate Opening #1' = 0
87	'Gate Opening #2' = 0
88	'Gate Opening #3' = 0
89	!
90	! Get the WSEL just upstream of Canal Dam.
91	! Then back out the gate opening from the desired Head o

Insert New Operation

Comment    New Variable    Get Sim Value    Set Operational Param    Branch (If/Else)    Ma

Table Lookup

Assign Result

Existing Variable

New Variable

Head Opening #1

One Dimensional Table (Single Interpolation)

Two Dimensional Table (2-way Interpolation)

Argument Name: Flow MGD

Interpolate value

Enter/Edit Table Data ...

Expression

Edit ... X

'Canal Dam

Rule Table

Table Data

	Flow MGD	Head Opening #1
1	0	0
2	9.96	1
3	13.08	1.2
4	16.48	1.4
5	20.13	1.6
6	24.01	1.8
7	28.11	2
8	32.43	2.2
9	36.94	2.4
10	41.65	2.6
11	46.54	2.8
12	51.61	3
13	56.22	2
14	64.85	2.2
15	73.88	2.4
16	83.29	2.6
17	93.08	2.8
18	103.21	3
19	110.82	2.4
20	124.94	2.6
21	139.61	2.8
22	154.82	3
23	170.54	3.2
24	186.76	3.4

OK    Cancel



# Determine Gate Opening from Head



Operation Rules

Rule Based Operations

row	Operation
91	! Then back out the
92	!
93	'Wsel Upstream' = C
94	!
95	If ('Head Opening #1
96	!
97	! Head is greater
98	! The desired Hea
99	!
100	'Gate Opening #1' = 'Head Opening #1' + 22.5 - 'Wsel Upstream'
101	End If
102	!
103	! Set gate #1 to the new opening height (finally!)
104	!
105	Gate.Opening(Gate #1) = 'Gate Opening #1'

### Edit Rule Expression

( Exponent Coef \* Exponent Variable )

Coefficient \* Variable + Constant

Current Expression: 'Head Opening #1' + 22.5

Clear Expression OK Cancel

Insert New Operation

Comment New Variable Get Sim Value Set Operational Param Branch (If/Else) Math Table

Current Selection Changes

Math Operation

Assign Result

Existing Variable

New Variable

Gate Opening #1

Expression Edit X

'Head

Expression Edit ... X

'Wsel

Expression Edit ... X

[not set]

Expression Edit ... X

[not set]



# Set Gate Opening



```
93 'Wsel Upstream' = Cross Sections:WS Elevation(Diversion Canal,1,73.75,Value at current time step)
94 !
95 If ('Head Opening #1' > 0) Then
96     !
97     ! Head is greater than zero. Determined gate opening for this gate.
98     ! The desired Head plus 22.5 minus the upstream water surface will give the drop gate opening.
99     !
100     'Gate Opening #1' = 'Head Opening #1' + 22.5 - 'Wsel Upstream'
101 End If
102 !
103 ! Set gate #1 to the new opening height (finally!)
104 !
105 Gate.Opening(Gate #1) = 'Gate Opening #1'
106 !
107 ! Repeat for gate #2 and #3.
108 !
109 If ('Head Opening #2' > 0) Then
110     'Gate Opening #2' = 'Head Opening #2' + 22.5 - 'Wsel Upstream'
111 End If
112 Gate.Opening(Gate #2) = 'Gate Opening #2'
113 !
114 If ('Head Opening #3' > 0) Then
115     'Gate Opening #3' = 'Head Opening #3' + 22.5 - 'Wsel Upstream'
116 End If
117 Gate.Opening(Gate #3) = 'Gate Opening #3'
118 !
119 ! This is the end of the midnight (once-a-day) operations
120 !
121 End If
122 !
123 ! Get the four hour running average flow at Green Dam.
```



# Shut Gates



row	Operation
124	'Green Dam 4 Hour Ave Flow' = Inline Structures:Structure.Total Flow(Green,2,600042,Average over previous time window,4,0)
125	!
126	! Check if the allowable amount of flow has been diverted.
127	! Check if the four hour average running flow at Green Dam is less than 10 cfs.
128	!
- 129	If ('Canal Dam Vol since midnight' >= 'Canal Dam Vol Diversion') Or ('Green Dam 4 Hour Ave Flow' < 10) Then
130	!
131	! Either the allowable volume has been diverted or the Green Dam flow is too low.
132	! Make sure all the gates are closed.
133	!
134	Gate.Opening(Gate #1) = 0
135	Gate.Opening(Gate #2) = 0
136	Gate.Opening(Gate #3) = 0
137	!
138	End If
139	!
140	! End of Canal Dam rule set.

Insert New Operation

Comment    New Variable    Get Sim Value    Set Operational Param    Branch (If/Else)    Math    Table

Current Selection Changes:    Enable    Disable    Copy descriptions to Clipboard

---

Get Simulation Value

Assign Result

Existing Variable

New Variable

Green Dam 4 Hour Ave Flow

Inline Structures

- Structure.Total Flow
- Weir.Flow
- Weir.Flow Maximum**
- Weir.Flow Minimum**

Set Node Location

River:

Reach:

RS:

Average over previous time window:

Lookback Start (hrs ago):

Lookback End (hrs ago):



# Collapsed View



```
22      !
23      ! Check to see if it is midnight.
24      !
25      ! Get Day of Month for the beginning and end of the time step.
26      'Day Beg time step' = Time:Day of Month(Beginning of time step)
27      'Day End time step' = Time:Day of Month(End of time step)
28      !
29      ! If time is midnight then determine next days diversion; if any.
30      !
31-1... If ('Day Beg ti ...
122     !
123     ! Get the four hour running average flow at Green Dam.
124     'Green Dam 4 Hour Ave Flow' = Inline Structures:Structure.Total Flow(Green,2,600042,Average over previous
125     !
126     ! Check if the allowable amount of flow has been diverted.
127     ! Check if the four hour average running flow at Green Dam is less than 10 cfs.
128     !
129     If ('Canal Dam Vol since midnight' >= 'Canal Dam Vol Diversion') Or ('Green Dam 4 Hour Ave Flow' < 10) Then
130         !
131         ! Either the allowable volume has been diverted or the Green Dam flow is too low.
132         ! Make sure all the gates are closed.
133         !
134         Gate.Opening(Gate #1) = 0
135         Gate.Opening(Gate #2) = 0
136         Gate.Opening(Gate #3) = 0
137         !
138     End If
139     !
140     ! End of Canal Dam rule set.
```