



**US Army Corps  
of Engineers®**

Hydrologic Engineering Center

---

# Hydrologic Modeling System HEC-HMS

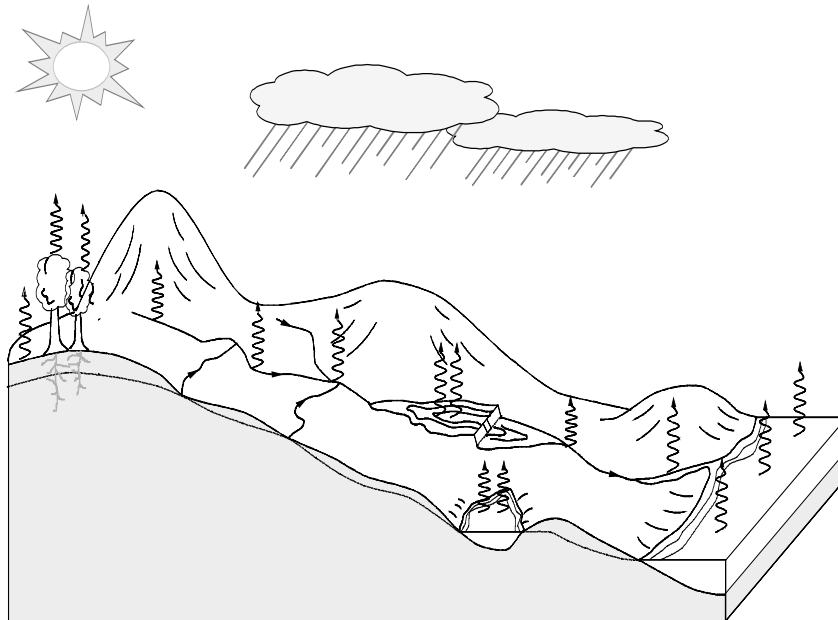

## ***User's Manual***

Version 4.2  
August 2016

**REPORT DOCUMENTATION PAGE**

Form Approved OMB No. 0704-0188

The public reporting burden for this collection of information is estimated to average 1 hour per response, including the time for reviewing instructions, searching existing data sources, gathering and maintaining the data needed, and completing and reviewing the collection of information. Send comments regarding this burden estimate or any other aspect of this collection of information, including suggestions for reducing this burden, to the Department of Defense, Executive Services and Communications Directorate (0704-0188). Respondents should be aware that notwithstanding any other provision of law, no person shall be subject to any penalty for failing to comply with a collection of information if it does not display a currently valid OMB control number.  
**PLEASE DO NOT RETURN YOUR FORM TO THE ABOVE ORGANIZATION.**

<b>1. REPORT DATE (DD-MM-YYYY)</b> August 2016		<b>2. REPORT TYPE</b> Computer Program Document		<b>3. DATES COVERED (From - To)</b>	
<b>4. TITLE AND SUBTITLE</b> Hydrologic Modeling System HEC-HMS User's Manual			<b>5a. CONTRACT NUMBER</b>		
			<b>5b. GRANT NUMBER</b>		
			<b>5c. PROGRAM ELEMENT NUMBER</b>		
<b>6. AUTHOR(S)</b> W. Scharffenberg			<b>5d. PROJECT NUMBER</b>		
			<b>5e. TASK NUMBER</b>		
			<b>5f. WORK UNIT NUMBER</b>		
<b>7. PERFORMING ORGANIZATION NAME(S) AND ADDRESS(ES)</b> U.S. Army Corps of Engineers Institute for Water Resources Hydrologic Engineering Center (CEIWR-HEC) 609 Second Street Davis, CA 95616-4687			<b>8. PERFORMING ORGANIZATION REPORT NUMBER</b> CPD-74A		
<b>9. SPONSORING/MONITORING AGENCY NAME(S) AND ADDRESS(ES)</b>			<b>10. SPONSOR/ MONITOR'S ACRONYM(S)</b>		
			<b>11. SPONSOR/ MONITOR'S REPORT NUMBER(S)</b>		
<b>12. DISTRIBUTION / AVAILABILITY STATEMENT</b> Approved for public release; distribution is unlimited.					
<b>13. SUPPLEMENTARY NOTES</b>					
<b>14. ABSTRACT</b> <p>The Hydrologic Modeling System (HEC-HMS) is designed to simulate the complete hydrologic processes of dendritic watershed systems. In includes many traditional hydrologic analysis procedures such as event infiltration, unit hydrographs, and hydrologic routing. It also includes procedures necessary for continuous simulation including evapo-transpiration, snowmelt, and soil moisture accounting. Gridded runoff simulation can also be performed. Supplemental analysis tools are provided for parameter estimation, depth-area analysis, flow forecasting, uncertainty assessment, erosion and sediment transport, and nutrient water quality.</p> <p>The program features an integrated work environment with data entry utilities, computation engine, and results reporting tools. A graphical user interface allows seamless movement between the different parts of the program. Simulation results are stored in the Data Storage System HEC-DSS and can be used in conjunction with other software for studies of water availability, urban drainage, flow forecasting, future urbanization impact, reservoir spillway design, flood damage reduction, floodplain regulation, and systems operation.</p>					
<b>15. SUBJECT TERMS</b> Hydrology, watershed, precipitation runoff, river routing, flood frequency, flood control, water supply, computer simulation, environmental restoration.					
<b>16. SECURITY CLASSIFICATION OF:</b>			<b>17. LIMITATION OF ABSTRACT</b> UU	<b>18. NUMBER OF PAGES</b> 612	<b>19a. NAME OF RESPONSIBLE PERSON</b>
<b>a. REPORT</b> U	<b>b. ABSTRACT</b> U	<b>c. THIS PAGE</b> U			<b>19b. TELEPHONE NUMBER</b>

# Hydrologic Modeling System HEC-HMS

## *User's Manual*

**Version 4.2**  
**August 2016**

US Army Corps of Engineers  
Institute for Water Resources  
Hydrologic Engineering Center  
609 Second Street  
Davis, CA 95616 USA

Phone 530.756.1104  
Fax 530.756.8250  
Email [hec.hms@usace.army.mil](mailto:hec.hms@usace.army.mil)

## Hydrologic Modeling System HEC-HMS, User's Manual

2016. This Hydrologic Engineering Center (HEC) Manual is a U.S. Government document and is not subject to copyright. It may be copied and used free of charge. Please acknowledge the U.S. Army Corps of Engineers Hydrologic Engineering Center as the author of this Manual in any subsequent use of this work or excerpts.

Use of the software described by this Manual is controlled by certain terms and conditions. The user must acknowledge and agree to be bound by the terms and conditions of usage before the software can be installed or used. For reference, a copy of the terms and conditions of usage are included in Appendix E of this document so that they may be examined before obtaining the software.

This document contains references to product names that are used as trademarks by, or are federally registered trademarks of, their respective owners. Use of specific product names does not imply official or unofficial endorsement. Product names are used solely for the purpose of identifying products available in the public market place.

*Intel* and *Pentium* are registered trademarks of Intel Corp.

*Linux* is a registered trademark of Linus Torvalds.

*Microsoft* and *Windows* are registered trademarks of Microsoft Corp. *Vista* is a trademark of Microsoft Corp.

*RED HAT* is a registered trademark of Red Hat, Inc.

*Java* is a trademark of Oracle, Inc.



Please consider the environment before printing this document, and recycle if you do.

<b>PREFACE</b>	<b>XIII</b>
<b>INTRODUCTION</b>	<b>1</b>
SCOPE .....	1
HISTORY .....	1
CAPABILITIES.....	3
Watershed Physical Description .....	3
Meteorology Description .....	4
Hydrologic Simulation .....	6
Parameter Estimation .....	6
Analyzing Simulations.....	6
Forecasting Future Flows .....	6
Sediment and Water Quality .....	7
GIS Connection.....	7
LIMITATIONS .....	7
Model Formulation .....	8
Flow Representation .....	8
DOCUMENTATION CONVENTIONS.....	9
REFERENCES .....	9
<b>INSTALLING AND RUNNING THE PROGRAM</b>	<b>11</b>
OPERATING SYSTEM REQUIREMENTS .....	11
HARDWARE REQUIREMENTS AND RECOMMENDATIONS .....	11
INSTALLATION.....	12
Microsoft Windows Operating System .....	12
Linux Operating System.....	13
RUNNING THE PROGRAM.....	14
Microsoft Windows Operating System .....	15
Linux Operating System.....	15
COMMAND LINE OPERATION.....	15
MANAGING MEMORY ALLOCATION .....	17
ADDITIONAL RESOURCES .....	17
<b>OVERVIEW</b>	<b>19</b>
PROGRAM SCREEN.....	19
Menu System .....	19
Toolbar .....	25
Watershed Explorer .....	25
Desktop .....	27
Component Editor .....	28
Message Log.....	29
PROGRAM SETTINGS .....	29
DATA CONVENTIONS.....	31
Saving Properties.....	31
Number Formatting .....	32
Date and Time Formatting .....	32
Units Conversion.....	33
Interpolation .....	34
APPLICATION STEPS .....	34
Create a New Project .....	34
Enter Shared Project Data .....	35
Describe the Physical Watershed .....	37
Describe the Meteorology .....	41
Enter Simulation Time Windows .....	42
Simulate and View Results .....	42

Create or Modify Data .....	45
Make Additional Simulations and Compare Results .....	46
Exit the Program .....	47
REFERENCES .....	47
<b>PROJECTS AND CONTROL SPECIFICATIONS</b>	<b>49</b>
PROJECTS .....	49
Creating a New Project.....	49
Opening a Project.....	50
Copying a Project .....	51
Renaming a Project.....	52
Deleting a Project .....	53
Project Properties .....	54
DIRECTORIES AND FILES.....	55
Files Generated by the Program .....	55
Files Specified by the User .....	57
Manually Entered Time-Series and Paired Data .....	57
Computed Results .....	57
External Time-Series, Paired, and Grid Data .....	58
Security Limitations .....	58
CONTROL SPECIFICATIONS .....	59
Creating a New Control Specifications.....	59
Copying a Control Specifications .....	60
Renaming a Control Specifications .....	61
Deleting a Control Specifications .....	63
Time Window .....	65
Time Interval.....	66
Gridded Data Output Interval.....	67
Grid Time Shift.....	67
IMPORTING HEC-1 FILES.....	68
Selecting and Processing a File .....	68
Unsupported Features.....	69
REFERENCES.....	71
<b>SHARED COMPONENT DATA</b>	<b>73</b>
TIME-SERIES DATA .....	73
Creating a New Gage .....	73
Copying a Gage.....	75
Renaming a Gage .....	76
Deleting a Gage.....	78
Time Windows .....	79
Data Source.....	83
Data Units.....	84
Time Interval.....	85
Elevation.....	86
Reference Height.....	86
Latitude and Longitude .....	86
Manual Entry .....	88
Single Record HEC-DSS.....	88
Multiple Record HEC-DSS .....	92
Table.....	93
Graph.....	94
PAIRED DATA.....	95
Creating a New Curve .....	95
Copying a Curve.....	97
Renaming a Curve.....	98

Deleting a Curve .....	99
Data Source .....	101
Data Units .....	102
Time Intervals .....	103
Retrieval From a HEC-DSS File .....	103
Table .....	107
Graph .....	108
GRID DATA.....	109
Creating a New Grid .....	109
Copying a Grid .....	110
Renaming a Grid.....	112
Deleting a Grid .....	113
Retrieval From a HEC-DSS File .....	115
REFERENCES .....	122
<b>WATERSHED PHYSICAL DESCRIPTION</b>	<b>123</b>
BASIN MODELS.....	123
Creating a New Basin Model .....	123
Copying a Basin Model .....	124
Renaming a Basin Model.....	126
Deleting a Basin Model .....	127
Importing a Basin Model .....	128
BASIN MODEL PROPERTIES.....	129
Gridded Subbasins .....	129
Local Flow.....	130
Flow Ratio .....	130
Missing Flow .....	131
Unit System.....	131
Sediment.....	131
Water Quality .....	131
BASIN MODEL MAP .....	132
Background Maps .....	132
Maximum Extents .....	134
Background Gridlines.....	135
Adjusting the View and Zooming .....	136
Drawing Elements and Labels .....	137
Displaying Flow Directions.....	139
HYDROLOGIC ELEMENTS.....	139
Creating a New Element .....	139
Copying an Element.....	141
Pasting an Element.....	142
Cutting an Element .....	143
Renaming an Element .....	144
Deleting an Element.....	144
Optional Element Properties .....	146
Element Inventory .....	148
Finding and Selecting Elements .....	148
FLOW NETWORK.....	150
Moving Elements .....	150
Rescaling Elements .....	151
Locking Element Locations.....	152
Connecting and Disconnecting Elements .....	152
Hydrologic Order.....	154
Locking Hydrologic Order .....	158
ZONES .....	159
Creating a New Zone Configuration.....	159

Copying a Zone Configuration.....	161
Renaming a Zone Configuration .....	161
Deleting a Zone Configuration.....	162
Creating a Zone in a Configuration .....	163
Renaming a Zone in a Configuration.....	164
Deleting a Zone from a configuration .....	165
Adding Elements to a Zone .....	165
Removing Elements from a Zone.....	167
Selecting a Current Zone Configuration.....	168
COMPUTATION POINTS .....	171
Selecting Computation Points .....	171
Unselecting Computation Points .....	174
Selecting Calibration Parameters.....	175
Unselecting Calibration Parameters.....	178
Settings for Calibration Parameters .....	179
Computation Point Results.....	180
REFERENCES.....	183
<b>SUBBASIN ELEMENTS</b>	<b>185</b>
SELECTING A CANOPY METHOD .....	185
Dynamic Canopy .....	186
Gridded Simple Canopy .....	188
Simple Canopy .....	189
SELECTING A SURFACE METHOD .....	190
Gridded Simple Surface .....	192
Simple Surface .....	192
SELECTING A LOSS METHOD.....	193
Deficit and Constant Loss.....	194
Exponential Loss .....	195
Green and Ampt Loss.....	196
Gridded Deficit Constant Loss.....	196
Gridded Green and Ampt Loss.....	198
Gridded SCS Curve Number Loss .....	199
Gridded Soil Moisture Accounting.....	200
Initial and Constant Loss .....	202
SCS Curve Number Loss .....	202
Smith Parlange Loss .....	203
Soil Moisture Accounting Loss .....	205
SELECTING A TRANSFORM METHOD.....	207
Clark Unit Hydrograph Transform .....	208
Kinematic Wave Transform .....	209
ModClark Transform.....	213
SCS Unit Hydrograph Transform.....	214
Snyder Unit Hydrograph Transform .....	215
User-Specified S-Graph Transform.....	218
User-Specified Unit Hydrograph Transform .....	219
SELECTING A BASEFLOW METHOD .....	221
Bounded Recession Baseflow.....	222
Constant Monthly Baseflow .....	223
Linear Reservoir Baseflow .....	223
Nonlinear Boussinesq Baseflow.....	224
Recession Baseflow .....	226
REFERENCES.....	227
<b>REACH ELEMENTS</b>	<b>229</b>
SELECTING A ROUTING METHOD .....	229



Kinematic Wave Routing.....	230
Lag Routing.....	232
Modified Puls Routing.....	232
Muskingum Routing.....	234
Muskingum-Cunge Routing.....	234
Straddle Stagger Routing.....	236
SELECTING A LOSS/GAIN METHOD.....	236
Constant Loss/Gain.....	237
Percolation Loss/Gain.....	238
<b>RESERVOIR ELEMENTS</b>	<b>241</b>
SELECTING A ROUTING METHOD.....	241
OUTFLOW CURVE ROUTING.....	242
Storage Method.....	242
Initial Condition.....	243
SPECIFIED RELEASE ROUTING.....	244
Storage Method.....	244
Initial Condition.....	245
Discharge Gage Selection.....	245
Discharge Limit Options.....	246
OUTFLOW STRUCTURES ROUTING.....	246
Storage Method.....	246
Initial Condition.....	248
Tailwater Method.....	248
Auxiliary Discharge Location.....	249
Time Step Control.....	250
Outlets.....	250
Spillways.....	254
Spillway Gates.....	257
Controlling Spillway Gates.....	259
Dam Tops.....	259
Pumps.....	261
Dam Break.....	263
Dam Seepage.....	266
Additional Release.....	267
Evaporation.....	268
<b>SOURCE, JUNCTION, DIVERSION, AND SINK ELEMENTS</b>	<b>271</b>
SOURCE.....	271
Representative Area.....	271
Selecting an Inflow Method.....	272
Discharge Gage.....	272
Constant Flow.....	273
JUNCTION.....	274
DIVERSION.....	274
Connecting Diversion Flow.....	275
Limiting Flow or Volume.....	275
Selecting a Divert Method.....	276
Constant Flow Divert.....	276
Inflow Function Divert.....	277
Lateral Weir Divert.....	278
Pump Station Divert.....	279
Specified Flow Divert.....	281
SINK.....	282

<b>METEOROLOGY DESCRIPTION</b>	<b>283</b>
METEOROLOGIC MODELS .....	283
Creating a New Meteorologic Model .....	283
Copying a Meteorologic Model .....	284
Renaming a Meteorologic Model .....	286
Deleting a Meteorologic Model .....	287
Importing a Meteorologic Model .....	288
Shortwave Radiation Method .....	289
Longwave Radiation Method .....	290
Precipitation Method .....	290
Evapotranspiration Method .....	291
Snowmelt Method .....	292
Unit System .....	292
Missing Data .....	293
Selecting Basin Models .....	293
Atmospheric Variables .....	295
SHORTWAVE RADIATION .....	296
Bristow Campbell .....	297
FAO56 .....	299
Gridded Shortwave .....	301
Specified Pyranograph .....	302
LONGWAVE RADIATION .....	304
FAO56 .....	304
Gridded Longwave .....	306
Satterlund .....	307
Specified Pyrgeograph .....	309
PRECIPITATION .....	310
Frequency Storm .....	310
Gage Weights .....	313
Gridded Precipitation .....	318
HMR 52 Storm .....	319
Inverse Distance .....	321
SCS Storm .....	324
Specified Hyetograph .....	325
Standard Project Storm .....	327
EVAPOTRANSPIRATION .....	329
Annual Evapotranspiration .....	330
Gridded Penman Monteith .....	331
Gridded Priestley Taylor .....	333
Monthly Average .....	334
Penman Monteith .....	335
Priestley Taylor .....	336
Specified Evapotranspiration .....	338
SNOWMELT .....	339
Gridded Temperature Index .....	340
Temperature Index .....	344
REFERENCES .....	351
<b>HYDROLOGIC SIMULATION</b>	<b>353</b>
SIMULATION RUNS .....	353
Creating a New Run .....	353
Copying a Run .....	355
Renaming a Run .....	357
Deleting a Run .....	358
Importing a Run .....	360
Selecting Components .....	362

Simulation Results Output .....	363
Precipitation and Flow Ratios .....	363
Start and Saved States .....	364
COMPUTING RESULTS FOR A RUN.....	366
Selecting a Current Simulation Run.....	367
Computing a Simulation Run .....	367
Computing to a Computation Point.....	368
Using Calibration Aids at a Computation Point.....	369
Computing Multiple Runs.....	371
VIEWING RESULTS FOR THE CURRENT RUN .....	372
Global Summary Table .....	373
Individual Elements.....	374
VIEWING RESULTS FOR OTHER RUNS .....	377
Global Summary Table .....	377
Individual Elements.....	378
Element Time-Series Preview Graph .....	379
Time-Series Tables and Graphs .....	379
Changing Graph Properties .....	381
<b>MODEL OPTIMIZATION .....</b>	<b>383</b>
OPTIMIZATION TRIALS .....	383
Creating a New Optimization Trial.....	384
Copying an Optimization Trial.....	387
Renaming an Optimization Trial .....	389
Deleting an Optimization Trial.....	390
Selecting Components.....	392
Entering a Time Window .....	393
Search Method.....	393
Objective Function .....	394
Adding and Deleting Parameters .....	396
Specifying Parameter Information .....	401
COMPUTING RESULTS FOR A TRIAL.....	402
Selecting a Current Optimization Trial .....	402
Computing an Optimization Trial .....	403
Computing Multiple Trials .....	404
VIEWING RESULTS FOR THE CURRENT TRIAL .....	405
Objective Function Table .....	405
Optimized Parameters Table .....	406
Hydrograph Comparison Graph.....	407
Flow Comparison Graph .....	408
Flow Residuals Graph.....	409
Objective Function Graph .....	410
Individual Elements.....	411
VIEWING RESULTS FOR OTHER TRIALS .....	415
Trial Results .....	415
Individual Elements.....	416
Element Time-Series Preview Graph .....	416
Time-Series Tables and Graphs .....	418
Changing Graph Properties .....	419
<b>FORECASTING STREAMFLOW .....</b>	<b>421</b>
FORECAST ALTERNATIVES .....	421
Creating a New Forecast Alternative.....	422
Copying a Forecast Alternative.....	425
Renaming a Forecast Alternative.....	427
Deleting a Forecast Alternative.....	428

Selecting Components .....	430
Entering a Time Window .....	431
Selecting Zone Configurations .....	431
ADJUSTING PARAMETERS FOR THE FORECAST.....	432
Zone Parameter Adjustments.....	432
Element Parameter Overrides .....	433
Slider Adjustments.....	435
SUBBASIN BASEFLOW INITIALIZATION .....	439
RESERVOIR POOL INITIALIZATION AND RESET .....	441
BLENDING COMPUTED FLOW WITH OBSERVED FLOW .....	444
COMPUTING RESULTS FOR AN ALTERNATIVE .....	445
Selecting a current Forecast Alternative .....	445
Computing a Forecast Alternative .....	446
Computing to a Computation Point .....	447
Computing Multiple Alternatives.....	448
VIEWING RESULTS FOR THE CURRENT ALTERNATIVE .....	449
Individual Elements .....	450
VIEWING RESULTS FOR OTHER ALTERNATIVES .....	453
Individual Elements .....	453
Element Time-Series Preview Graph .....	454
Time-Series Tables and Graphs .....	456
Changing Graph Properties.....	457
<b>DEPTH-AREA REDUCTION</b> .....	<b>459</b>
DEPTH-AREA ANALYSES.....	459
Creating a New Depth-Area Analysis .....	460
Copying a Depth-Area Analysis .....	462
Renaming a Depth-Area Analysis .....	463
Deleting a Depth-Area Analysis .....	465
Selecting a Simulation Run .....	466
Selecting Analysis Points .....	467
COMPUTING RESULTS FOR AN ANALYSIS .....	467
Selecting a Current Depth-Area Analysis.....	468
Computing a Depth-Area Analysis .....	468
Computing Multiple Analyses .....	469
VIEWING RESULTS FOR THE CURRENT ANALYSIS .....	470
Peak Flow Summary Table .....	471
Individual Elements .....	471
VIEWING RESULTS FOR OTHER ANALYSES .....	475
Peak Flow Summary Table .....	476
Individual Elements .....	476
Element Time-Series Preview Graph .....	477
Time-Series Tables and Graphs .....	478
Changing Graph Properties.....	479
<b>ASSESSING MODEL UNCERTAINTY</b> .....	<b>481</b>
UNCERTAINTY ANALYSES .....	481
Creating a New Uncertainty Analysis .....	483
Copying an Uncertainty Analysis.....	485
Renaming an Uncertainty Analysis .....	486
Deleting an Uncertainty Analysis.....	488
Selecting Components .....	490
Entering a Time Window .....	491
Total Samples and Convergence .....	491
Adding and Deleting Parameters .....	492
Specifying Parameter Information .....	498

COMPUTING RESULTS FOR AN ANALYSIS.....	504
Choosing Output Results.....	504
Selecting a Current Uncertainty Analysis.....	507
Computing an Uncertainty Analysis.....	507
Computing Multiple Analyses.....	508
VIEWING RESULTS FOR AN ANALYSIS.....	509
Sampled Parameters.....	510
Individual Elements.....	512
<b>EROSION AND SEDIMENT TRANSPORT</b>	<b>519</b>
WATERSHED SEDIMENT PROPERTIES.....	519
SUBBASIN.....	522
Selecting an Erosion Method.....	523
Build-up Wash-off.....	524
Modified USLE.....	525
REACH.....	527
Selecting a Sediment Method.....	528
Fisher's Dispersion.....	529
Linear Reservoir.....	531
Uniform Equilibrium.....	532
Volume Ratio.....	534
RESERVOIR.....	535
Selecting a Sediment Method.....	536
Complete Sediment Trap.....	537
Specified Sediment.....	537
Chen Sediment Trap.....	538
Zero Sediment Trap.....	539
SOURCE.....	539
Selecting a Sediment Method.....	539
Annual Load.....	540
Specified Load.....	541
JUNCTION.....	542
DIVERSION.....	542
Selecting a Sediment Method.....	543
Passage Efficiency.....	544
Specified Load.....	545
SINK.....	545
VIEWING EROSION AND SEDIMENT RESULTS.....	546
Subbasin.....	547
Reach.....	548
Reservoir.....	549
Source.....	550
Junction.....	550
Diversion.....	550
Sink.....	550
REFERENCES.....	550
<b>WATER QUALITY</b>	<b>553</b>
NUTRIENT PROCESSES AFFECTING WATER QUALITY.....	553
WATERSHED CHEMICAL PROPERTIES.....	555
SUBBASIN.....	560
Selecting a Quality Method.....	561
Constant Concentration.....	562
Specified Concentration.....	563
REACH.....	564
Selecting a Quality Method.....	565

Nutrient Simulation Module .....	566
RESERVOIR .....	568
Selecting a Quality Method .....	569
Nutrient Simulation Module .....	569
SOURCE .....	571
Selecting a Quality Method .....	572
Constant Concentration .....	572
Specified Concentration .....	573
JUNCTION .....	574
DIVERSION.....	575
SINK.....	575
VIEWING WATER QUALITY RESULTS.....	575
Subbasin.....	576
Reach .....	576
Reservoir .....	577
Source .....	578
Junction .....	578
Diversion.....	579
Sink.....	579
REFERENCES.....	580
<b>DATA STORAGE IN HEC-DSS</b> .....	<b>581</b>
DESCRIPTORS.....	581
<b>GRID CELL FILE FORMAT</b> .....	<b>587</b>
FILE DEFINITION .....	587
<b>MAP FILE FORMAT</b> .....	<b>591</b>
FILE DEFINITION .....	591
<b>HEC-HMS AND HEC-1 DIFFERENCES</b> .....	<b>593</b>
RECESSION BASEFLOW .....	593
CLARK UNIT HYDROGRAPH.....	593
MUSKINGUM CUNGE ROUTING .....	594
General Channel Properties .....	594
Eight Point Cross Sections .....	594
KINEMATIC WAVE ROUTING .....	595
OGEE SPILLWAY FLOW.....	595
GREEN AND AMPT INFILTRATION .....	595
<b>TERMS AND CONDITIONS OF USE</b> .....	<b>597</b>
TERMS AND CONDITIONS OF USE .....	597

# **PREFACE**

This Manual is not intended to teach you how to do hydrologic engineering or even hydrology. It does not describe the mathematical equations for the various models included in the program. So what does it do? This Manual will teach you how to use the various features and capabilities of the program. It works very well to simply read the Manual through starting at the beginning. If you read the Manual in front of your computer with the program up and running, it will work even better. However, the Manual works equally well as an occasional reference when you cannot remember exactly how to perform a certain task or need to check the parameter definitions for a particular method.

The scope of this Manual does not mean that we think engineering applications or mathematical analysis are unimportant. In fact, both of those things are vital to producing good engineering plans and designs. We feel they are so important that we have created a separate Manual for each of them. The Technical Reference Manual provides detailed descriptions of each of the models included in the program. You can expect to find the mathematical derivation of the model equations, details on the numerical schemes employed in the program to solve the equations, and specific guidance on parameter estimation. Consequently, it focuses less on using the program and more on understanding the science of hydrology. The Applications Guide provides practical suggestions for using the program to perform engineering work. We selected a number of typical projects that engineers often encounter and showed how the program can be used to provide real answers. Consequently, it focuses less on using the program and more on the engineering process.

Many engineers, computer specialists, and student interns have contributed to the success of this project. Each one has made valuable contributions that enhance the overall success of the program. Nevertheless, the completion of this version of the program was overseen by David J. Harris while Christopher N. Dunn was director of the Hydrologic Engineering Center. Development and testing of this release was led by William A. Scharffenberg.

This Page Left Blank



# CHAPTER 1

## ***Introduction***

The Hydrologic Modeling System is designed to simulate the precipitation-runoff processes of dendritic watershed systems. It is designed to be applicable in a wide range of geographic areas for solving the widest possible range of problems. This includes large river basin water supply and flood hydrology, and small urban or natural watershed runoff. Hydrographs produced by the program are used directly or in conjunction with other software for studies of water availability, urban drainage, flow forecasting, future urbanization impact, reservoir spillway design, flood damage reduction, floodplain regulation, and systems operation.

## ***Scope***

The program is a generalized modeling system capable of representing many different watersheds. A model of the watershed is constructed by separating the hydrologic cycle into manageable pieces and constructing boundaries around the watershed of interest. Any mass or energy flux in the cycle can then be represented with a mathematical model. In most cases, several model choices are available for representing each flux. Each mathematical model included in the program is suitable in different environments and under different conditions. Making the correct choice requires knowledge of the watershed, the goals of the hydrologic study, and engineering judgment.

The program features a completely integrated work environment including a database, data entry utilities, computation engine, and results reporting tools. A graphical user interface allows the seamless movement between the different parts of the program. Program functionality and appearance are the same across all supported platforms.

## ***History***

The computation engine draws on over 30 years experience with hydrologic simulation software. Many algorithms from HEC-1 (HEC, 1998), HEC-1F (HEC, 1989), PRECIP (HEC, 1989), and HEC-IFH (HEC, 1992) have been modernized and combined with new algorithms to form a comprehensive library of simulation routines. Future versions of the program will continue to modernize desirable

algorithms from legacy software. The current research program is designed to produce new algorithms and analysis techniques for addressing emerging problems.

The initial program release was called Version 1.0 and included most of the event-simulation capabilities of the HEC-1 program. It did introduce several notable improvements over the legacy software including an unlimited number of hydrograph ordinates and gridded runoff representation. The tools for parameter estimation with optimization were much more flexible than in previous programs. The maiden release also included a number of "firsts" for HEC including object-oriented development in the C++ language and multiplatform support in a program with a graphical user interface.

The second major release was called Version 2.0 and focused on continuous simulation. The addition of the soil moisture accounting method extended the program from an event-simulation package to one that could work equally well with event or continuous simulation applications. The reservoir element was also expanded to include physical descriptions for an outlet, spillway, and overflow. An overtopping dam failure option was also added.

The third major release was called Version 3.0 and introduced new computation features and a brand new graphical user interface. The meteorologic model was enhanced with new methods for snowmelt and potential evapo-transpiration simulation. The basin model was enhanced with additional methods for representing infiltration in the subbasin element, and additional computational options in the diversion and reservoir elements. The new graphical user interface was designed to simplify creating and managing the many types of data needed for hydrologic simulation, and to increase user efficiency with a better-integrated work environment.

The fourth major release was called Version 4.0 and focused primarily on new computation features. A broad range of surface erosion and sediment transport features were added to the subbasin, reach, reservoir, and other elements. A preliminary capability was also added for nutrient water quality simulation. Finally, a new simulation component was added to facilitate real-time forecasting operations.

Enhancement of the program is ongoing. HEC has a strong commitment to continued research in emerging needs for hydrologic simulation, both in terms of simulation techniques and representation of physical processes. Future needs are identified by conducting our own application projects, speaking with program users, and monitoring academic journals. HEC also has a strong commitment to continued development of the program interface. Plans are already underway to add new features in a future version that will make the program easier

to use by providing more flexible ways to accomplish work. New visualization concepts are also being developed. Look for future versions to continue the tradition.

## **Capabilities**

The program has an extensive array of capabilities for conducting hydrologic simulation. Many of the most common methods in hydrologic engineering are included in such a way that they are easy to use. The program does the difficult work and leaves the user free to concentrate on how best to represent the watershed environment.

### ***Watershed Physical Description***

The physical representation of a watershed is accomplished with a basin model. Hydrologic elements are connected in a dendritic network to simulate runoff processes. Available elements are: subbasin, reach, junction, reservoir, diversion, source, and sink. Computation proceeds from upstream elements in a downstream direction.

An assortment of different methods is available to simulate infiltration losses. Options for event modeling include initial constant, SCS curve number, exponential, Green Ampt, and Smith Parlange. The one-layer deficit constant method can be used for simple continuous modeling. The three-layer soil moisture accounting method can be used for continuous modeling of complex infiltration and evapotranspiration environments. Gridded methods are available for the deficit constant, Green Ampt, SCS curve number, and soil moisture accounting methods. Canopy and surface components can also be added when needed to represent interception and capture processes.

Seven methods are included for transforming excess precipitation into surface runoff. Unit hydrograph methods include the Clark, Snyder, and SCS techniques. User-specified unit hydrograph or s-graph ordinates can also be used. The modified Clark method, ModClark, is a linear quasi-distributed unit hydrograph method that can be used with gridded meteorologic data. An implementation of the kinematic wave method with multiple planes and channels is also included.

Five methods are included for representing baseflow contributions to subbasin outflow. The recession method gives an exponentially decreasing baseflow from a single event or multiple sequential events. The constant monthly method can work well for continuous simulation. The linear reservoir method conserves mass by routing infiltrated precipitation to the channel. The nonlinear Boussinesq method provides a response similar to the recession method but the

parameters can be estimated from measurable qualities of the watershed.

A total of six hydrologic routing methods are included for simulating flow in open channels. Routing with no attenuation can be modeled with the lag method. The traditional Muskingum method is included along with the straddle stagger method for simple approximations of attenuation. The modified Puls method can be used to model a reach as a series of cascading, level pools with a user-specified storage-discharge relationship. Channels with trapezoidal, rectangular, triangular, or circular cross sections can be modeled with the kinematic wave or Muskingum-Cunge methods. Channels with overbank areas can be modeled with the Muskingum-Cunge method and an 8-point cross section. Additionally, channel losses can also be included in the routing. The constant loss method can be added to any routing method while the percolation method can be used only with the modified Puls or Muskingum-Cunge methods.

Water impoundments can also be represented. Lakes are usually described by a user-entered storage-discharge relationship. Reservoirs can be simulated by describing the physical spillway and outlet structures. Pumps can also be included as necessary to simulate interior flood area. Control of the pumps can be linked to water depth in the collection pond and, optionally, the stage in the main channel.

Diversion structures can also be represented. Available methods include a user-specified function, lateral weir, pump station, observed diversion flows.

### ***Meteorology Description***

Meteorologic data analysis is performed by the meteorologic model and includes shortwave radiation, longwave radiation, precipitation, evapo-transpiration, and snowmelt. Not all of these components are required for all simulations. Simple event simulations require only precipitation, while continuous simulation additionally requires evapo-transpiration. Generally, snowmelt is only required when working with watersheds in cold climates. Selection of energy-balance methods for evapo-transpiration or snowmelt also requires radiation methods.

Four different methods for analyzing historical precipitation are included. The user-specified hyetograph method is for precipitation data analyzed outside the program. The gage weights method uses an unlimited number of recording and non-recording gages. The Thiessen technique is one possibility for determining the weights. The inverse distance method addresses dynamic data problems. An unlimited number of recording and non-recording gages can be used to

automatically proceed when missing data is encountered. The gridded precipitation method uses radar rainfall data or other sources of gridded precipitation data.

Four different methods for producing synthetic precipitation are included. The frequency storm method uses statistical data to produce balanced storms with a specific exceedance probability. Sources of supporting statistical data include Technical Paper 40 (National Weather Service, 1961) and NOAA Atlas 2 (National Weather Service, 1973). While it was not specifically designed to do so, data can also be used from NOAA Atlas 14 (National Weather Service, 2004ab). The standard project storm method implements the regulations for precipitation when estimating the standard project flood (Corps of Engineers, 1952). The SCS hypothetical storm method implements the primary precipitation distributions for design analysis using Natural Resources Conservation Service (NRCS) criteria (Soil Conservation Service, 1986). The user-specified hyetograph method can be used with a synthetic hyetograph resulting from analysis outside the program.

Potential evapo-transpiration can be computed using monthly average values. There is also an implementation of the Priestley Taylor method and the Penman Monteith method. A gridded version of both methods is also available where the required parameters of temperature, solar radiation, and other atmospheric variables are specified on a gridded basis. A user-specified method can be used with data developed from analysis outside the program.

Snowmelt can be included for tracking the accumulation and melt of a snowpack. A temperature index method is available that dynamically computes the melt rate based on current atmospheric conditions and past conditions in the snowpack; this improves the representation of the "ripening" process. The concept of cold content is incorporated to account for the ability of a cold snowpack to freeze liquid water entering the pack from rainfall. Also available is an energy balance method that considers all of the sources and sinks of energy with respect to the snowpack in order to calculate the accumulation and melting of snow. A subbasin can be represented with elevation bands or grid cells.

The Priestley Taylor evapo-transpiration method requires the net radiation while the Penman Monteith method requires separate estimates of shortwave and longwave radiation. The energy balance snowmelt method requires both shortwave and longwave radiation. Shortwave radiation can be represented with the conceptual Bristow Campbell method that utilizes daily maximum and minimum temperature, or the Shapiro method that requires information about the cloud coverage in three layers. Longwave radiation can be

represented with the conceptual Satterlund method, or an adjunct to the Shapiro method based on the same cloud input data.

### ***Hydrologic Simulation***

The time span of a simulation is controlled by control specifications. Control specifications include a starting date and time, ending date and time, and a time interval.

A simulation run is created by combining a basin model, meteorologic model, and control specifications. Run options include a precipitation or flow ratio, capability to save all basin state information at a point in time, and ability to begin a simulation run from previously saved state information.

Simulation results can be viewed from the basin map. Global and element summary tables include information on peak flow, total volume, and other variables. A time-series table and graph are available for elements. Results from multiple elements and multiple simulation runs can also be viewed. All graphs and tables can be printed.

### ***Parameter Estimation***

Most parameters for methods included in subbasin and reach elements can be estimated automatically using optimization trials. Observed discharge must be available for at least one element before optimization can begin. Parameters at any element upstream of the observed flow location can be estimated. Seven different objective functions are available to estimate the goodness-of-fit between the computed results and observed discharge. Two different search methods can be used to minimize the objective function. Constraints can be imposed to restrict the parameter space of the search method.

### ***Analyzing Simulations***

Analysis tools are designed to work with simulation runs to provide additional information or processing. Currently, the only tool is the depth-area analysis tool. It works with simulation runs that have a meteorologic model using the frequency storm method. Given a selection of elements, the tool automatically adjusts the storm area and generates peak flows represented by the correct storm areas.

### ***Forecasting Future Flows***

The basin model includes features designed to increase the efficiency of producing forecasts of future flows in a real-time operation mode. Zones can be created that group subbasins together on the basis of similar hydrologic conditions or regional characteristics. Zones can be

assigned separately for loss rate, transform, and baseflow. The forecast alternative is a type of simulation that uses a basin model and meteorologic model in combination with control parameters to forecast future flows. Parameter values can be adjusted by zone and blending can be applied at elements with observed flow.

### ***Sediment and Water Quality***

Optional components in the basin model can be used to include sediment and water quality in an analysis. Surface erosion can be computed at subbasin elements using the MUSLE approach for rural areas or the build-up/wash-off approach for urban settings. Channel erosion, deposition, and sediment transport can be added to reach elements while sediment settling can be included in reservoir elements. Nutrient boundary conditions (nitrogen and phosphorus) can be added to source and subbasin elements. Nutrient transformations and transport can be added to reach and reservoir elements.

### ***GIS Connection***

The power and speed of the program make it possible to represent watersheds with hundreds of hydrologic elements. Traditionally, these elements would be identified by inspecting a topographic map and manually identifying drainage boundaries. While this method is effective, it is prohibitively time consuming when the watershed will be represented with many elements. A geographic information system (GIS) can use elevation data and geometric algorithms to perform the same task much more quickly. A GIS companion product has been developed to aid in the creation of basin models for such projects. It is called the Geospatial Hydrologic Modeling Extension (HEC-GeoHMS) and can be used to create basin and meteorologic models for use with the program.

## ***Limitations***

Every simulation system has limitations due to the choices made in the design and development of the software. The limitations that arise in this program are due to two aspects of the design: simplified model formulation, and simplified flow representation. Simplifying the model formulation allows the program to complete simulations very quickly while producing accurate and precise results. Simplifying the flow representation aids in keeping the compute process efficient and reduces duplication of capability in the HEC software suite.

## ***Model Formulation***

All of the mathematical models included in the program are deterministic. This means that the boundary conditions, initial conditions, and parameters of the models are assumed to be exactly known. This guarantees that every time a simulation is computed it will yield exactly the same results as all previous times it was computed. Deterministic models are sometimes compared to stochastic models where the same boundary conditions, initial conditions, and parameters are represented with probabilistic distributions. Plans are underway to develop a stochastic capability through the addition of a Monte Carlo analysis tool.

All of the mathematical models included in the program use constant parameter values, that is, they are assumed to be time stationary. During long periods of time it is possible for parameters describing a watershed to change as the result of human or other processes at work in the watershed. These parameter trends cannot be included in a simulation at this time. There is a limited capability to break a long simulation into smaller segments and manually change parameters between segments. Plans are underway to develop a variable parameter capability, through an as yet undetermined means.

All of the mathematical models included in the program are uncoupled. The program first computes evapotranspiration and then computes infiltration. In the physical world, the amount of evapotranspiration depends on the amount of soil water. The amount of infiltration also depends on the amount of soil water. However, evapotranspiration removes water from the soil at the same time infiltration adds water to the soil. To solve the problem properly the evapotranspiration and infiltration processes should be simulated simultaneously with the mathematical equations for both processes numerically linked. At this time the program computes evapo-transpiration and infiltration in a loosely coupled arrangement and consequent errors due to the limited coupling are minimized as much as possible by using a small time interval for calculations. While preparations have been made to support the inclusion of fully coupled plant-surface-soil models, none have been added at this time.

## ***Flow Representation***

The design of the basin model only allows for dendritic stream networks. The best way to visualize a dendritic network is to imagine a tree. The main tree trunk, branches, and twigs correspond to the main river, tributaries, and headwater streams in a watershed. The key idea is that a stream does not separate into two streams. The basin model allows each hydrologic element to have only one downstream connection so it is not possible to split the outflow from an element into



two different downstream elements. The diversion element provides a limited capability to remove some of the flow from a stream and divert it to a different location downstream in the network. Likewise, a reservoir element may have an auxiliary outlet. However, in general, branching or looping stream networks cannot be simulated with the program and will require a separate hydraulic model which can represent such networks.

The design of the process for computing a simulation does not allow for backwater in the stream network. The compute process begins at headwater subbasins and proceeds down through the network. Each element is computed for the entire simulation time window before proceeding to the next element. There is no iteration or looping between elements. Therefore, it is not possible for an upstream element to have knowledge of downstream flow conditions, which is the essence of backwater effects. There is a limited capability to represent backwater if it is fully contained within a reach element. However, in general, the presence of backwater within the stream network will require a separate hydraulic model.

## ***Documentation Conventions***

The following conventions are used throughout the manual to describe the graphical user interface:

- Screen titles are shown in *italics*.
- Menu names, menu items, and button names are shown in **bold**.
- Menus are separated from submenus with the right arrow ⇒.
- Data typed into an input field or selected from a list is shown using the `courier` font.
- A column heading, tab name, or field title is shown in "double quotes".

## ***References***

Corps of Engineers. 1952. Engineer Manual 1110-2-1411: Standard Project Flood Determinations. U.S. Army, Washington, DC.

Hydrologic Engineering Center. June 1998. HEC-1 Flood Hydrograph Package: User's Manual. U.S. Army Corps of Engineers, Davis, CA.

Hydrologic Engineering Center. April 1992. HEC-IFH Interior Flood Hydrology Package: User's Manual. U.S. Army Corps of Engineers, Davis, CA.

Hydrologic Engineering Center. November 1989. Water Control Software: Forecast and Operations. U.S. Army Corps of Engineers, Davis, CA.

National Weather Service. 1961. Technical Paper 40: Rainfall Frequency Atlas for the United States for Durations from 30 Minutes to 24 Hours and Return Periods from 1 to 100 Years. U.S. Department of Commerce, Washington, DC.

National Weather Service. 2004. NOAA Atlas 14 Precipitation-Frequency Atlas of the United States: Volume 1 Semi Arid Southwest (Arizona, Southeast California, Nevada, New Mexico, Utah). U.S. Department of Commerce, Silver Spring, MD.

National Weather Service. 2004. NOAA Atlas 14 Precipitation-Frequency Atlas of the United States: Volume 2 Delaware, District of Columbia, Illinois, Indiana, Kentucky, Maryland, New Jersey, North Carolina, Ohio, Pennsylvania, South Carolina, Tennessee, Virginia, West Virginia. U.S. Department of Commerce, Silver Spring, MD.

National Weather Service. 1973. NOAA Atlas 2: Precipitation-Frequency Atlas of the Western United States. U.S. Department of Commerce, Silver Spring, MD.

Soil Conservation Service. 1986. Technical Release 55: Urban Hydrology for Small Watersheds. Department of Agriculture, Washington, DC.

## CHAPTER 2

# ***Installing and Running the Program***

This chapter describes the recommended computer system requirements for running the program. Step-by-step installation procedures are also provided for the three operating systems that are supported.

### ***Operating System Requirements***

The program has been created using the Java programming language. Programs written in the language can run on almost any operating system. However, several libraries used by the program are still in the FORTRAN language. These libraries are currently only available for the Microsoft Windows and Linux operating systems. This means that the program itself is also only available for those operating systems. Nevertheless, because the program was created with the Java language, the program looks and behaves substantially the same on all operating systems.

The program is available for:

- Windows XP, Windows Vista, and Windows 7 (32-bit and 64-bit).
- Modern Linux x86 distributions.

The program has been extensively tested on Windows XP and RED HAT Enterprise Linux 4.

### ***Hardware Requirements and Recommendations***

The typical hardware equipment for the Microsoft Windows or Linux installation includes:

- Intel Pentium III/800 MHz or higher (or compatible).
- 512 MB of memory minimum.
- 1 GB of memory recommended.
- 120 MB of available hard disk space for installation.
- 1024x768 minimum screen resolution.

Significantly more resources may be needed depending on your application. The minimum equipment for either operating system will be suitable for event simulation with basin models containing only 20 or 30 hydrologic elements. However, you will need better equipment if you intend to build basin models with over a hundred elements, perform continuous simulation for long time windows, or use the ModClark gridded transform method. For intense applications you should consider a multiple processor system running at 2.0 GHz or faster, and 1 GB or more of physical memory.

## **Installation**

Installation packages for the program are available from the Hydrologic Engineering Center (HEC) website where the current version of the program is always available. Old versions of the program are archived and can be downloaded. However, old versions are not maintained, contain bugs and errors, and may not function correctly with current versions of the supported operating systems.

### **Microsoft Windows Operating System**

You must obtain the installer before you can setup the program on your computer. If you have access to the internet, the installer can be downloaded directly from the HEC website at [www.hec.usace.army.mil](http://www.hec.usace.army.mil). If you do not have access to the internet then you must obtain a copy on removable media such as a CD-ROM disk.

In order to run the installer you must have Administrator privileges on your computer. You only need the privileges during installation; once installation is complete the program can run successfully without Administrator privileges. If you do not have Administrator privileges, the installer will notify you and quit. Please contact your system administrator for assistance during installation.

After you have obtained the installer and Administrator privileges, use the following steps to install the program:

1. Run the HEC-HMS 4.2 Setup Package downloaded from the HEC website.
2. Depending on your security settings, you may receive a warning before the installer starts. The installer is signed with a digital signature so you can verify it was produced by HEC and has not been altered. If the digital signature is OK, press the **Run** button to proceed with starting the installer.

3. The installer will open in a new window and perform some preliminary configurations in preparation for installation. A welcome window will notify you that HEC-HMS 4.2 will be installed. Press the **Next** button to continue with the installation.
4. The next window will display the terms and conditions for using the program. This must be accepted during installation and later by every user who starts using the program on the computer where it is installed. Please read the terms and conditions for use carefully. If you agree, click the "I agree to the above Terms and Conditions for Use" radio button, and then press the **Next** button. If you do not agree, the installer will exit without installing the program.
5. The next window is used to select the location where the program will be installed on the local disk. It is recommended that the default location in the C:\Program Files folder be used. Press the **Next** button when you are satisfied with the installation location.
6. The next window allows you to choose if a shortcut to the program will be placed on the desktop. Program shortcuts will automatically be created in the **Start** menu under the **All Programs** ⇒ **HEC** folder, so having a desktop shortcut is optional.
7. The next and final window allows you to confirm that you are ready for installation. If you would like to change any of the previously configured settings, you may use the **Back** button. Press the **Install** button to install the program with all of the configuration information specified in the previous windows.

The installer will copy all necessary files and make additional configuration changes to the operating system. You do not need to restart the computer after the installation completes. At any time you can uninstall the program through the *Control Panel*. When future versions of the program become available, you may have each version separately installed on your computer.

### ***Linux Operating System***

You must obtain the installer before you can setup the program on your computer. If you have access to the internet, the installer can be downloaded directly from the HEC website at [www.hec.usace.army.mil](http://www.hec.usace.army.mil). If you do not have access to the internet then you must obtain a copy on removable media such as a CD-ROM disk.

The installation program for this operating system is run from the command line, so terminal access is required. If you would like to install the program for all users of the system, you will need root access during the installation. Otherwise, the program package can be installed into any user writable directory on the system and be run from that location. The program does not require root privileges to run. In general, the changes required to install on this operating system require the skills of a system administrator. Please contact your system administrator to install the program for you if you're unsure how. You may need to refer your administrator to this section of the manual.

After you have obtained the install package and proper permissions, use the following steps to install the program:

1. Download hechms42.bin to your Linux box. Keep note where you put it. In the example below, we put it into /tmp.
2. Change directory to the location where you want to install the HEC-HMS 4.2 program files.

```
cd <location where HEC-HMS 4.2 is to be installed>
```

3. Change the permissions of the installer to allow execution:

```
chmod +x </tmp>/hechms42.bin
```

4. Run hechm42.bin:

```
</tmp>/hechms42.bin
```

5. You will be presented with the Terms and Conditions for use of HEC-HMS. Read the TCU and then type in "yes" if you agree.
6. Once you have accepted the TCU, HEC-HMS 4.2 will be extracted to <current working directory>/hechms42.

HEC-HMS 4.2 is now installed. When future versions of the program become available, you may have each version separately installed on your computer. You will need to carefully organize the installation locations so that each version can be kept separate.

## ***Running the Program***

The Windows version of the program is designed to be installed only once on a computer, and shared by every user with logon access to the computer. On Linux the program can be installed by Root in a single location for use by all users of the system, or each user can install it in their own home directory. Program configuration information is stored separately for each user. Projects will also be stored

separately for each user, unless the users take steps to make the projects available to all users.

### **Microsoft Windows Operating System**

Run the program by clicking on the **Start** menu and then place the mouse over the **All Programs** selection. After a short hesitation, the list of available programs will be displayed. Move the mouse to the **HEC** folder and move to the **HEC-HMS** subfolder. Click on the version of the program you wish to run.

If you chose to add a desktop shortcut during installation, you can also run the program directly from the desktop. An icon will be shown on the desktop for the program. Move the mouse over the icon and double-click the left mouse button.

### **Linux Operating System**

Run the program by changing directory to the directory where the program is installed and then executing the hms script:

```
cd <HEC-HMS Install>
./hms
```

If you would like to run HEC-HMS 4.2 from any location on your file system without changing directory to the install location first, you must make a change to the hms script. There is a variable defined in the script called HMS\_HOME which specifies where HEC-HMS is installed. By default, it is set to the current directory ("."). Change that variable to the fully qualified path of where HEC-HMS 4.2 installed.

After changing the script to reflect the full path to the program install directory, you need to modify the PATH variable to include the program directory:

```
set path = ($path <HEC-HMS Install>)
```

where <HEC-HMS Install> is replaced with the installation directory name. Once your path is set to include the HEC-HMS installation directory, then you can simply type "hms" from anywhere on the system to run program.

## **Command Line Operation**

The normal mode of operation starts the program and displays the interface. From the interface the user can access all the features and capabilities of the program using the mouse and keyboard. However, for some uses it may advantageous to start the program, have it carry out certain commands, and then shut down. There is a very limited

capability to operate in this mode using scripting control. Additional scripting capabilities may be added in the future.

The first step is to create a control script. It is best if the simulation that will be computed by the script already exists and has been tested in normal operation to make sure it completes successfully. A typical script would contain the following lines in a file:

```
from hms.model.JythonHms import *
OpenProject("Tenk", "C:\\hmsproj\\Tenk")
Compute("Run 1")
Exit(1)
```

Once you have created the script file, it can be used with the program from the command line. The program will start and automatically process the script. The first line is used to setup the scripting environment and make the program data model accessible to the script. The second line opens an existing project and the third line computes an existing simulation run. The final line of the script exits the program.

To use a script on the Microsoft Windows® operating system, begin by opening a command window and changing directories to the installation folder. The installation folder is not standardized and depends on where you chose to install the program. One possibility would look like the following:

```
C:\Program Files\HEC\HEC-HMS\4.2>
```

At the command prompt, type the following to launch the program and run the script, where the last argument is the complete path to a script:

```
hec-hms.cmd -s C:\hmsproj\Tenk\compute.script
```

To use a script on the Linux operating system, begin by opening a console and changing directories to the installation folder. The installation folder is not standardized and depends on the policies of your system administrator. One possibility would look like the following:

```
/usr/hec/hechms>
```

At the console, type the following to launch the program and run the script, where the last argument is the complete path to the script:

```
hms -s /usr/smith/hmsproj/tenk/compute.script
```

The program will not be visible while it is running the script. However, the commands in the script will be carried out. Any messages generated while computing the simulation run will be written to the log



file. All results will be stored in the output Data Storage System (DSS) file. Inspection of the log file will reveal any errors, warning, or notes and results can be read from the DSS file.

## ***Managing Memory Allocation***

The program defaults to using up to 512 MB of memory. This is sufficient for most common applications of the program. However, simulations with basin models that include many elements, use long time windows for continuous simulation, or make use of gridded meteorology can require significantly more memory. Computing large simulations with insufficient memory may cause the program to abruptly cease operation.

The following files need to be changed to allow the program to use more memory than the default 512 Mb:

Windows:

```
<HEC-HMS Install>\HEC-HMS.cmd  
<HEC-HMS Install>\HEC-HMS.config
```

Linux:

```
<HEC-HMS Install>/hms
```

In all three files, search for the string `-Xmx512M` and replace the 512 with the number of MB's you would like to allow the program to use.

The amount of memory you can use depends on your operating system. A typical computer using Microsoft Windows® or Linux® can usually use up to 1,350 Mb. These are general guidelines and your situation will depend on the specifics of your hardware and other processes that may be executing at the same time as the program. In no case should you attempt to use more than half of the physical memory in the machine since other applications and system processes also require memory resources.

## ***Additional Resources***

The program includes an online help system that is automatically installed when the program is installed. The help system is equivalent to the User's Manual, Technical Reference Manual, and Applications Guide. The various documents are also available separately.

Three sample projects are included with the program. The "Castro" project shows how the program can be used for basic hydrology. The "Tenk" project demonstrates the capability of the program to use gridded precipitation. Finally, the "Tifton" project exhibits continuous simulation with the soil moisture accounting method. The projects are

kept in a space-saving, compressed form. They can be extracted for use at any time by going to the **Help** menu and selecting the **Install Sample Projects...** command.

---

## CHAPTER 3

# Overview

This chapter describes the basics of working with the program. It includes descriptions of the main parts of the interface. Specific details of when and how data are saved is also included. Conventions are provided for the formatting of input data, the use of units, and interpolation. An outline of the best way to use the program is also provided.

## Program Screen

The program screen contains a title bar, menu system, toolbar, and four panes. These panes will be referred to as the *Watershed Explorer*, *Desktop*, *Component Editor*, and the *Message Log* as shown in Figure 1. The title bar displays the version of the program used and the location of the currently-open project. The other parts of the program screen are discussed in detail in this chapter.

## Menu System

The menu system contains several menus to help you use the program. Each menu contains a list of related commands. For example, the **Parameters** menu contains a list of commands to open global parameter tables for viewing and editing parameters required by hydrologic elements in the selected basin model. Items in an individual menu are inactive (cannot be selected) if the command can not be carried out by the program at the current time.

Commands for managing the opened project are available from the **File** menu. **File** menu items and the resulting actions are provided in Table 1. The last four projects opened are shown at the bottom of the **File** menu. Click on one of the project names to open the project.

The **Edit** menu contains commands for editing hydrologic elements in the selected basin model. If no basin model is selected, then all commands in this menu are inactive. **Edit** menu commands and the resulting actions are provided in Table 2. Additional **Edit** menu includes commands select mouse tools for use in the *Basin Model Map*.

The **View** menu contains a list of commands for working in the basin map. These commands are inactive if no basin model is open in the

**Desktop.** A list of **View** menu items and the resulting actions are provided in Table 3.

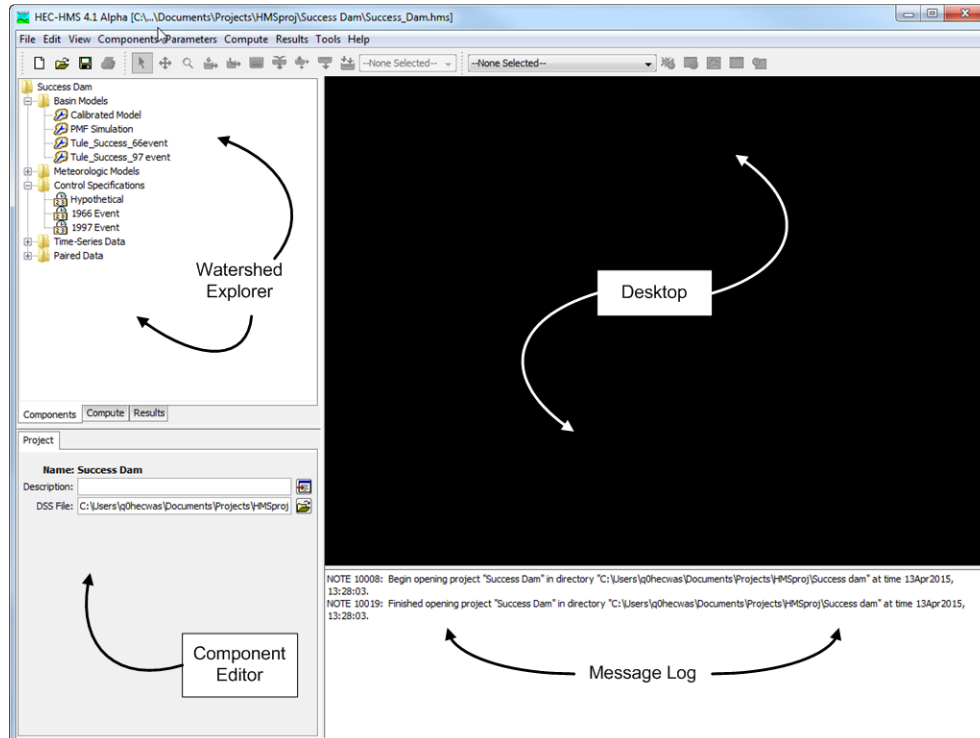

Figure 1. The main program screen with Watershed Explorer in the upper left, Component Editor in the lower left, Message Log at the bottom, and Desktop using the remaining area.

Table 1. Commands available from the File menu.

File Menu Commands	Action
<b>New...</b>	Create a new project.
<b>Open...</b>	Open a project.
<b>Import ⇒</b>	Import HEC-1 files and components.
<b>Save</b>	Save the current project.
<b>Save As...</b>	Make a copy of the current project.
<b>Delete</b>	Delete the current project.
<b>Rename</b>	Rename the current project.
<b>Backup...</b>	Create a backup copy of the current project, or restore from a backup.
<b>Print...</b>	Print the currently selected item.
<b>Exit</b>	Exit the program.

Table 2. *Commands available from the Edit menu.*

<b>Edit Menu Commands</b>	<b>Action</b>
<b>Cut</b>	Cut or delete the selected hydrologic element(s).
<b>Copy</b>	Make a copy of the selected hydrologic element(s).
<b>Paste</b>	Paste the copied hydrologic element(s).
<b>Select All</b>	Select all hydrologic elements in the basin model.
<b>Clear Selection</b>	Unselect all selected hydrologic elements in the basin model.
<b>Select Special...</b>	Open the Select Special dialog.

Table 3. *Commands available from the View menu.*

<b>View Menu Commands</b>	<b>Action</b>
<b>Maximum Extents</b>	Open the maximum extents editor.
<b>Background Maps</b>	Open the map layer selector editor.
<b>Draw Gridlines</b>	Toggle showing gridlines in the basin map.
<b>Zoom In</b>	Zoom in by a factor of 25%.
<b>Zoom Out</b>	Zoom out by a factor of 50%.
<b>Zoom To Selected</b>	Zoom to the current element selection.
<b>Zoom To Maximum Extents</b>	Zoom out to the maximum extents.
<b>Draw Element Icons</b>	Toggle showing of element icons .
<b>Draw Map Objects</b>	Toggle showing of element polygons and polylines.
<b>Draw Element Labels</b>	Toggle showing of labels in different formats .
<b>Draw Flow Directions</b>	Toggle flow direction arrows on reach elements.
<b>Rescale Elements</b>	Scale the locations of the selected elements.
<b>Lock Element Locations</b>	Toggle allowing element locations to be changed.
<b>Lock Hydrologic Order</b>	Toggle allowing sorting and reordering.
<b>Clear Messages</b>	Clear all messages from the message window.

Table 4. Commands available from the Components menu.

Components Menu Commands	Action
<b>Basin Model Manager</b>	Open the basin model manager.
<b>Meteorologic Model Manager</b>	Open the meteorologic model manager.
<b>Control Specifications Manager</b>	Open the control specifications manager.
<b>Time-Series Data Manager</b>	Open the time-series data manager.
<b>Paired Data Manager</b>	Open the paired data manager.
<b>Grid Data Manager</b>	Open the grid data manager.

Component managers are opened from the **Components** menu. Program components include basin models, meteorologic models, control specifications, time-series data, paired data, and gridded data. A list of **Components** menu items and the resulting actions are provided in Table 4.

The **Parameters** menu contains menu commands to open global parameter editors. Global parameter editors let you view and edit subbasin and reach parameters for elements using the same methods (subbasin canopy, surface, loss, transform, and baseflow methods and reach routing and gain/loss methods). Global parameter menu options are only active if subbasin or reach elements in the basin model use the method. For example, if the **Parameter** ⇒ **Loss** menu option is selected, a submenu with all loss methods opens. Only loss methods used by subbasin elements in the current basin model will be active in the menu. If hydrologic elements are selected in the basin model, then the selected elements determine what menu items are available. The **Parameters** menu also contains menu commands to change subbasin canopy, surface, loss, transform, and baseflow methods and reach routing and gain/loss methods. If subbasin or reach elements are selected in the basin model, then only the selected elements will change methods. The last menu command on the **Parameters** menu is **Element Inventory**. This command lets you view a table of all hydrologic elements in the basin model. If elements are selected, then only the selected elements will be included in the table.

The **Compute** menu contains a list of commands for creating, computing, and managing simulation runs, optimization trials, analyses, and forecast alternatives. A list of **Compute** menu items and the resulting actions are provided in Table 5. Menu commands for creating simulation runs, optimization trials, forecast alternatives, depth-area analyses and uncertainty analyses are only enabled with

the necessary underlying components have been created. The **Compute** command is only enabled when a compute item is selected.

The **Results** menu contains a list of commands for viewing results from hydrologic elements in a basin model. Three cases must be met before commands from the **Results** menu are active:

1. A simulation run, optimization trial, analysis, or forecast alternative must be selected.
2. A hydrologic element or elements must be selected.
3. The results for the simulation must be available.

Results for a simulation are available as long as the simulation computed successfully and no changes were made by the user to components used by the simulation after it was computed. If you change parameter data, like values in a paired data table used by a reach element for modified-Puls routing, then the simulation must be recomputed. A list of **Results** menu items and the resulting actions are provided in Table 6.

*Table 5. Commands available from the Compute menu.*

<b>Compute Menu Commands</b>	<b>Action</b>
<b>Create Compute</b>	Open a wizard to create a new simulation from among the five types.
<b>Simulation Run Manager</b>	Open the simulation run manager to create, copy, rename, or delete runs.
<b>Optimization Trial Manager</b>	Open the optimization trial manager.
<b>Forecast Alternative Manager</b>	Open the forecast alternative manager.
<b>Depth-Area Analysis Manager</b>	Open the depth-area analysis manager.
<b>Uncertainty Analysis Manager</b>	Open the uncertainty analysis manager.
<b>Run Calibration Aids</b>	When a run is selected, opens the calibration aids at a computation point.
<b>Forecast Initial Baseflow</b>	When a forecast is selected, choose observed flow for automatically initializing subbasin baseflow
<b>Forecast Parameter Adjustments</b>	When a forecast is selected, opens the editor for loss rate and other adjustments.

Table 5. Continued.

<b>Compute Menu Commands</b>	<b>Action</b>
<b>Forecast Slider Adjustments</b>	When a forecast is selected, choose parameter adjustments for control by a slider.
<b>Forecast Slider Settings</b>	When a forecast is selected, sets boundary range for each slider.
<b>Forecast Reservoirs</b>	When a forecast is selected, choose observed stage for automatically initializing and adjusting reservoir storage.
<b>Forecast Blending</b>	When a forecast is selected, opens the editor for observed flow blending.
<b>Multiple Compute</b>	Compute multiple simulations.
<b>Compute</b>	Compute the selected simulation.

Table 6. Commands available from the Results menu. Items marked with (1) are available for simulations runs, items with (2) are available for optimization trials, and items with (3) are available for depth-area analyses.

<b>Results Menu Commands</b>	<b>Action</b>
<b>Global Summary Table<sup>1</sup></b>	Open a summary table containing all hydrologic elements in the basin model.
<b>Objective Function summary<sup>2</sup></b>	Objective function value and statistics.
<b>Optimized Parameters<sup>2</sup></b>	Optimized parameter values.
<b>Hydrograph Comparison<sup>2</sup></b>	Comparison of computed and observed hydrographs.
<b>Flow Comparison<sup>2</sup></b>	Computed versus observed flow values.
<b>Flow Residuals<sup>2</sup></b>	Residual between computed and observed values.
<b>Objective Function<sup>2</sup></b>	Objective function value by iteration.
<b>Peak Flow Table<sup>3</sup></b>	Peak flow at analysis points.
<b>Element Graph</b>	Open a graph of results for the current selection.
<b>Element Summary Table</b>	Open a summary table for the current selection.
<b>Element Time-Series Table</b>	Open a time-series table for the current selection.
<b>Graph Properties</b>	Change the line styles, symbols, and other properties of the selected graph.



The **Tools** menu offers a list of specialized commands. A list of **Tools** menu items and the resulting actions are provided in Table 7. Additional tools will be added to the menu in a future program version.

The **Help** menu provides links to the online help system. The sample projects can be installed from this menu. You may also access the terms and conditions for using the program, and information about the program and development team; this information is helpful when reporting program problems.

Table 7. *Commands available from the Tools menu.*

<b>Tools Menu Commands</b>	<b>Action</b>
<b>Reports</b> ⇒	Generate reports of basin model or simulation run results using a custom template.
<b>Delete Results</b>	Delete time-series results for simulations.
<b>Squeeze Output File</b>	Remove space used by deleted results.
<b>Program Settings</b>	Change properties for the program.

### **Toolbar**























Like the menu system, the toolbar groups tools with similar uses. Also, tools are inactive if the resulting action for the tool can not be carried out by the program. Table 8 contains a description of tools on the toolbar.

### **Watershed Explorer**

The *Watershed Explorer* was developed to provide quick access to all components and simulations in a project. For example, the user can easily navigate from a basin model to a precipitation gage and then to a meteorologic model without using menu commands or opening additional windows. The *Watershed Explorer* is divided into three parts: Components, Compute, and Results.

A typical view of the "Components" tab of the *Watershed Explorer* is shown in Figure 2. The hierarchal structure of model components, such as basin models, meteorologic models, etc., is available from the "Components" tab. The *Watershed Explorer* organizes model components into individual folders. If all component types were in a project, then the Components tab would contain six main folders, Basin Models, Meteorologic Models, Control Specifications, Time-Series Data, Paired Data, and Grid Data. The *Watershed Explorer* expands when one of these main component folders is selected. When a component in a main folder is selected, the *Watershed Explorer* expands even more to show sub-components. For example, when the

Table 8. Description of the tools in the toolbar.

Tool	Action
	Create a new project.
	Open an existing project.
	Save the current project.
	Print the selected item in the <i>Desktop</i> (basin map or result window).
	Select hydrologic elements in the basin map.
	Pan in the basin map.
	Zoom in or out in the basin map.
	Add a subbasin element to the basin map.
	Add a reach element to the basin map.
	Add a reservoir element to the basin map.
	Add a junction element to the basin map.
	Add a diversion element to the basin map.
	Add a source element to the basin map.
	Add a sink element to the basin map.
	Compute the currently selected simulation run.
	Compute the currently selected optimization trial.
	Compute the currently selected forecast alternative.
	Compute the currently selected depth-area analysis.
	Compute the currently selected uncertainty analysis.
	Open global summary table.
	Open graph for the current element selection.
	Open summary table for the current element selection.
	Open time-series table for the current element selection.

Basin Models folder is selected, the *Watershed Explorer* expands to show all basin models in the project. The *Watershed Explorer* will expand again to show all hydrologic elements in a basin model when a basin model is selected. Notice in Figure 2 that the Castro 1 basin

model is selected and the *Watershed Explorer* is expanded to show all hydrologic elements in the basin model. The plus/minus sign beside model components and sub-components can be used to expand or collapse the *Watershed Explorer*. The "Compute" tab of the *Watershed Explorer* contains all project simulation runs, optimization trials, analyses, and forecast alternatives. Model results are available from the "Results" tab of *Watershed Explorer*.

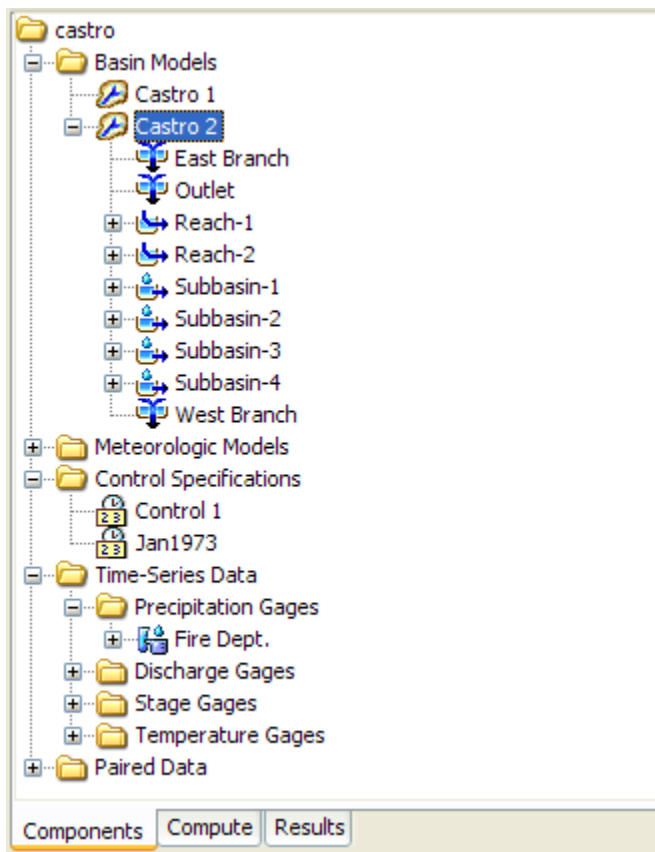

Figure 2. *Watershed Explorer* showing the "Components" tab with all of the different component types.

## Desktop

The *Desktop* holds a variety of windows including global parameter editors, and most importantly the basin map. Result windows including graphs, summary tables, and time-series tables can be shown in the *Desktop*, or optionally, outside the *Desktop*. All other windows cannot be moved outside of the *Desktop* area. The basin map is used to develop a basin model. Hydrologic elements (subbasin, reach, reservoir, etc.) are added from the toolbar and connected to represent the physical drainage network of the study area. Background maps can be imported to help visualize the watershed. The Castro 1 basin map is shown in Figure 3.

## Component Editor

When a component or sub-component in the *Watershed Explorer* or hydrologic element in the basin map is active (use the mouse and click on the component name in the *Watershed Explorer* or select the hydrologic element in the basin map), a specific component editor will open. Data for model components is entered in the *Component Editor*. Required data is indicated with a red asterisk. For example, loss parameter data for a subbasin element is entered in the *Component Editor* for the subbasin. The *Component Editor* for the Castro 1 basin model is shown in Figure 4.

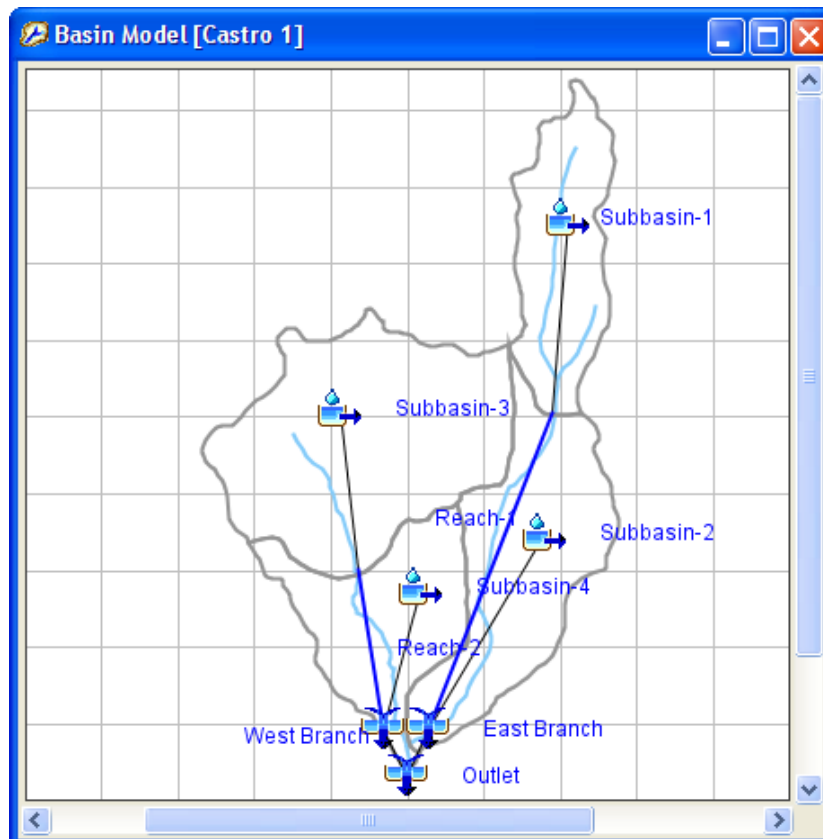

Figure 3. Basin map for a basin model named Castro 2. The basin map is shown in the Desktop area of the program screen.

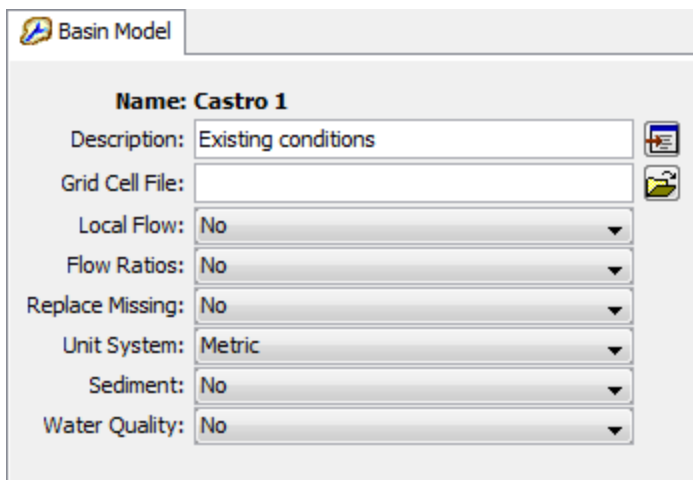

Figure 4. A basin model component editor showing the name, description, and other parameter data.

## Message Log

Notes, warnings, and errors are shown in the *Message Log*, as seen in Figure 5. These messages are useful for identifying why a simulation run failed or why a requested action, like opening a project, was not completed.

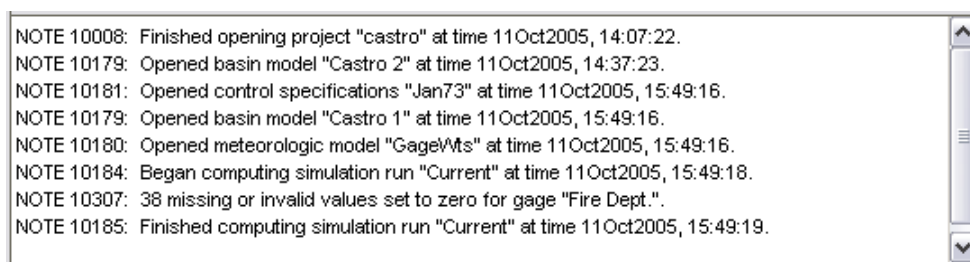

Figure 5. Message Log showing recent messages generated while computing a simulation run.

## Program Settings

Additional program settings are available. Click the **Tools** menu and select the **Program Settings** command to access the *Program Settings* window. This window allows you to change any of the optional settings as shown in Figure 6.

The "General" tab contains a number of settings for the general behavior of the program. This includes details such as how much warning you want before making irreversible changes in modeling components, where to display global editors, a display option for the decimal separator, language for displaying calendar dates, and a display option for latitudes and longitudes.

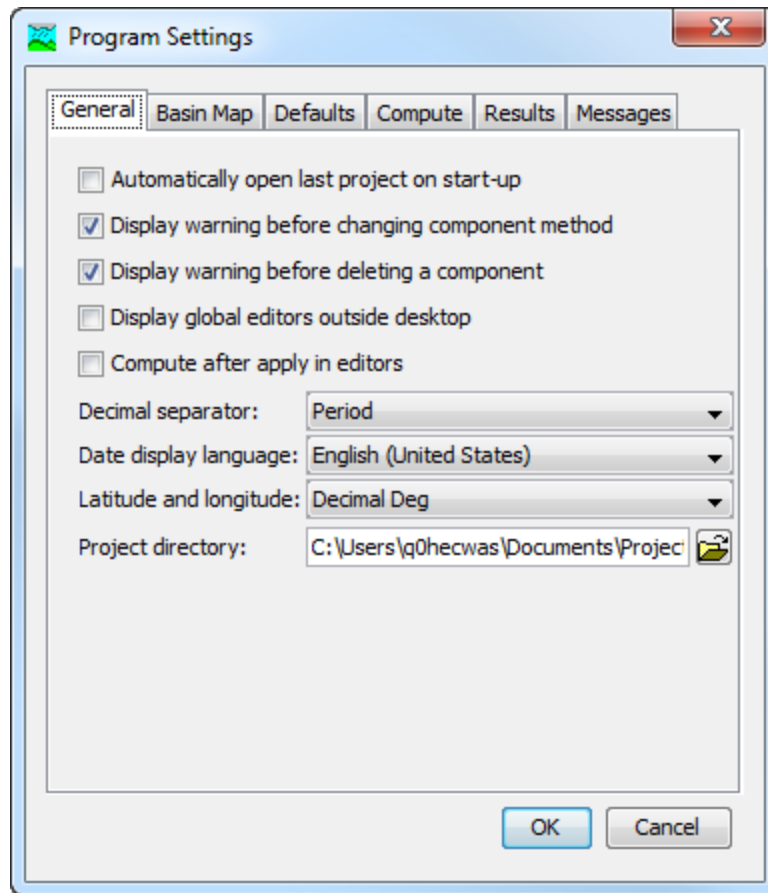

Figure 6. Changing program settings.

The "Basin Map" tab contains settings for the basin map window. The settings include the option to automatically recenter the map when selecting an element. The selection highlight color and the grid line color can also be selected.

The "Defaults" tab contains settings for the default unit system, subbasin component methods, and reach component methods. These are the settings that will be used when new components are created. You can always change the setting after the component is created.

The "Compute" tab contains settings for closing the compute progress if the compute is successful and other details of how a compute is performed. Importantly, the buffer length controls how much memory is required during a compute. When the length is set to a large value, the compute is optimized for speed but may exhaust available memory. When the length is set to a small value, very large computes (large number of elements or very long time windows) can be completed but the speed may be slower.

The "Results" tab contains a number of settings for managing simulations and the results that are produced. Control is provided for

supplemental results that give extra information but are not critical to the simulation, output of gridded results when using the ModClark transform method, and the location to display results. Finally, you can specify the number of decimal digits to use when displaying different categories of results.

The "Messages" tab contains settings for the error, warning, and note messages. You can select whether a sound is played when a particular type of message occurs. You can also choose the color that is used to print the message in the *Message Log*.

## **Data Conventions**

The program must manage many different kinds of data that are part of a wide variety of components. Part of the management is the saving and display of the data entered by the user. The remainder of the management is the use of the data during a compute.

### ***Saving Properties***

The program uses the concept of the current component to manage saving updates or changes to properties. The current component is the item in the project that is currently selected in the *Watershed Explorer*. For example, if you click on a subbasin icon in the *Watershed Explorer* it will become highlighted, and its editor will be shown in the *Component Editor*. The subbasin becomes the current component at that moment. You may make changes to the properties of the subbasin on any of the tabs in the *Component Editor*. When you switch between tabs, any changes are automatically updated in the subbasin. The changes are also updated when you leave the tabs and click anywhere else in the program interface. Even though the updates are made in the subbasin properties, the changes are not saved to disk. Updates and changes are only saved to disk when the project is saved. You can save the project two different ways.

The first way to save all pending changes is from the **File** menu. Click on the **File** menu and then select the **Save** command. All components currently open in the project will be saved to disk, including the current basin model with its hydrologic elements, current meteorologic model, current control specifications, and all other project components.

The second way to save all pending changes is from the toolbar. Click the **Save Current Project** button. All components in the project will be saved to disk.

## **Number Formatting**

Each country of the world has socially accepted conventions for formatting numbers. It would be difficult for the program to support every single convention in use around the world. However, one important factor is the symbol used for the decimal separator. For example, in the United States a number would typically be formatted as follows:

12.34

In Austria the same number would usually be displayed as follows:

12,34

Either format can be selected using the program settings described in [Chapter 3](#). The setting is used to interpret all user input and to configure all displayed output data.

## **Date and Time Formatting**

The formatting of dates and times is also subject to social convention. The program imposes some limitations to simplify the formatting of date and time information. All dates should specify a two-digit day, followed by the month abbreviation, and end with a four-digit year. For example, in the United States a date would be entered or displayed as follows:

07Feb2004

The same date would be entered or displayed in France as follows:

07févr.2004

Dates will be processed using the common month abbreviation according to the language and country selected in the program settings described in [Chapter 3](#). The selected choice will be used for displaying data information, for example, in computed results. The selected choice will also be used for interpreting input, for example, when specifying the start time of a simulation.

All times are formatted with the same rules regardless of any settings on the computer. A time should use two digits for the hour, followed by a colon, and end with two digits for the minutes. All times are assumed to be in an arbitrary local time zone that does not observe summer time (daylight savings in the United States). It uses 24-hour clock time instead of AM or PM notation. For example, time would always be displayed as:

14:25



Some status messages displayed by the program indicate when some event occurred. Those times also include seconds.

The date system used in the program follows the Gregorian calendar. This calendar entered use at the end of the day on 04 October 1582. It took many years for the calendar to gain wide-spread use in Europe. It eventually became the most common calendar in use around the world. One of the principal features of the calendar is the definition of leap year. Because the program does not implement the calendars that preceded it, the leap year rules defined in the Gregorian calendar are applied throughout all time. This means that for simulations with time intervals before 1582, the simulation results may show inconsistencies when compared to the calendar actually in use during those ancient historical times.

### ***Units Conversion***

Almost all initial conditions and parameter data for the various methods included in the program require units. For example, hydraulic conductivity has units of either millimeters per hour (mm/hr) or inches per hour (in/hr) depending on the unit system of the basin model. The unit system is one of the properties of the basin model and meteorologic model. If the system international unit system is selected for a basin model, then the hydraulic conductivity should be entered in mm/hr. However, the conductivity should be entered in in/hr if the U.S. customary unit system is selected. The units of an initial condition or parameter are shown in parenthesis after the label.

The value of initial conditions and parameter data are automatically converted when the unit system of a basin model or meteorologic model is changed. For example, suppose a basin model used the U.S. customary unit system and a hydraulic conductivity was entered as 0.23 in/hr. If the unit system were changed to system international, the conductivity would be automatically converted to 5.84 mm/hr. The conversions are performed according to standards specified by the National Institutes of Standards and Technology (Taylor 1995).

Time-series data, paired data, and grid data components each have their own unit system based on the units of the data. The unit system is determined automatically from the units of the data. For example, a discharge time-series gage with units of cubic meters per second (M<sup>3</sup>/S) will be in the system international unit system. The units are selected by the user for manual entry data, but are read automatically from the record header for external DSS data. Data is automatically converted to the correct unit system during a compute.

## ***Interpolation***

Time-series data and gridset data are usually defined with a fixed time interval, though some data may be defined on an irregular basis. All of the different types of simulations happen with a fixed time interval, as specified in the control specifications. When the time interval of the time-series or gridset data does not match the time interval of the compute, the data is automatically interpolated. A linear interpolation in time is used.

Paired data components use a limited number of points to represent a curve, such as a storage-discharge curve. However, the curve represents continuous data. Linear interpolation is used when a dependent value is required for an independent value between two specified values. The interpolation is performed between the dependent values corresponding to the closest available independent values on each side of the requested value. Some paired data components use irregularly spaced values to represent an annual pattern, such as a groundmelt pattern. Linear interpolation in time is used on these components.

## ***Application Steps***

The program is designed with reusable data sets that can be independently developed. However, some data sets depend on others for important definitions. For example, gages must be created before they can be used in basin or meteorologic models. Consequently, there is a necessary sequence to successfully obtain results. The remainder of this chapter provides an overview of the best procedure for obtaining computation results.

### ***Create a New Project***

Create a new project by selecting the **File** ⇒ **New...** menu command. After you press the button a window will open where you can name, choose a location on your computer or a network computer to save the new project, and enter a description for the new project. If the description is long, you can press the button to the right of the description field to open an editor. You should also select the default unit system; you can always change the unit system for any component after it is created but the default provides convenience. Press the **Create** button when you are satisfied with the name, location, and description. You cannot press the **Create** button if no name or location is specified for the new project. If you change your mind and do not want to create a new meteorologic model, press the **Cancel** button or the **X** button in the upper right of the *Create a New Project* window.

## ***Enter Shared Project Data***

Shared data includes time-series data, paired data, and grid data. Shared data is often required by basin and meteorologic models. For example, the meteorologic model typically requires precipitation observations. In another example, a reach element using the Modified-Puls routing method requires a storage-discharge relationship for the program to calculate flow through the reach. Finally, a subbasin using the ModClark transform requires soil parameters for each grid cell. Table 9 contains a complete list of shared data types used by the program.

All of the different types of time-series data:

- Precipitation
- Discharge
- Stage
- Temperature
- Radiation
- Windspeed
- Air pressure
- Humidity
- Altitude
- Crop coefficient
- Snow water equivalent
- Sediment load
- Concentration
- Percent
- Evapotranspiration
- Sunshine

All of the different types of paired data:

- Storage-discharge
- Elevation-storage
- Elevation-area
- Elevation-discharge
- Inflow-diversion
- Diameter-percentage
- Cross sections
- Unit hydrograph curves
- Percentage curves
- Duration-precipitation
- ATI-meltrate
- ATI-coldrate
- Groundmelt patterns
- Percent patterns
- Cumulative probability

All of the different types of grid data:

- Precipitation
- Temperature
- Radiation
- Crop coefficient
- Storage capacity
- Percolation rate
- Storage coefficient
- Moisture deficit
- Impervious Area
- SCS curve number
- Elevation
- Cold content
- Cold content ATI
- Meltrate ATI
- Liquid water content
- Snow water equivalent
- Water content
- Water potential
- Air pressure
- Humidity
- Windspeed

Open a component manager to add shared data to a project. Go to the **Components** menu and select **Time-Series Data Manager**, **Paired Data Manager**, or **Grid Data Manager** command. Each one of these component managers contains a menu for selecting the type of data to create or manage. The **Paired Data Manager** with the **Storage-Discharge** data type selected is shown in Figure 7. Once the data type is selected, you can use the buttons on the right side of the component manager to add a New, Copy, Rename, and Delete a data type. There is also a button that opens an editor where you can change the description of the selected component. In the case of time-series data, the manager contains two extra buttons to add or delete time windows. A time window is needed for entering or viewing time-series data.

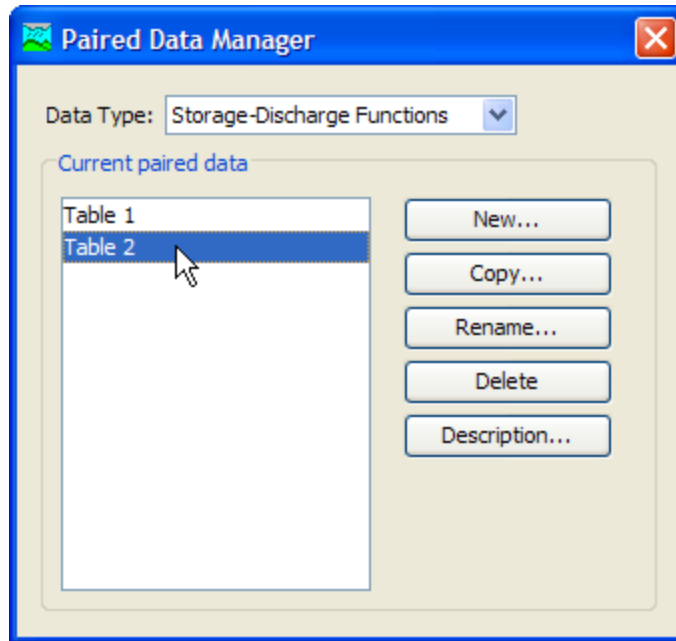

Figure 7. The paired data manager set to work with storage-discharge functions.







### ***Describe the Physical Watershed***

The physical watershed is represented in the basin model. Hydrologic elements are added and connected to one another to model the real-world flow of water in a natural watershed. A description of each hydrologic element is given in Table 9.

The basin model manager can be used to add a new basin model to the project. Open the basin model manager by selecting the **Components** ⇒ **Basin Model Manager** command. The basin model manager can be used to copy, rename, or delete an existing basin model.

Hydrologic elements can be added to the basin map after it is created. Select the basin model in the *Watershed Explorer* to open the basin map. If background map layers are available, add them to the basin model before adding elements. Add an element by selecting one of the tools from the toolbar, and clicking the left mouse button on the desired location in the basin map. Connect an element to a downstream element by right-clicking the upstream element to access the **Connect Downstream** menu item.

Table 9. Different kinds of hydrologic elements that can be used.

Hydrologic Element	Description
Subbasin 	The subbasin is used to represent the physical watershed. Given precipitation, outflow from the subbasin element is calculated by subtracting precipitation losses, calculating surface runoff, and adding baseflow.
Reach 	The reach is used to convey streamflow in the basin model. Inflow to the reach can come from one or many upstream elements. Outflow from the reach is calculated by accounting for translation and attenuation. Channel losses can optionally be included in the routing.
Junction 	The junction is used to combine streamflow from elements located upstream of the junction. Inflow to the junction can come from one or many upstream elements. Outflow is calculated by summing all inflows.
Source 	The source element is used to introduce flow into the basin model. The source element has no inflow. Outflow from the source element is defined by the user.
Sink 	The sink is used to represent the outlet of the physical watershed. Inflow to the sink can come from one or many upstream elements. There is no outflow from the sink.
Reservoir 	The reservoir is used to model the detention and attenuation of a hydrograph caused by a reservoir or detention pond. Inflow to the reservoir element can come from one or many upstream elements. Outflow from the reservoir can be calculated using one of three routing methods.
Diversion 	The diversion is used for modeling streamflow leaving the main channel. Inflow to the diversion can come from one or many upstream elements. Outflow from the diversion element consists of diverted flow and non-diverted flow. Diverted flow is calculated using input from the user. Both diverted and non-diverted flows can be connected to hydrologic elements downstream of the diversion element.

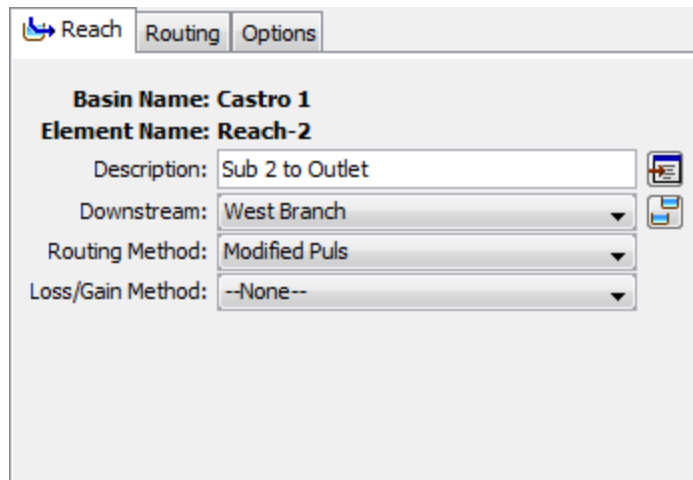

Figure 8. Reach component editor including data for routing and loss/gain methods. The downstream element is also shown.

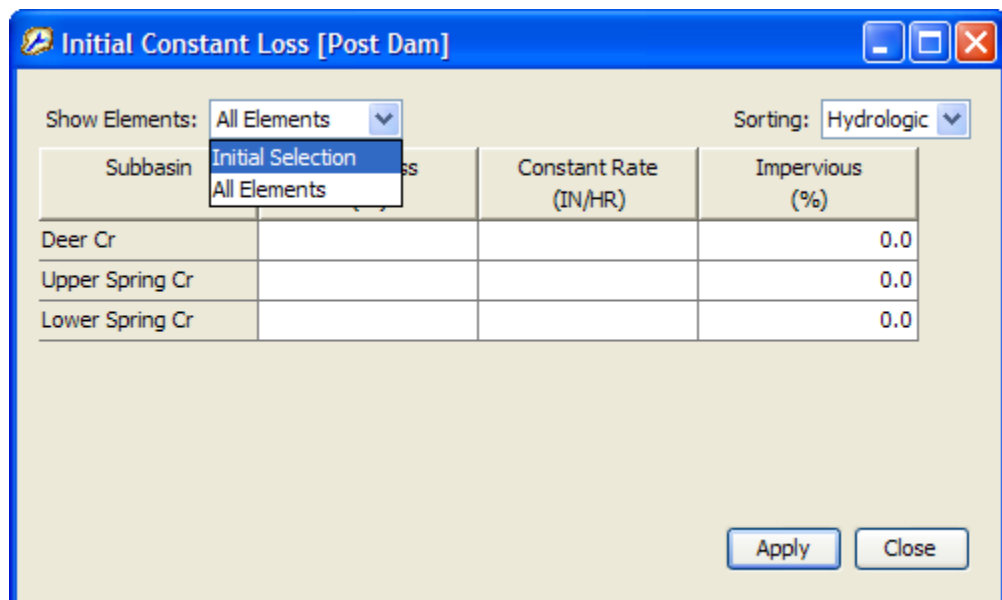

Figure 9. Global editor for the initial and constant loss method. Only the elements selected in the basin map are shown initially. You can switch between viewing the elements in the initial selection and viewing all elements in the basin model that use the selected method. You can also control how the elements are sorted.

Most hydrologic elements require parameter data so that the program can model the hydrologic processes represented by the element. In the case of the subbasin element, many mathematical models are available for determining precipitation losses, transforming excess precipitation to streamflow at the subbasin outlet, and adding baseflow. In this document the different mathematical models will be referred to as methods. The available methods for subbasin and reach elements are shown in Table 10. Parameter data is entered in the *Component Editor*. Select a hydrologic element in the basin map or *Watershed*

*Explorer* to open the correct *Component Editor* as shown in Figure 8. Global parameter editors can also be used to enter or view parameter data for many hydrologic elements as shown in Figure 9. Global parameter editors are opened using the **Parameters** menu.

*Table 10. Methods available in the subbasin and reach hydrologic elements.*

Hydrologic Element	Calculation Type	Method
Subbasin	Canopy	Dynamic
		Simple (also gridded)
	Surface	Simple (also gridded)
	Loss Rate	Deficit and constant (also gridded)
		Exponential
		Green and Ampt (also gridded)
		Initial and constant
		SCS curve number (also gridded)
		Smith Parlange
		Soil moisture accounting (also gridded)
Transform		Clark unit hydrograph
Kinematic wave		
ModClark		
SCS unit hydrograph		
Snyder unit hydrograph		
User-specified s-graph		
User-specified unit hydrograph		
Baseflow	Bounded recession	
	Constant monthly	
	Linear reservoir	
	Nonlinear Boussinesq	
	Recession	
Reach	Routing	Kinematic wave
		Lag
		Modified Puls
		Muskingum
		Muskingum-Cunge
		Straddle stagger
		Gain/Loss
	Percolation	



## **Describe the Meteorology**

The meteorologic model calculates the precipitation input required by a subbasin element. The meteorologic model can utilize both point and gridded precipitation and has the capability to model frozen and liquid precipitation along with evapo-transpiration. The snowmelt methods model the accumulation and melt of the snow pack. The evapo-transpiration methods include the constant monthly, Priestley Taylor, and Penman Monteith methods, with gridded options available. An evapo-transpiration method is only required when simulating the continuous or long term hydrologic response in a watershed. When an energy balance evapo-transpiration or snowmelt method is selected, the shortwave and longwave radiation must also be specified. A brief description of the methods available for calculating basin average precipitation or grid cell precipitation is included in Table 11.

Use the meteorologic model manager to add a new meteorologic model to the project. Go to the Components menu and select the correct option from the menu list. The meteorologic model manager can also be used to copy, rename, and delete an existing meteorologic model.

*Table 11. Precipitation methods available for describing meteorology.*

<b>Precipitation Methods</b>	<b>Description</b>
Frequency storm	Used to develop a precipitation event where depths for various durations within the storm have a consistent exceedance probability.
Gage weights	User specified weights applied to precipitation gages.
Gridded precipitation	Allows the use of gridded precipitation products, such as NEXRAD radar.
Inverse distance	Calculates subbasin average precipitation by applying an inverse distance squared weighting with gages.
HMR52	Probable maximum precipitation (PMP) using the HMR52 procedure.
SCS storm	Applies a user specified SCS time distribution to a 24-hour total storm depth.
Specified hyetograph	Applies a user defined hyetograph to a specified subbasin element.
Standard project storm	Uses a time distribution to an index precipitation depth.

## Enter Simulation Time Windows

A simulation time window sets the time span and time interval of a simulation run. A simulation time window is created by adding a control specifications to the project. This can be done using the control specifications manager. Go to the **Components** menu and select the correct option from the menu list. Besides creating a new simulation time window, the control specifications manager can be used to copy, rename, and delete an existing window.

Once a new control specifications has been added to the project, use the mouse pointer and select it in the *Watershed Explorer*. This will open the *Component Editor* for the control specifications as shown in Figure 10. Information that must be defined includes a starting date and time, ending date and time, and time interval. The grid data output interval and grid time shift are specific to simulations that included gridset data.

Control Specifications	
<b>Name:</b>	Jan73
Description:	Storm of 16 January 1973
*Start Date (ddMMYYYY)	16Jan1973
*Start Time (HH:mm)	03:00
*End Date (ddMMYYYY)	16Jan1973
*End Time (HH:mm)	12:55
Time Interval:	5 Minutes
Grid Interval:	5 Minutes
Grid Time Shift (HR)	0

Figure 10. Control specifications component editor. The starting date and time are required, along with the ending date and time.

## Simulate and View Results

A simulation run calculates the precipitation-runoff response in the basin model given input from the meteorologic model. The control specifications define the time period and time interval. All three components are required for a simulation run to compute.

Create a new simulation run by selecting the **Compute ⇒ Create Simulation Run** menu option. A wizard will open to step you through the process of creating a simulation run as shown in Figure 11. First, enter a name for the simulation. Then, choose a basin model, meteorologic model, and control specifications. After the simulation run has been created, select the run. Go to the **Compute ⇒ Select Run** menu option. When the mouse moves on top of **Select Run** a list of

available runs will open. Choose the correct simulation. To compute the simulation, reselect the **Compute** menu and choose the **Compute Run** option at the bottom of the menu.

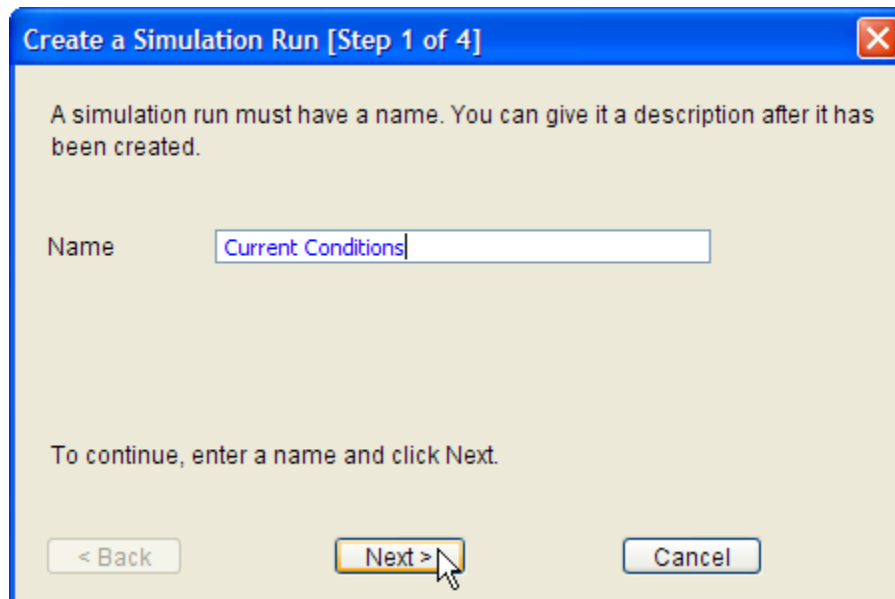

Figure 11. Using the wizard to create a new simulation run.

Results can be accessed from the basin map and the *Watershed Explorer*, "Results" tab. Results are available as long as a simulation run has been successfully computed and no edits have been made after the compute to any component used by the simulation run. For example, if the time of concentration parameter was changed for a subbasin element after the simulation run was computed, then results are no longer available for that hydrologic element and any elements downstream of it in the basin model. The simulation run must be recomputed for results to become available.

The simulation must be selected (from the **Compute** menu or *Watershed Explorer*) before results can be accessed from the basin map. After the simulation run is selected, select the hydrologic element where you want to view results. While the mouse is located on top of the element icon, click the right mouse button. In the menu that opens, select the **View Results** option. Three result types are available: **Graph**, **Summary Table**, and **Time-Series Table** (Figure 12). These results can also be accessed through the toolbar and the **Results** menu. A hydrologic element must be selected before the toolbar buttons and options from the Results menu are active. A global summary table is available from the toolbar and **Results** menu. The global summary table contains peak flows and time of peak flows for each hydrologic element in the basin model.

Results can also be viewed from the *Watershed Explorer*, "Results" tab. Select the simulation run and the *Watershed Explorer* will expand to show all hydrologic elements in the basin model. If you select one of the hydrologic elements, the *Watershed Explorer* expands again to show all result types as shown in Figure 13. For a subbasin element, you might see outflow, incremental precipitation, excess precipitation, precipitation losses, direct runoff, and baseflow as the output results. Select one of these results to open a preview graph. Multiple results can be selected and viewed by holding down the Control or Shift buttons. Results from multiple hydrologic elements can be viewed together. Also, results from different simulation runs can be selected and viewed. Once output types are selected in the *Watershed Explorer*, a larger graph or time-series table can be opened in the *Desktop* by selecting the **Graph** and **Time-Series** buttons on the toolbar.

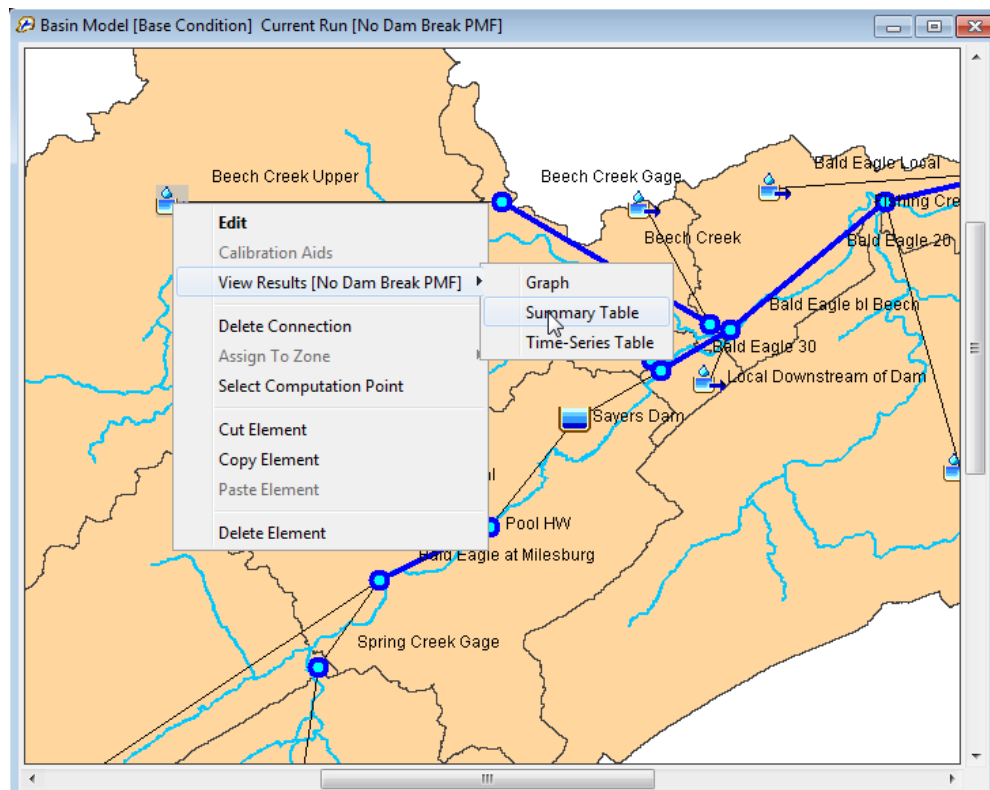

Figure 12. Accessing results for the current simulation run using the basin map.

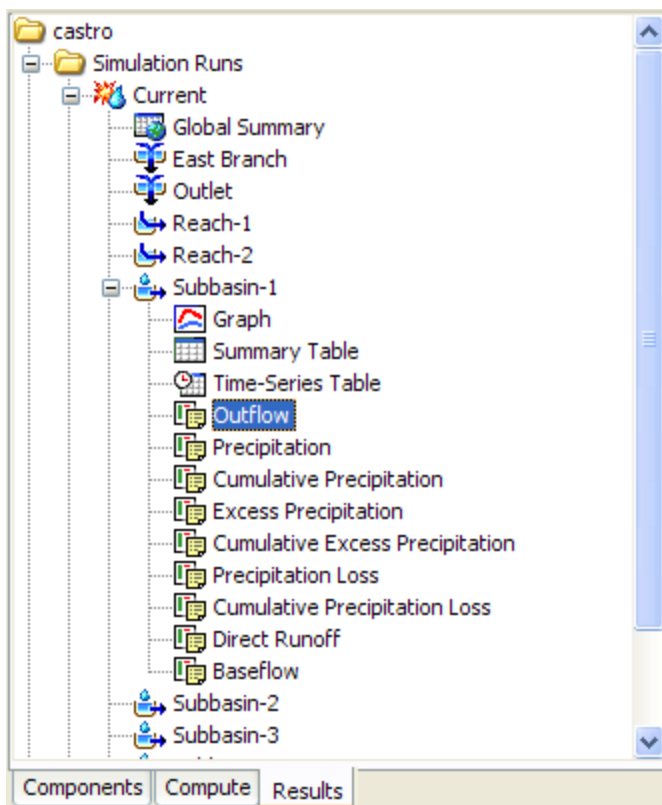

Figure 13. Selecting simulation run results from the Watershed Explorer.

### Create or Modify Data

Many hydrologic studies are carried out to estimate the change in runoff given some change in the watershed. For example, a residential area is planned in a watershed. The change in flow at some point downstream of the new residential area is required to determine if flooding will occur as a result of the new residential area. If this is the case, then two basin models can be developed. One is developed to model the current rainfall-runoff response given predevelopment conditions and another is developed to reflect future development.

An existing basin model can be copied using the basin model manager or the right mouse menu in the *Watershed Explorer*. In the *Watershed Explorer*, "Components" tab, select the basin model. Keep the mouse over the selected basin model and click the right mouse button. Select the **Create Copy...** menu item to copy the selected basin model. The copied basin model can be used to model the future development in the watershed.

To reflect future changes in the watershed, method parameters can be changed. For example, the percent impervious area can be increased for a subbasin element to reflect the increase in impervious area from

development. Routing parameters can also be adjusted to reflect changes to the routing reach.

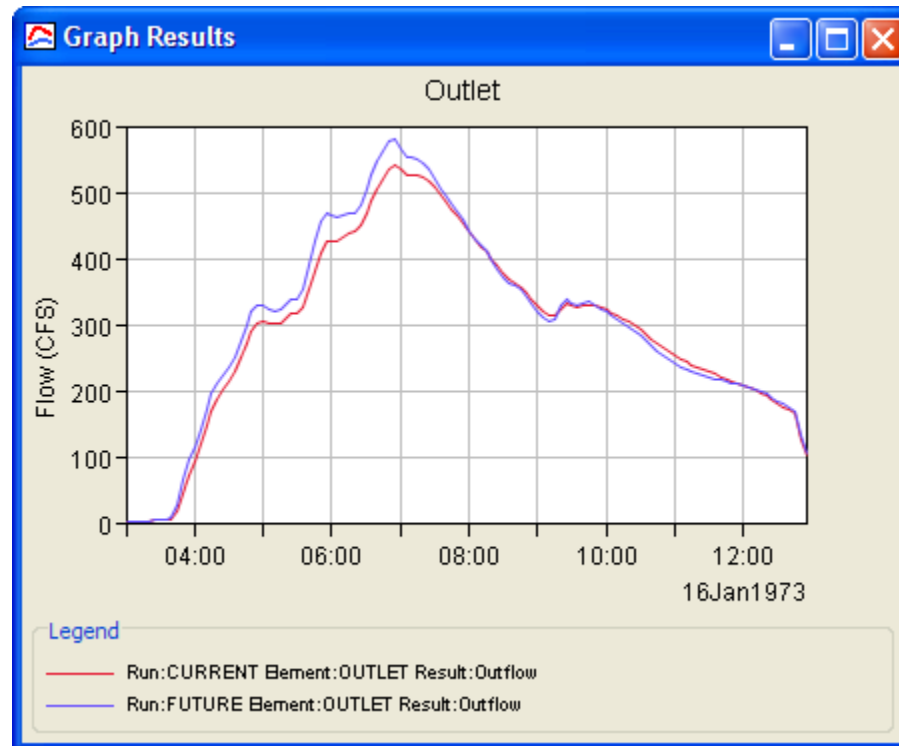

Figure 14. Graph comparing outflow in the same element in two different simulation runs. The correct time-series were selected in the *Watershed Explorer* and then the graph toolbar button was pressed.

### **Make Additional Simulations and Compare Results**

Additional simulations can be created using new or modified model components. Results from each simulation run can be compared to one another in the same graph or time-series table. Select the "Results" tab in the *Watershed Explorer*. Select each simulation run that contains results you want to compare. The *Watershed Explorer* will expand to show all hydrologic elements in the basin models. Select the hydrologic element in all simulation runs where results are needed. This will expand the *Watershed Explorer* even more to show available result types. Press the Control key and select each output result from the different simulation runs. When a result type is selected the result is added to the preview graph. Once all the results have been selected, a larger graph or time-series table can be opened by selecting the **Graph** and **Time-Series** buttons on the toolbar as seen in Figure 14.

### ***Exit the Program***

Save the project by selecting the **File** ⇒ **Save** menu item. After the project is saved, exit the program by selecting the **File** ⇒ **Exit** menu item.

### ***References***

Taylor, B. 1995. Special Publication 811: Guide for the Use of the International System of Units (SI). United States Department of Commerce, National Institute of Standards and Technology. Gaithersburg, MD.

This Page Left Blank



## CHAPTER 4

# ***Projects and Control Specifications***

A project serves as a container for all the different parts that together form the complete representation of a watershed. Control specifications are one of the main components of a project, and are principally used to control simulation runs. The remainder of the project components are described in later chapters. This chapter describes how to create and manage projects. It also includes information on how the file system is used by the program to organize and access the files that represent the project components. Finally, it describes the control specifications.

### ***Projects***

A project represents all of the input data and simulation output necessary to answer an engineering question. Possible questions could include the following:

- What will be the flow rate at the bridge due to a 1% storm?
- How will the average in-stream flow depth for the month of July change after the operation schedule of an irrigation diversion is modified?
- What is the impact of changing the land use on 7% of the watershed from cow pasture to home sites?
- How will the frequency curve be affected by building a reservoir?

The questions may involve a single watershed or several adjacent watersheds. There may only be a single representation of the watershed, or multiple representations may be needed for different future scenarios. The project is flexible enough to work with any of these applications.

### ***Creating a New Project***

Select the **File** ⇒ **New...** menu command to create a new project. After this command is selected, the *Create a New Project* window will open where you can name, select the location on your computer or network server to store the project, and describe the project with a description (Figure 15). If the project description is long you can use

the button to the right of the description field to open an editor. A default location is provided. The default location for creating new projects is specified in the program settings described in [Chapter 3](#). You are not required to use the default directory and may create a new project on the local computer or a network resource anywhere your security limitations permit. All project files created by the program will be saved in a folder (the folder name is the name of the project) in the location entered. Select the default unit system for creating new components. The unit system of a component can always be changed after it is created. Press the **Create** button when you are satisfied with the name, location, and description. You cannot press the **Create** button if no name or location is specified. If you change your mind and do not want to create a new project, press the **Cancel** button or the **X** button in the upper right to close the window. The *Create a New Project* window can also be opened by pressing the **Create a New Project** button on the toolbar.

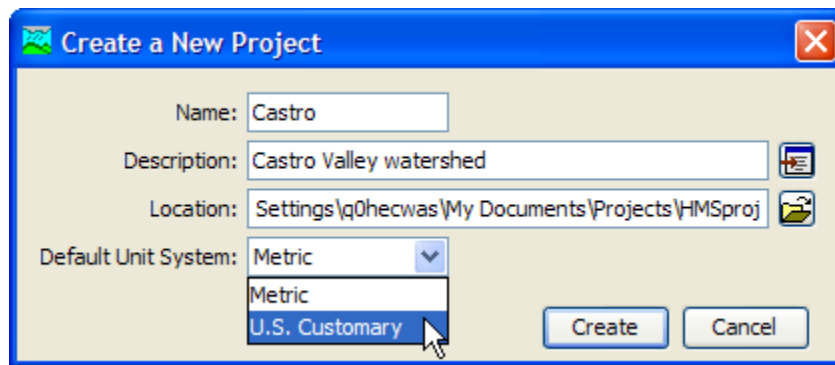

Figure 15. *Creating a new project. The location may be changed to suit your preferences for storing and organizing projects.*

## Opening a Project

Open a project by selecting the **File** ⇒ **Open...** menu option. After this option is selected, the *Open an Existing Project* window will open as shown in Figure 16. This window contains all projects in the watershed list. The watershed list contains all projects previously opened by the program. Open a project by clicking the project name and pressing the **Open** button. You may also double-click a project name to open it. You cannot press the **Open** button if no project is selected. If the project you want to open is not in the list, press the **Browse** button. The *Select Project File* window opens that lets you navigate to the directory containing the desired project (Figure 17). If you change your mind and do not want to open a project, press the **Cancel** button or the **X** button in the upper right to close the window. The *Open an Existing Project* window can also be opened by pressing the **Open a Project** button on the toolbar.

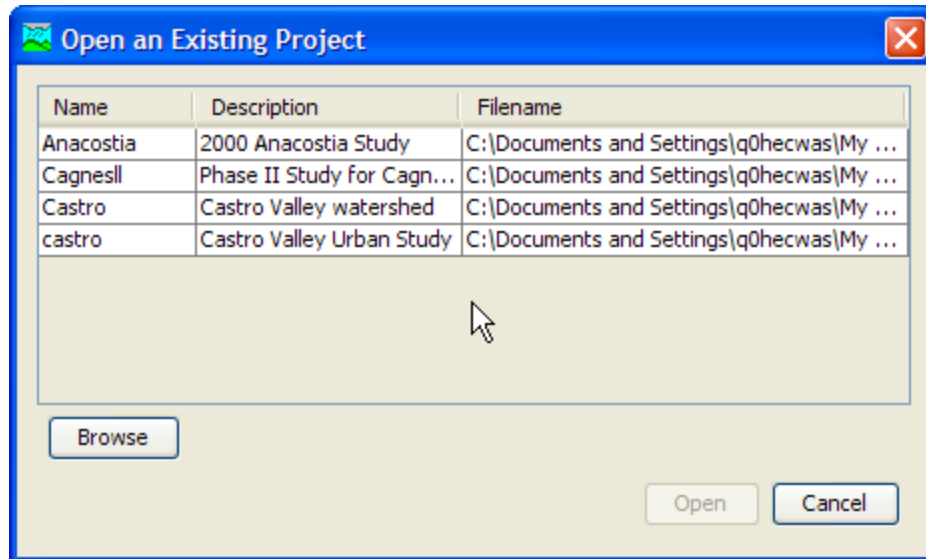

Figure 16. Opening a project. Previously opened projects are kept on a list for easy reference.

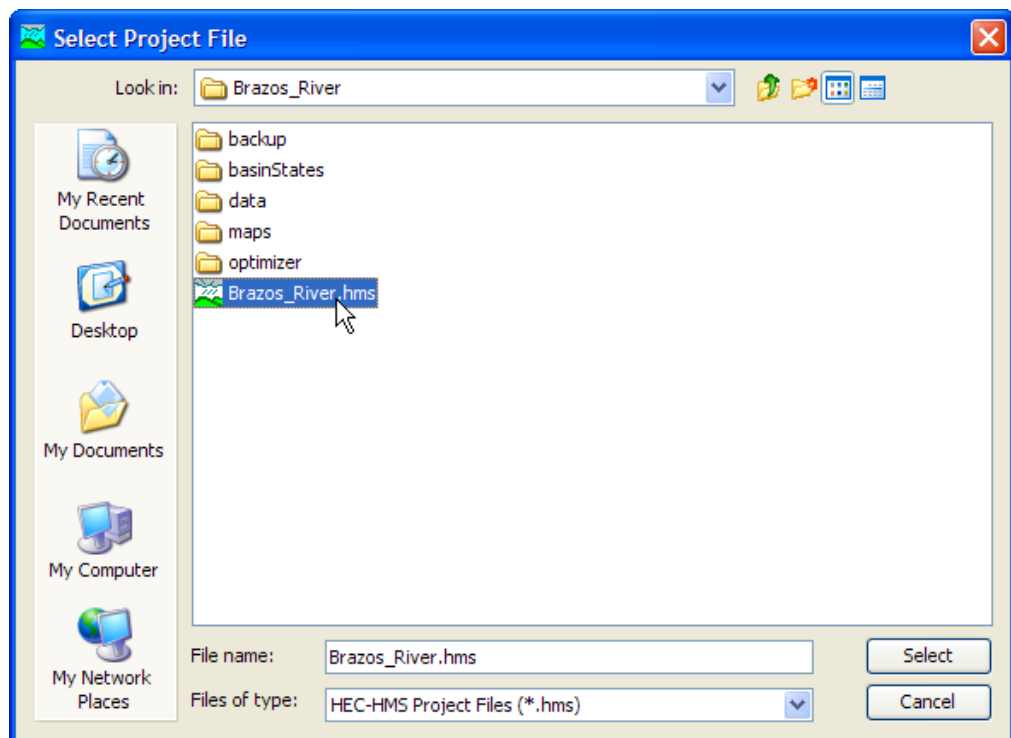

Figure 17. Browsing to open a project that has not been opened previously. Select the project file with extension HMS to open that project.

### Copying a Project

Copy a project by selecting the **File** ⇒ **Save As...** menu option. After this option is selected, the *Save Current Project As* window will open where you can name, select the location on your computer or network server to store the project, and describe the project as shown in Figure

18. A default location is provided. The default location for creating new projects is specified in the program settings described in [Chapter 3](#).

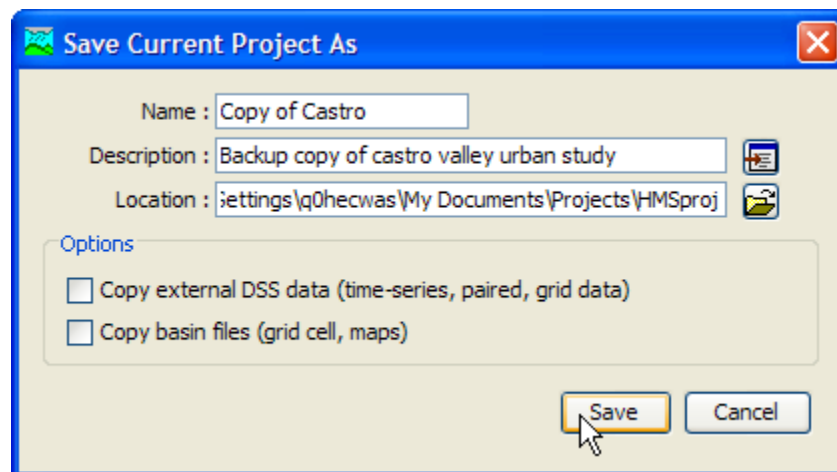

Figure 18. Saving a copy of the current project.

You are not required to use the default directory and may copy a project to the local computer or a network resource anywhere your security limitations permit. All project files will be copied to a folder (the folder name is the name of the project) in the location entered. If the project description is long you can use the button to the right of the description field to open an editor. Press the **Copy** button when you are satisfied with the name, location, and description. You cannot press the **Copy** button if no name or location is specified. If you change your mind and do not want to create a copy, press the **Cancel** button or the **X** button in the upper right to close the window.

There are two options in this window that need extra attention. The first option, **Copy external DSS data (time-series, paired, grid data)**, will copy all external DSS records defined in the project and place the copied records into DSS files in the new project folder. Time-series, paired, and grid data are copied into separate DSS files. All references to these DSS records are automatically updated. The second option, **Copy basin files (grid cell, maps)**, will copy all grid cell files and background map layer files used by all basin models in the project and paste them into the new project folder. The background map layer files are placed in a folder named "Maps." All references to grid cell and map layer files are automatically updated.

### ***Renaming a Project***

Rename a project by selecting the **File** ⇒ **Rename** menu option. After this option is selected, the *Rename Current Project* window opens (Figure 19). The window shows the current project name and description and contains a text box for you to enter the new project

name and description. If the project description is long you can use the button to the right of the description field to open an editor. Press the **Rename** button when you are satisfied with the name and description. You cannot press the **Rename** button if no name is specified. If you change your mind and do not want to rename the project, press the **Cancel** button or the **X** button in the upper right to close the window.

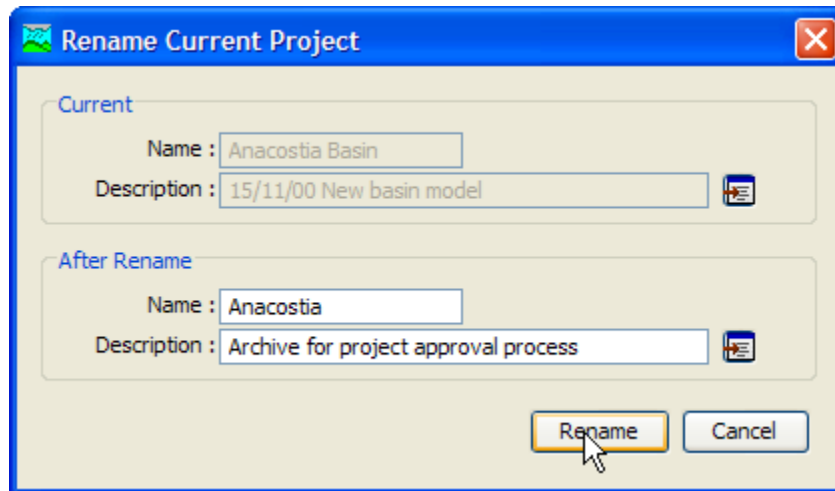

Figure 19. Renaming the current project.

### **Deleting a Project**

Delete a project by selecting the **File** ⇒ **Delete** menu item. The *Delete Current Project* window will open (Figure 20). This window contains the project name and description and three choices for deleting the project. The first option, **Watershed entry in watershed list only (all files remain intact)**, will only delete the project from the watershed list. The watershed list contains all projects previously opened by the program. No files are deleted when this option is selected. The second option, **Watershed entry and all watershed files (external files remain intact)**, will delete the project from the project list and delete all project files. Project files include \*.hms, \*.basin, etc. (refer to Table 12 for a complete list of project files). No external files are deleted when this option is selected. External files include DSS, grid cell, and background map layer files. The third option, **Watershed entry, watershed files, and all external files**, will delete the project from the watershed list, all files created by the program for this project, and all external files referenced by the project (DSS, grid cell, and background map layer files). It is very important to keep in mind that the third option will delete external files which could be used by other projects. After the appropriate option is selected, press the **Delete** button. Once a project has been deleted it cannot be retrieved or undeleted. If you change your mind and do not want to delete the

project, press the **Cancel** button or the **X** button in the upper right to close the window.

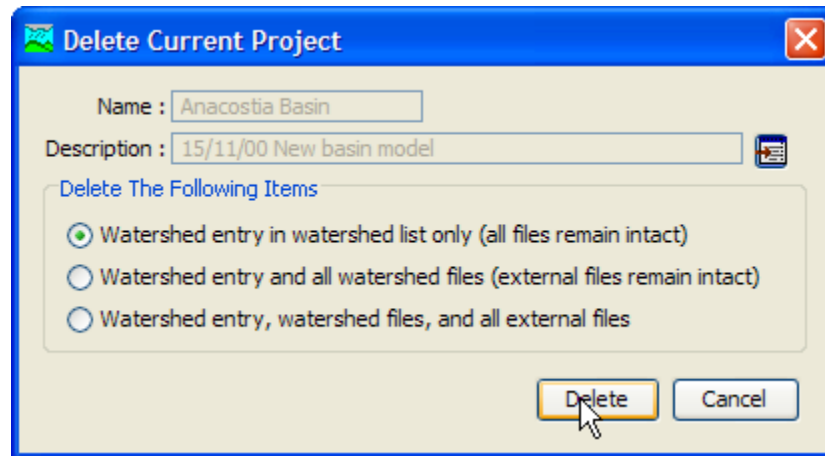

Figure 20. Preparing to delete the current project.

## Project Properties

Basic properties and settings for the project are provided in the *Component Editor* for the project. Access the *Component Editor* on any tab of the *Watershed Explorer*. The highest level folder is labeled with the project name; click on the project name to display the *Component Editor* (Figure 21).

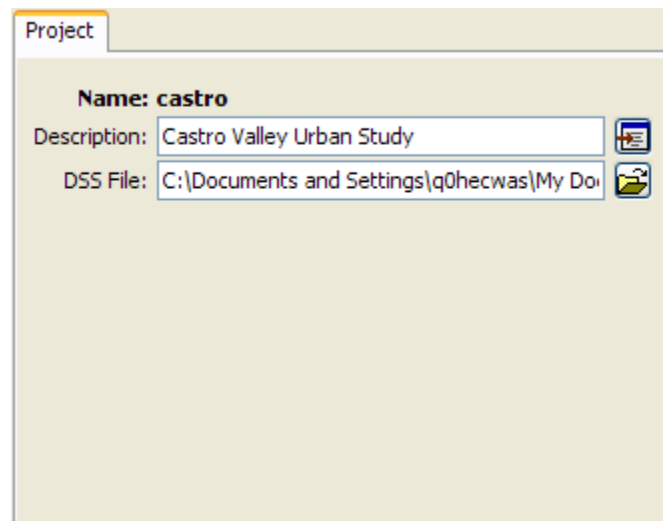

Figure 21. Project component editor accessed by clicking on the top node of the *Watershed Explorer*. The top node is labeled with the project name.

The description can be used to provide internal documentation. It is helpful to include notes and comments within the project to remind yourself of details at a later time. It also helps with providing information to other users who may work with the project in the future.

If the description is short, you can type it directly into the description field. For long descriptions, you can press the editor button to the right of the description field. The description editor makes it easier to enter and edit long descriptions.

Output results are written to the project DSS file by default. However, you can change the file where results are written. Results will not be available after changing the output DSS file until the component is recomputed. If you wish, you can press the folder button to the right of the file field to open a file browser for locating the file. The file browser is set to locate files with the DSS extension. If you change your mind about searching for a different output file, you can press the **Cancel** button or the **X** button in the upper right of the browser window. Press the **Select** button after you locate and highlight the desired file. It is possible to have more than one project write output results to the same DSS file. However, the separate projects are not synchronized and extreme care must be taken in naming components in order to avoid conflicts.

## ***Directories and Files***

The program automatically creates and manages many different files, all of which are stored in the project directory. A project directory is automatically created in the file system when a new project is created. Even though multiple projects can be stored in the same directory, it is recommended that each project be stored in a separate directory. Separate directories improve file system organization and facilitate archiving by external backup software.

### ***Files Generated by the Program***

Each data set or class of data sets is stored in a separate file in the project directory. The names used for components or data sets are automatically converted to filenames for the files. Underscores are substituted for special characters not allowed by the operating system. For example, a basin model named North Branch would be stored in the file `North_Branch.basin`. A complete list of files used by the program is shown in Table 12. A majority of the files are in ASCII format but the user should never need to look at the files. Management should always be performed using program commands in the graphical user interface since some information is stored in multiple files. The program may not operate correctly when files are unsynchronized because of external management operations.

*Table 12. Files created by the program for storing component data. Sample names have been used assuming a project named Castro, that contains a basin model named North Branch, a meteorologic model named Historic Calib, and a control specifications named Oct 1977. It is also assumed that all features of the program are used including an optimization trial named Est Baseflow, and a saved state named Mid Oct 77.*

<b>Filename</b>	<b>Description</b>
Castro.access	Control file; contains no data.
Castro.dsc	Catalog of the project DSS file to speed finding specific records.
Castro.dss	Project DSS file containing manual entry time-series gages and paired data. Default file for output results.
Castro.gage	List of all time-series gages.
Castro.grid	List of all grid data.
Castro.hms	Project definition including lists of basin models, meteorologic models, and control specifications.
Castro.log	All messages are recorded in the log file except for messages generated during a compute. Each compute component has its own log file.
Castro.nals	List of all depth-area analyses.
Castro.out	List of all data read or written from DSS files.
Castro.pdata	Listing of all paired data.
Castro.run	List of simulation runs with their properties and the time of last compute.
North_Branch.basin	Configuration for element properties, channel network, zones, and map layers. One per basin.
Historic_Calib.met	Configuration for precipitation, evapotranspiration, and snowmelt data. One per meteorologic model.
Oct_1977.control	Configuration for start time, end time, and time interval. One per control specifications.
Castro.trial	List of all the optimization trials.
Est_Baseflow.optim	Optimization trial properties including search method, objective function, and parameters.
Castro.fcstList	list of all forecast alternatives.
DryStart.forecast	Forecast alternatives properties including start and end times, blending controls, and parameter adjustments. One per forecast alternative
Castro.stateIndex	List of all the saved states.
Mid_Oct_77.state	Saved state information for all the hydrologic elements in a specific basin model.



### ***Files Specified by the User***

Files that are not automatically created and managed by the program can be added to the project directory by the user. Optional background map files can be added and used in basin models. The grid cell file required by the ModClark gridded transform method must be created external to the program. These optional and required files can be stored at any location on the computer file system, but it is often convenient to store them in the project directory. Additional supplementary files, related to the project but not used by the program, can also be placed in the project directory and will be ignored. However, when a project is copied, only files used by the program will be copied.

### ***Manually Entered Time-Series and Paired Data***

The project DSS file stores all time-series and paired data that is manually entered by the user. The data entered by the user is automatically stored as a record in the file. When the data is edited the record is automatically updated. The record is automatically updated if the time-series gage or paired data function is renamed, copied, or deleted. The record can be accessed by other programs that can read and write in the DSS format.

Each DSS record contains only one type of data. Information about the data is stored in a header inside the record. The header for time-series data includes the record name, whether the data is on a regular or irregular time interval, start date and time, end date and time, number of values, measurement units, and data type. The header for paired data includes the record name, number of curves, measurement units of the first series, data type of the first series, measurement units of the second and subsequent series, and data type of the second and subsequent series.

### ***Computed Results***

By default, all computed results are stored in the project DSS file. However, the user has the option of changing the file where computed results are stored. Any manually entered time-series or paired data will continue to be stored in the project DSS file regardless of the file used for computed results. If the computed results are stored in a different file, that file can be safely deleted without affecting the program. However, it is not possible to view results after deleting the file where they are stored.

The result from each element is stored in a separate record. Some elements compute different types of results; each result is stored in a separate record. The record is identified with a pathname. Each

record pathname contains six parts called the A-part, B-part, C-part, D-part, E-part, and F-part. The pathname parts are separated with a slash and may contain spaces. The complete pathname, including slashes and spaces, can total up to 256 uppercase characters. The following is an example of a pathname for the computed flow at a hydrologic element named "Sand Cr" in simulation run "Plan 3A":

```
//SAND CR/FLOW/01JAN1985/1HOUR/RUN:PLAN 3A/
```

A consistent naming convention is used for assigning the different pathname parts of the computation results (HEC, 1994). The B-part is assigned the name of the element in the basin model. The C-part is assigned a data descriptor as described in Appendix A. The D-part is assigned the simulation start date. The E-part is assigned the simulation time interval. The F-part begins with a three-letter code that identifies the type of computed result, followed by a colon and the name of the compute component.

### ***External Time-Series, Paired, and Grid Data***

Any time-series or paired data that is not manually entered must be stored in an external DSS file. Grid data cannot be manually entered and so must be stored in an external DSS file. External DSS files are all DSS files used in a project except the project DSS file which was created to store model data and computation results. The external files can store regular or irregular interval time-series data, paired data, or grid data. They can be located anywhere on the computer or network and shared with other programs. This program automatically determines the data type, units, and interval from the record header.

### ***Security Limitations***

The program can create a project on the local computer or on any accessible network device. Creating a project requires the user to have read and write permission for the folder that will contain the new project. Usually the system administrator determines where a user has permission to read and write. Depending on the security settings assigned to the user by the system administrator, the program may not be able to create a project in some folders. As a user, be sure you understand where you have permission to create new projects. No other privileges beyond read and write permission are required to use the program; it is fully compatible with operating in a so-called reduced privilege environment.

The program automatically checks all of the project files for read and write permission every time the project is opened. If any of the files are read-only, then the program will not be able to open the project and an error message will be displayed. If a project was previously

accessible but becomes inaccessible, it is possible that the file permissions were changed external to the program. It is also possible for the files to have read-only permission if they are copied from a CD-ROM or other removable storage media. If the files have been set to read-only permission for any reason, you will need to manually change the permissions on the files before the program can open the project. If you are using the Microsoft Windows® operating system, you can change file permissions using Windows Explorer. On the Linux® operating systems, you can open a command window and use the `chmod` command.

The program is designed to work with projects that may be shared by several users. Usually shared projects will be stored on a server or network storage device, but could be stored in a shared folder on a local computer. All users who will share the project must have read and write permission for that folder. Even though several users may share the project, only one user can access the project at a time. The program automatically tracks how many users are accessing a project and limits access as necessary.

## ***Control Specifications***

Control specifications are one of the main components in a project, even though they do not contain much parameter data. Their principle purpose is to control when simulations start and stop, and what time interval is used in the simulation.

### ***Creating a New Control Specifications***

A new control specifications is created using the *Control Specifications Manager*. To access the manager, click on the **Components** menu and select the **Control Specifications Manager** command. The manager will open and show all of the control specifications currently in the project. The manager can remain open while you manage control specifications or while you perform tasks elsewhere in the program. You can close the manager using the **X** button in the upper right corner. The buttons to the right of the specifications list can be used to manage existing specifications or create a new one. To create a new control specifications, press the **New...** button. After you press the button a window (Figure 22) will open where you can name and describe the new control specifications that will be created. A default name is provided for the new specifications; you can use the default or replace it with your own choice. A description can also be entered. If the description is long, you can press the button to the right of the description field to open an editor. The editor makes it easy to enter and edit long descriptions. When you are satisfied with the name and description, press the **Create** button to finish the process of creating

the new control specifications. You cannot press the **Create** button if no name is specified for the new specifications. If you change your mind and do not want to create a new control specifications, press the **Cancel** button or the **X** button in the upper right to return to the *Control Specifications Manager* window.

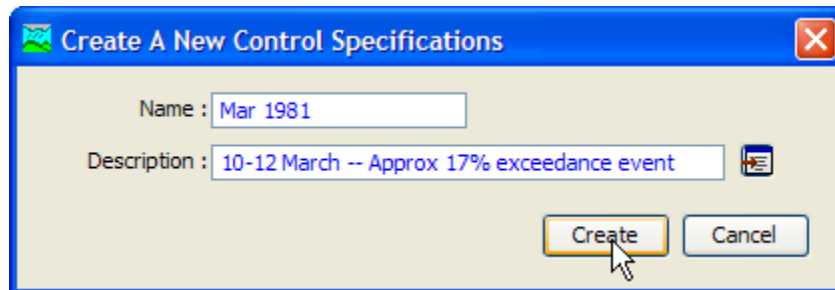

Figure 22. Creating a new control specifications. This was accessed by opening the *Control Specifications Manager* from the *Components* menu, and then pressing the *New...* button.

### **Copying a Control Specifications**

There are two ways to copy a control specifications. Both methods for copying a specifications create an exact duplicate with a different name. Once the copy has been made it is independent of the original and they do not interact.

The first way to create a copy is to use the *Control Specifications Manager*, which is accessed from the **Components** menu. Select the control specifications you wish to copy by clicking on it in the list of current control specifications. The selected specifications is highlighted after you select it. After you select a specifications you can press the **Copy...** button on the right side of the window. A new *Copy Control Specifications* window (Figure 23) will open where you can name and describe the copy that will be created. A default name is provided for the copy; you can use the default or replace it with your own choice. A description can also be entered; if it is long you can use the button to the right of the description field to open an editor. When you are satisfied with the name and description, press the **Copy** button to finish the process of copying the selected control specifications. You cannot press the **Copy** button if no name is specified. If you change your mind and do not want to copy the selected control specifications, press the **Cancel** button or the **X** button in the upper right to return to the *Control Specifications Manager* window.

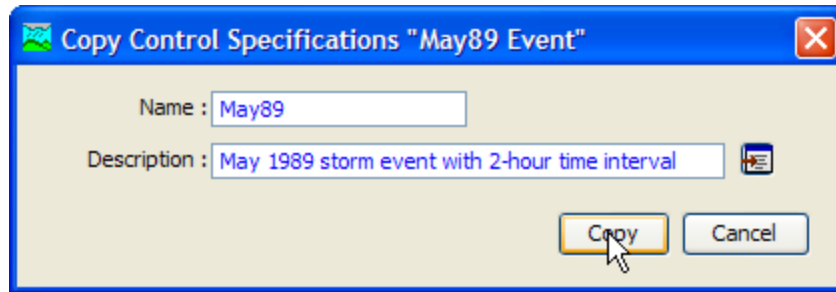

Figure 23. Creating a copy of a control specifications.

The second way to copy is from the "Components" tab of the *Watershed Explorer*. Move the mouse over the control specifications you wish to copy, then press the right mouse button (Figure 24). A context menu is displayed that contains several choices including copy. Click the **Create Copy...** command. A new *Copy Control Specifications* window will open where you can name and describe the copy that will be created. A default name is provided for the copy; you can use the default or replace it with your own choice. A description can also be entered; if it is long you can use the button to the right of the description field to open an editor. When you are satisfied with the name and description, press the **Copy** button to finish the process of copying the selected control specifications. You cannot press the **Copy** button if no name is specified. If you change your mind and do not want to copy the selected control specifications, press the **Cancel** button or the **X** button in the upper right of the *Copy Control Specifications* window to return to the *Watershed Explorer*.

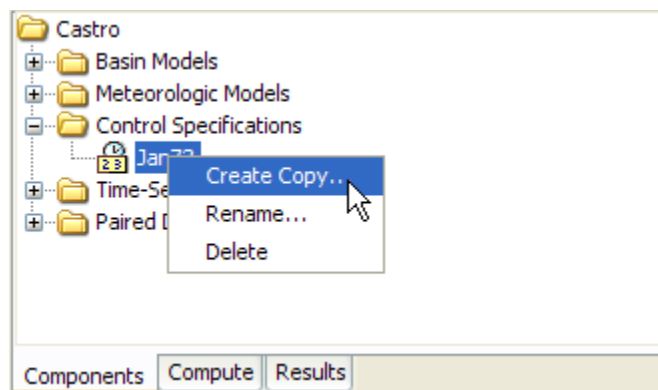

Figure 24. Copying a control specifications from the *Watershed Explorer*. The *Copy Control Specifications* window will appear after the **Create Copy...** menu command is selected.

### **Renaming a Control Specifications**

There are two ways to rename a control specifications. Both methods for renaming a specifications change its name and then all references to the old specifications name are automatically updated to the new name.

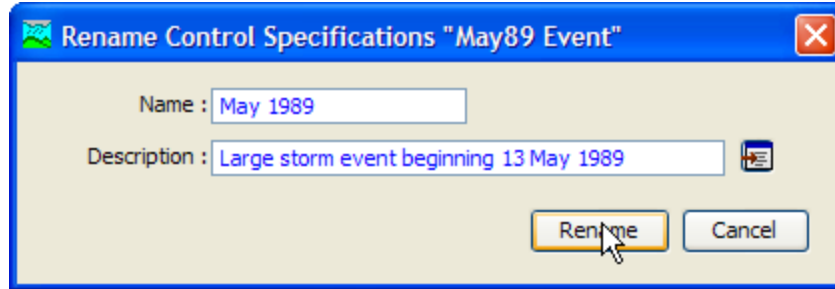

Figure 25. Renaming a control specifications. This was accessed from the Control Specifications Manager.

The first way to perform a rename is to use the *Control Specifications Manager*, which you can access from the **Components** menu. Select the control specifications you wish to rename by clicking on it in the list of current control specifications. The selected specifications is highlighted after you select it. After you select a specifications you can press the **Rename...** button on the right side of the window. A new *Rename Control Specifications* window (Figure 25) will open where you can provide the new name. If you wish you can also change the description at the same time. If the new description will be long, you can use the button to the right of the description field to open an editor. When you are satisfied with the name and description, press the **Rename** button to finish the process of renaming the selected control specifications. You cannot press the **Rename** button if no name is specified. If you change your mind and do not want to rename the selected control specifications, press the **Cancel** button or the **X** button in the upper right of the *Rename Control Specifications* window to return to the *Control Specifications Manager* window.

The second way to rename is from the "Components" tab of the *Watershed Explorer*. Select the control specifications you wish to rename by clicking on it in the *Watershed Explorer*; it will become highlighted. Keep the mouse over the selected specifications and click the right mouse button. Select the **Rename...** command from the menu and the highlighted name will change to editing mode as shown in Figure 26. You can then move the cursor with the arrow keys on the keyboard or by clicking with the mouse. You can also use the mouse to select some or all of the name. Change the name by typing with the keyboard. When you have finished changing the name, press the **Enter** key to finalize your choice. You can also finalize your choice by clicking elsewhere on the "Components" tab. If you change your mind while in editing mode and do not want to rename the selected control specifications, press the **Escape** key.

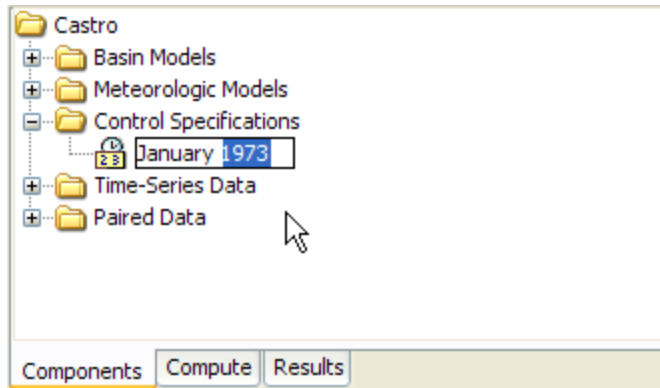

Figure 26. Renaming a control specifications in the Watershed Explorer.

### Deleting a Control Specifications

There are two ways to delete a control specifications. Both methods for deleting a specifications remove it from the project and then automatically update all references to that specifications. Once a specifications has been deleted it cannot be retrieved or undeleted. Any references to the deleted specifications will switch to using no control specifications, which is usually not a valid choice during a simulation. At a later time you will have to go to those components and manually select a different control specifications.

The first way to perform a deletion is to use the *Control Specifications Manager*, which you can access from the **Components** menu. Select the control specifications you wish to delete by clicking on it in the list of current control specifications. The selected specifications is highlighted after you select it. After you select a specifications you can press the **Delete** button on the right side of the window. A window will open where you must confirm that you wish to delete the selected specifications as shown in Figure 27. Press the **OK** button to delete the specifications. If you change your mind and do not want to delete the selected control specifications, press the **Cancel** button or the **X** button in the upper right to return to the *Control Specifications Manager* window.

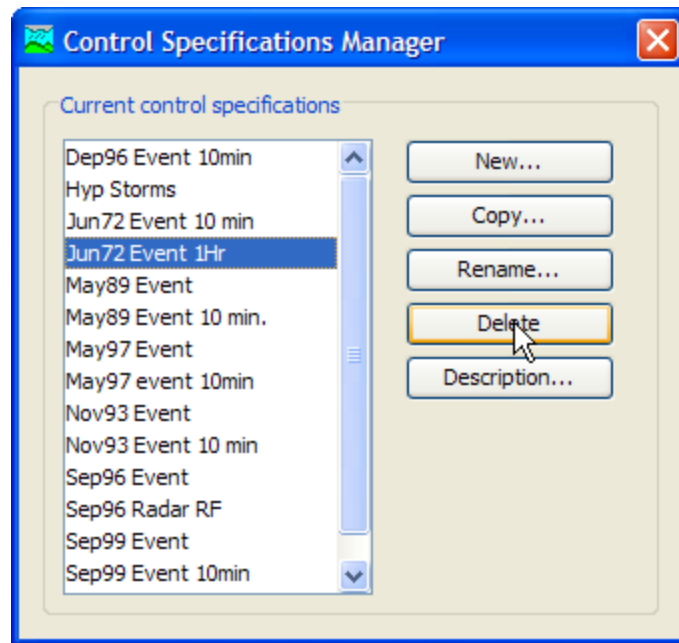

Figure 27. Preparing to delete a control specification from the Control Specifications Manager. A confirmation will be required after pressing the **Delete** button.

The second way to delete is from the "Components" tab of the *Watershed Explorer*. Select the control specifications you wish to delete by clicking on it in the *Watershed Explorer*; it will become highlighted. Keep the mouse over the selected specifications and click the right mouse button (Figure 28). A context menu is displayed that contains several choices including delete. Click the **Delete** command. A window will open where you must confirm that you wish to delete the selected specifications. Press the **OK** button to delete the specifications. If you change your mind and do not want to delete the selected control specifications, press the **Cancel** button or the **X** button in the upper right to return to the *Watershed Explorer*.

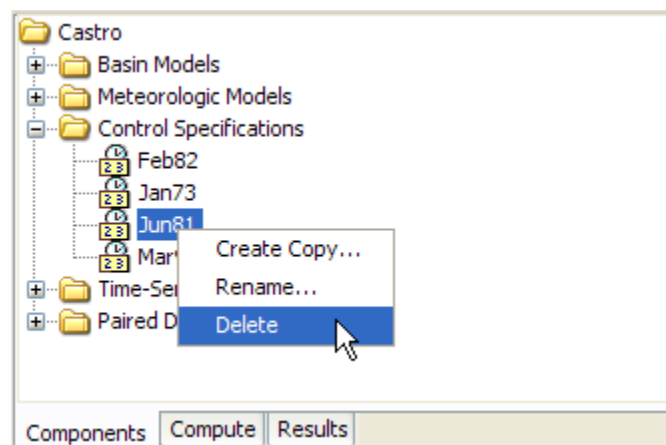

Figure 28. Deleting a control specifications in the Watershed Explorer.



## **Time Window**

Each control specifications sets the time window over which a simulation will be performed. The window is specified using a separate start date, start time, end date, and end time. There is no limit on the length of a time window, or the number of simulation time steps it can contain. The program contains simulation methods suitable for both event and continuous simulation. Whether a particular simulation is considered event or continuous depends on the length of the time window set in the control specifications and the methods chosen in the basin model.

The program is capable of processing dates from 1583 AD through 4000 AD. All dates are processed according to the rules specified in the Gregorian calendar. The format for specifying a date is to use two digits for the day, followed by the three-letter month abbreviation, and finally the four digit year. Two digit years are never used for entering or displaying dates. For example, the date February 8, 1936 should be entered as follows:

08Feb1936

It is very important to use the correct format or the date you enter may be incorrectly interpreted. If the program is not able to interpret a date, the entry field will become blank. The same format is used for both start and end dates, and for dates throughout the program.

The program processes times assuming an arbitrary local time zone that does not observe summer time (daylight savings in the United States). It uses 24-hour clock time instead of AM or PM notation. Time windows can only be entered with minute resolution. Times may range from 00:00 at the beginning of a day to 23:59 at the end. If a time of 24:00 is entered, it is automatically converted to 00:00 on the following day. For example, the time of 2:15:00 PM should be entered as follows:

14:15

It is very important to use the correct format, including the colon, or the time may be incorrectly interpreted. The same format is used for start and end times, and for times throughout the program.

Enter or edit the time window in the *Component Editor* for the control specifications. Access the editor from the *Watershed Explorer* on the "Components" tab by clicking on the desired control specifications icon (Figure 29). Type the date and time information in the appropriate fields.

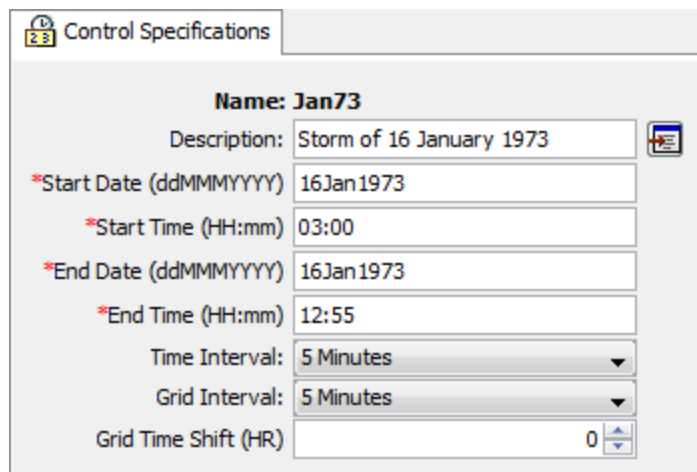

<b>Name: Jan73</b>	
Description:	Storm of 16 January 1973
*Start Date (ddMMYYYY)	16Jan1973
*Start Time (HH:mm)	03:00
*End Date (ddMMYYYY)	16Jan1973
*End Time (HH:mm)	12:55
Time Interval:	5 Minutes
Grid Interval:	5 Minutes
Grid Time Shift (HR)	0

Figure 29. An example of a control specifications component editor.

### Time Interval

Each control specifications includes the time interval that will be used to perform computations during a simulation. The same interval will be used when viewing time-series results from the simulation. In some cases, computations may be carried out at a shorter time interval and results interpolated to the interval specified in the control specifications. Some methods in the basin model have parameters that are sensitive to time interval. Those parameters have to be estimated with knowledge of the time interval in the control specifications.

Time-series gage data and grid data are interpolated to the time interval during a simulation. The original data stored for the gage or grid is not altered; the available data is interpolated as part of the simulation process and is not retained. The interpolation is performed linearly in time between the available data points.

Specify the time interval in the *Component Editor* for the control specifications (Figure 29). Access the editor from the *Watershed Explorer* on the Components tab by clicking on the desired control specifications icon. Select the desired time interval from the list of available choices. The possible choices range from 1 minute to 1 day.

It is important that any minutes included in a start or end time be an integer multiple of the time interval. For example, if the time interval were chosen to be 10 minutes, then the start or end time could be 10:00, 10:10, 10:20 or other multiples of 10 minutes. For the same time interval, the start or end time could not be 10:07 since that is not an integer multiple of the time interval.

### **Gridded Data Output Interval**

All of the general time-series results computed during a simulation use the time interval specified in the Control Specifications. The time interval also controls the solution of the equations that produce the values seen in the time-series results. In general the equations and the results are linked by using the same time interval as specified in the Control Specifications.

Some of the methods available in the subbasin element are gridded, and consequently calculate results for each grid cell within a subbasin. A number of time-series results are available for these methods. The values in each time-series represent an area-weighted average of all the grid cells in the subbasin. That is, the value shown for a particular time interval is the area-weighted average over all the grid cells in the subbasin during that time interval. These results are valuable for showing the general trends over the whole subbasin.

Some of the gridded simulation methods are also capable of storing gridded results. These gridded results represent the basis of the area-weighted averages produced in the time-series results. The gridded results are valuable for showing the heterogeneous processes occurring across the subbasin. However, gridded results require more memory space to store than do time-series results. Storing all of the gridded results for all methods that produce gridded results significantly increases the size of the simulation output files.

Gridded output results are only stored when specifically requested in the program settings which are described in [Chapter 3](#). The Program Settings include an option on the "Results" tab to store the gridded state variable results. Activating this option will make the gridded results from the simulation components available. Activating the output option also adds the gridded data output interval to the *Component Editor*. The gridded data output option will not be visible unless gridded state variables will be output.

The gridded state variables will be stored at the gridded data output interval. However, the internal calculations will be performed at the time interval, and the time-series results will use the time interval. For example, a time interval of 1 hour might be specified for a continuous simulation that spans several months. A gridded data output interval of 1 day could be selected in order to look at the gridded results at the end of each day.

### **Grid Time Shift**

All simulations are completed assuming an arbitrary local time zone. All input data are assumed to be in the local time zone and simulation

results are stored assuming the local time zone. However, gridded precipitation data is typically published with a time zone of GMT. The gridded precipitation method includes an option to shift the data to the local time zone so that it may be aligned with other input data during the simulation. The gridded output results are normally stored in the local time zone. By using the grid time shift, the gridded output results are shifted after the simulation is complete so that the gridded output will align with the original gridded precipitation data.

This feature is considered an interim solution to processing input data with different time zone definitions. Eventually, a complete solution will be implemented where all time-series and gridded input data are labeled with a time zone and the output time-series and gridded simulation results will also be labeled with a time zone.

## ***Importing HEC-1 Files***

The program can import HEC-1 files formatted for the 1981 and newer program versions. Some of the computation options available in HEC-1 are not available in the program. Unrecognized input data is automatically ignored during the import process and reported in the import log. However, the import process is generally successful in separating the input file into component parts for addition to the current project. The job description and initialization data records become control specifications. The hydrograph calculation data records are separated into a basin model and meteorologic model. Precipitation and flow gages are created when necessary. Imported components should always be checked for accuracy.

### ***Selecting and Processing a File***

You can import an existing HEC-1 file into the current project (HEC, 1998). The HEC-1 program used a single file to contain all of the data necessary to perform a simulation. The import process will read the file and create equivalent components for time-series and paired data. It will create a basin model, meteorologic model, and control specifications. It is left to the user to check all of the imported data and create a simulation run to obtain results. Because of more advanced numerical analysis techniques used in the program, results may not match exactly the results obtained with HEC-1.

Begin the process of importing a HEC-1 file by clicking **File** menu and selecting the **Import ⇒ HEC-1 File...** command. An *Import HEC-1 File* window opens where you can specify the HEC-1 file to be imported (Figure 30). If you do not know which file you want to import, you can click the button to the right of the file name field to open a file browser. Use the browser to navigate the file system and find the

correct HEC-1 file. The browser will allow you to select HEC-1 files, which usually end with the DAT or HC1 extensions. Once you have located and selected the desired HEC-1 file, press the **Select** button. If you change your mind about selecting a file, you can press the **Cancel** button or the **X** button in the upper right of the browser to return to the *Import HEC-1 File* window without selecting a file. If you change your mind about importing a HEC-1 file, you can press the **Cancel** button or the **X** button in the upper right of the *Import HEC-1 File* window.

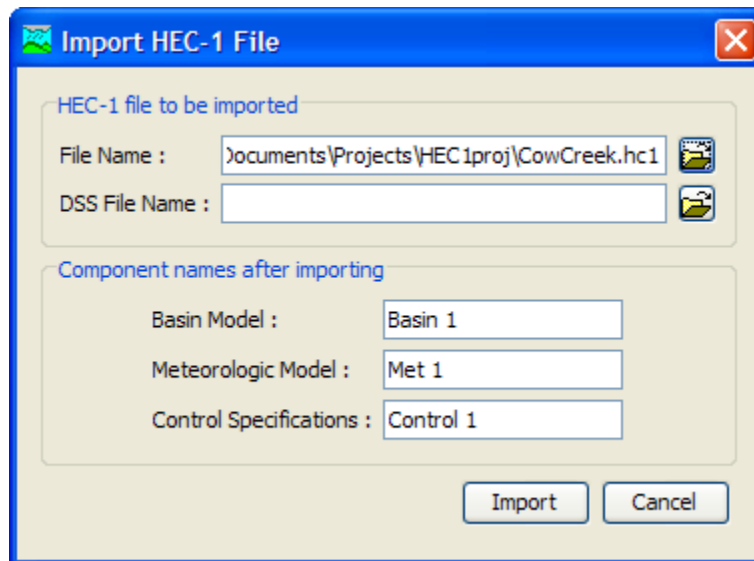

Figure 30. Selecting a HEC-1 file to import. The default names could be changed to better reflect the components.

After you specify the HEC-1 file to import, you must enter the name of the basin model, meteorologic model, and control specifications. You can use the default names that are provided or you can enter your own names. You can always rename the components at a later time. If the HEC-1 file includes ZR records for loading time-series data from a HEC-DSS file, then you should specify the DSS file that contains the data. Without specifying the file, you will have to manually connect to the time-series data. Press the **Import** button when you have finished specifying the HEC-1 file name to import, and the names of the three components. You cannot import a HEC-1 file unless the file name and all three component names are specified. When you press the **Import** button, the import process will read the HEC-1 file and create the appropriate parts of the three components.

### ***Unsupported Features***

Most of the features in the HEC-1 program are also available in this program. Some features related to economic estimates were not incorporated into this program because they are inconsistent with

modern engineering analysis methods for risk-based design. Other features have not been added to this program because they use old numerical algorithms that have been replaced by superior methods in this program and no direct translation is available. Other features may be added to this program in the future. The so-called cards from HEC-1 that are not supported during import are shown in Table 13. An error message will be displayed if any of those cards are encountered.

*Table 13. Unsupported HEC-1 records that cannot be processed during import along with possible alternatives.*

<b>Record Identifier</b>	<b>Alternative</b>
IO, VS, VV	The program automatically writes all computed time-series data to the project DSS file. Complete summary tables and time-series tables are available at all hydrologic elements. There is no need to control the output level.
JP, KP	The program does not currently compute multiple simulation runs simultaneously.
JR	The simulation run includes a precipitation or flow ratio capability but only one ratio is provided. You will need to create a separate simulation run for each ratio. See the section <a href="#">Precipitation and Flow Ratios</a> .
JD	Depth-area analyses provide an equivalent capability with superior accuracy, but there is no direct conversion. See the chapter <a href="#">Depth-Area Reduction</a> .
OU, OR	Optimization trials provide an equivalent capability for estimating loss rate method, transform method, baseflow method, and routing method parameters but there is no direct conversion. See the chapter <a href="#">Model Optimization</a> .
OS, OF, OO, DO, DC, DD, SO, SD, WO, WC, WD	There is no capability to automatically estimate optimal sizes for flood control system components based on economic factors. Risk-based design procedures should be used to size system components.
HB	There is currently no capability to balance computed hydrographs.
HL	The basin model includes a setting to compute local flow at junctions that is similar. See the section <a href="#">Local Flow</a> .
HS	The specified release reservoir routing method provides similar capability, but there is currently no direct conversion. See the section <a href="#">Specified Release Routing</a> .

Table 14. Continued

Record Identifier	Alternative
KF	All computed results are stored in the project DSS file using double precision. There is no need to specify output format.
LM, LH	The exponential-snowmelt and Holtan loss rate methods are not currently available.
MA, MC, MT, MS, MD, MW	There is a temperature index snowmelt capability in the program that is similar, but there is no direct conversion. See the section <a href="#">Temperature Index</a> .
PM	The HMR52 precipitation method provides an equivalent capability, but there is currently no direct conversion. See the section <a href="#">HMR 52 Storm</a> .
QP	Pattern hydrographs for local inflow are not needed because of how the routing optimization is implemented.
RC	Normal depth routing to determine the modified Puls storage-outflow curve is not supported. Channel data are converted to the Muskingum-Cunge method.
RL	Channel losses may be specified using a constant rate or percolation method, but there is currently no direct conversion. See the section <a href="#">Selecting a Gain/Loss Method</a> .
UA	The Clark transform method does include an optional time-area curve, but there is currently no direct conversion. See the section <a href="#">Clark Unit Hydrograph Transform</a> .
WP, WR	The head-discharge pump included in the reservoir provides a similar capability, but there is no direct conversion. See the section <a href="#">Head-Discharge Pump</a> .

## References

Hydrologic Engineering Center. June 1998. HEC-1 Flood Hydrograph Package: User's Manual. U.S. Army Corps of Engineers, Davis, CA.

Hydrologic Engineering Center. October 1994. HEC-DSS User's Guide and Utility Manuals: User's Manual. U.S. Army Corps of Engineers, Davis, CA.

Hydrologic Engineering Center. March 1984. HMR52 Probable Maximum Precipitation (Eastern United States): User's Manual. U.S. Army Corps of Engineers, Davis, CA.

This Page Left Blank



## CHAPTER 5

# *Shared Component Data*

Hydrologic simulation requires a wealth of data that is used as initial conditions, boundary conditions, or parameters. A large portion of the data is measurements of atmospheric conditions, such as precipitation, temperature, and solar radiation. Still significant are storage curves, rating curves, and cross sections.

### *Time-Series Data*

Hydrologic models often require time-series of precipitation data for estimating basin-average rainfall. A time-series of flow data, often called observed flow or observed discharge, is helpful for calibrating a model and is required for optimization. Other kinds of time-series data are used as well. Time-series data is stored in a project as a gage. The program separates different types of data with different gage types. Gage data only has to be entered one time. The gages are part of the project and can be shared by multiple basin or meteorologic models.

#### *Creating a New Gage*

A new gage is created using the time-series data manager. To access the manager, click on the **Components** menu and select the **Time-Series Data Manager** menu command (Figure 31). The manager can remain open while you perform tasks elsewhere in the program. You can close the manager using the **X** button in the upper right corner. At the top of the manager is a **Data Type** menu. This menu lets you select one of the time-series data types supported by the program. Refer to **Error! Reference source not found.** for a complete list of time-series data types. When a data type is selected, the manager will show all time-series data of the same type. The buttons to

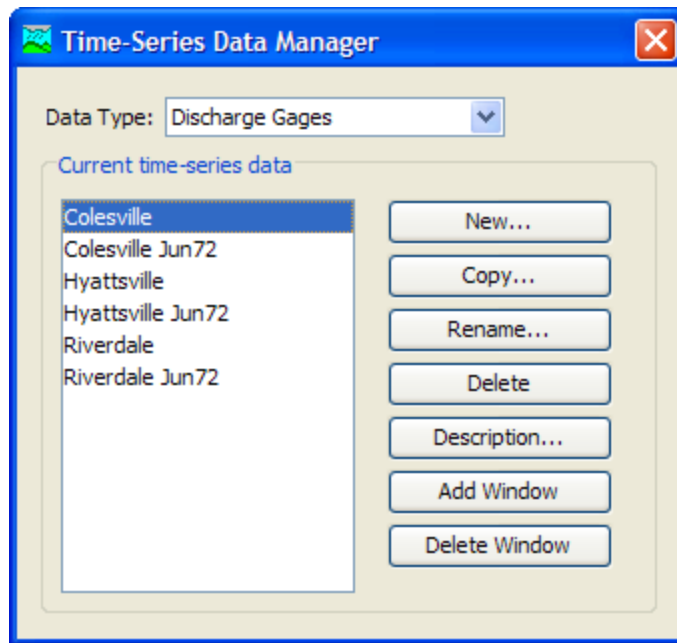

Figure 31. Time-Series Data Manager accessed from the *Components* menu.

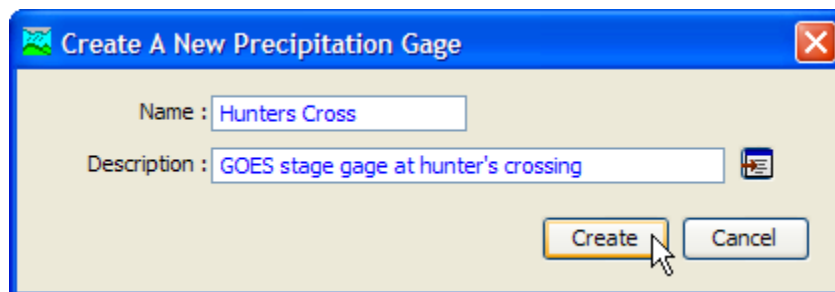

Figure 32. Creating a new discharge gage after pressing the *New...* button in the Time-Series Data Manager.

the right of the time-series data list can be used to manage existing data or create new data. To create a new time-series gage, press the **New...** button. After you press the button a window will open (Figure 32) where you can name and describe the new gage. A default name is provided for the new gage; you can use the default or replace it with your own choice. A description can also be entered. If the description is long, you can press the button to the right of the description field to open an editor.

The editor makes it easy to enter and edit long descriptions. When you are satisfied with the name and description, press the **Create** button to finish the process of creating the new time-series gage. You cannot press the **Create** button if no name is specified. If you change your mind and do not want to create a new time-series gage, press the **Cancel** button or the **X** button in the upper right to return to the time-series data manager.

## Copying a Gage

There are two ways to copy a time-series gage. Both methods for copying a gage create an exact duplicate with a different name. Once the copy has been made it is independent of the original and they do not interact.

The first way to create a copy is to use the time-series data manager, which is accessed from the **Components** menu. First, select the data type of the time-series gage you want to copy from the **Data Type** menu. Then, select the time-series gage you want to copy by clicking on it in the list of current time-series gages. The selected gage is highlighted after you select it. After you select a gage you can press the **Copy...** button on the right side of the window. A new window will open where you can name and describe the copy that will be created (Figure 33). A default name is provided for the copy; you can use the default or replace it with your own choice.

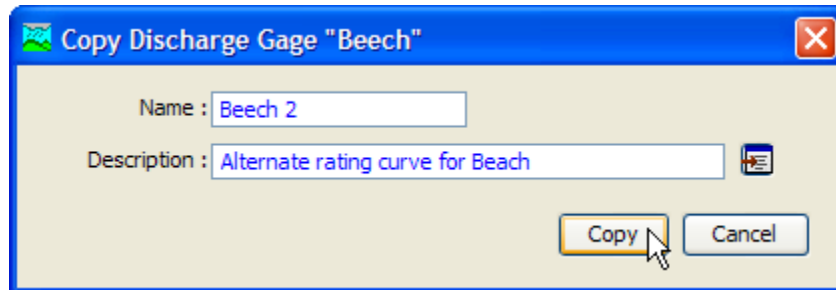

Figure 33. Creating a copy of a gage after pressing the *Copy...* button in the *Time-Series Data Manager*.

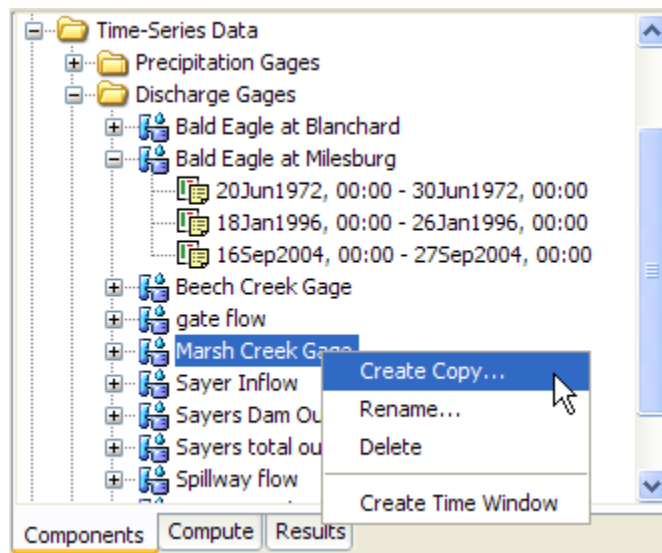

Figure 34. Creating a copy of a gage by selecting it in the *Watershed Explorer* and using the right-mouse menu.

A description can also be entered; if it is long you can use the button to the right of the description field to open an editor. When you are satisfied with the name and description, press the **Copy** button to finish the process of copying the selected time-series gage. You cannot press the **Copy** button if no name is specified. If you change your mind and do not want to copy the selected gage, press the **Cancel** button or the **X** button in the upper right to return to the time-series data manager.

The second way to create a copy is from the *Watershed Explorer*, on the "Components" tab. Move the mouse over the time-series component you wish to copy, then press the right mouse button (Figure 34). A context menu is displayed that contains several choices including copy. Click the **Create Copy...** menu option. A new window will open where you can name and describe the copy that will be created. A default name is provided for the copy; you can use the default or replace it with your own choice. A description can also be entered; if it is long you can use the button to the right of the description field to open an editor. When you are satisfied with the name and description, press the **Copy** button to finish the process of copying the selected time-series gage. You cannot press the **Copy** button if no name is specified. If you change your mind and do not want to copy the gage, press the **Cancel** button or the **X** button in the upper right of the window to return to the *Watershed Explorer*.

### ***Renaming a Gage***

There are two ways to rename a time-series gage. Both methods for renaming a gage changes its name and then all references to the old name are automatically updated to the new name.

The first way to perform a rename is to use the time-series data manager, which you can access from the **Components** menu. First, select the data type of the time-series gage you want to rename from the **Data Type** menu. Then, select the time-series gage you want to rename by clicking on it in the list of current time-series gages. The selected gage is highlighted after you select it. After you select a gage you can press the **Rename...** button on the right side of the window. A window will open where you can provide the new name (Figure 35). You can also change the description at the same time. If the new description will be long, you can

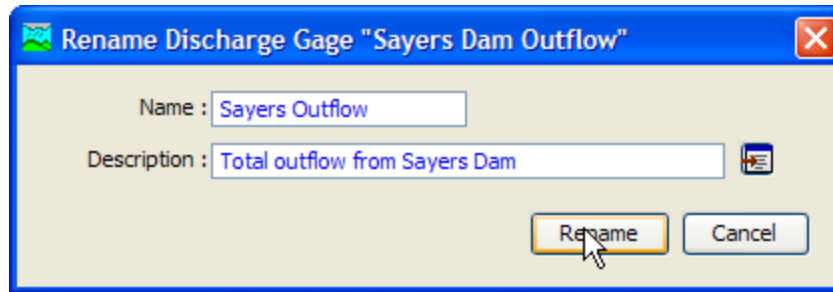

Figure 35. Renaming a gage after pressing the **Rename...** button in the Time-Series Data Manager.

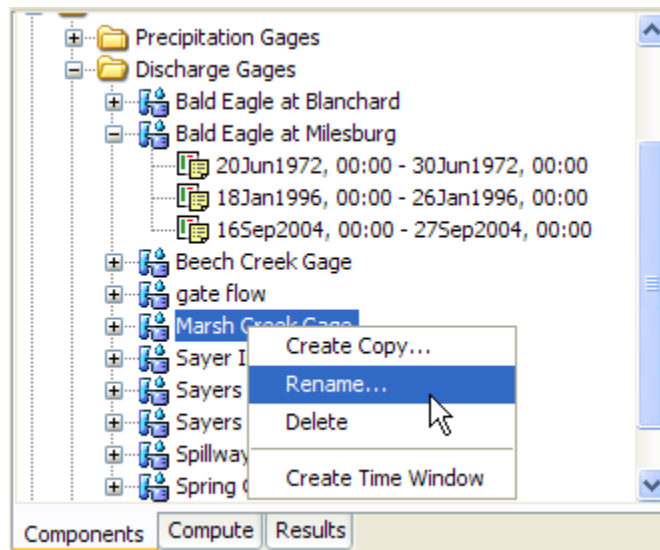

Figure 36. Renaming a gage by selecting it in the Watershed Explorer and then clicking again with the left mouse button to start editing in place.

use the button to the right of the description field to open an editor. When you are satisfied with the name and description, press the **Rename** button to finish the process of renaming the selected time-series gage. You cannot press the **Rename** button if no name is specified. If you change your mind and do not want to rename the selected gage, press the **Cancel** button or the **X** button in the upper right of the window to return to the time-series data manager.

The second way to rename is from the *Watershed Explorer*, on the "Components" tab. Move the mouse over the time-series component you wish to rename, then press the right mouse button (Figure 36). A context menu is displayed; select the **Rename...** command and the highlighted name will change to editing mode. You can then move the cursor with the arrow keys on the keyboard or by clicking with the mouse. You can also use the mouse to select some or all of the name. Change the name by typing with the keyboard. When you have finished changing the name, press the **Enter** key to finalize your

choice. You can also finalize your choice by clicking elsewhere in the *Watershed Explorer*. If you change your mind while in editing mode and do not want to rename the selected gage, press the **Escape** key.

### **Deleting a Gage**

There are two ways to delete a time-series gage. Both methods for deleting a gage will remove it from the project and then automatically update all references to that gage. Once a gage has been deleted it cannot be retrieved or undeleted. Any references to the deleted gage will switch to using no gage, which is usually not a valid choice during a simulation. At a later time you will have to go to those components and manually select a different gage.

The first way to perform a deletion is to use the time-series data manager, which you can access from the **Components** menu. First, select the data type of the time-series gage you want to delete from the **Data Type** menu. Then, select the time-series gage you want to delete by clicking on it in the list of current time-series gages. The selected gage is highlighted after you select it. After you select a gage you can press the **Delete** button on the right side of the window (Figure 37). A window will open where you must confirm that you want to delete the selected gage. Press the **OK** button to delete the gage. If you change your mind and do not want to delete the selected gage, press the **Cancel** button or the **X** button in the upper right to return to the time-series data manager.

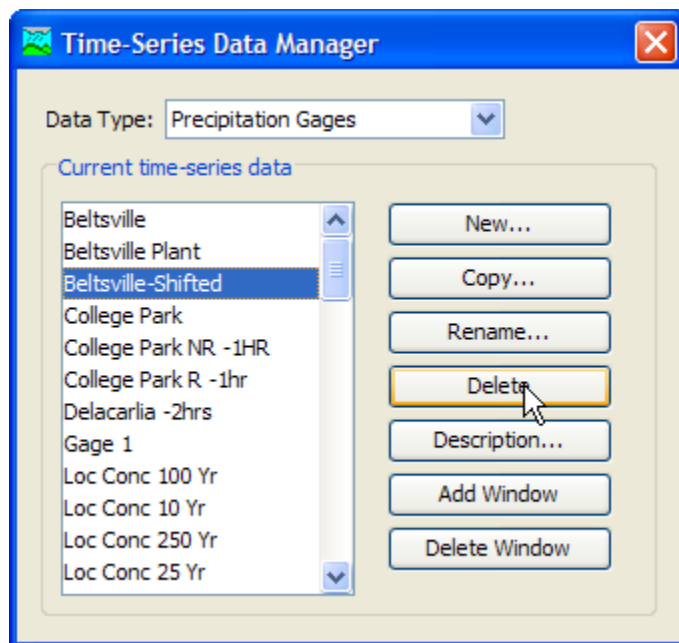

Figure 37. Preparing to delete a gage from the Time-Series Data Manager.

The second way to delete a gage is from the *Watershed Explorer*, on the "Components" tab (Figure 38). Select the time-series gage you want to delete by clicking on it in the *Watershed Explorer*; it will become highlighted. Keep the mouse over the selected gage and click the right mouse button. A context menu is displayed that contains several choices including delete. Click the **Delete** menu option. A window will open where you must confirm that you want to delete the selected gage. Press the **OK** button to delete the gage. If you change your mind and do not want to delete the selected gage, press the **Cancel** button or the **X** button in the upper right to return to the *Watershed Explorer*.

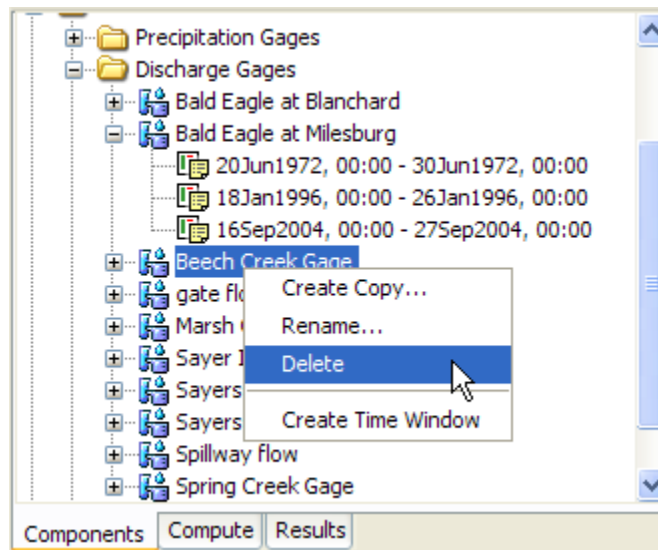

Figure 38. Preparing to delete a gage from the *Watershed Explorer*.

## Time Windows

Time windows are used to separate the time-series data into manageable sections. You may choose to have a separate time window for each event. Alternately you may have several time windows for a continuous record to break it into months or years. You may choose to have a combination of time window types and they may overlap. All time windows use the same data units, time interval, and other properties discussed in the following sections.

The program is capable of processing dates from 1583 AD through 4000 AD. All dates are processed according to the rules specified in the Gregorian calendar. The format for specifying a date is to use two digits for the day, followed by the three-letter month abbreviation, and finally the four digit year. Two digit years are never used for entering or displaying dates. For example, the date October 2, 1955 should be entered as follows:

02Oct1955

It is very important to use the correct format or the date you enter may be incorrectly interpreted. If the program is not able to interpret a date, the entry field will become blank. The same format is used for both start and end dates, and for dates throughout the program.

The program processes times assuming an arbitrary local time zone that does not observe summer time (daylight savings in the United States). It uses 24-hour clock time instead of AM or PM notation. Time windows can only be entered with minute resolution. Times may range from 00:00 at the beginning of a day to 23:59 at the end. If a time of 24:00 is entered, it is automatically converted to 00:00 on the following day. For example, the time of 6:20:00 PM should be entered as follows:

18:20

It is very important to use the correct format, including the colon, or the time may be incorrectly interpreted. The same format is used for start and end times, and for times throughout the program.

There are two ways to create a new time window. The first way is from the *Time-Series Data Manager*, accessed by clicking the **Components** menu and then selecting the **Time-Series Data Manager** command. Select the desired data type, then click on a time-series data component in the list; the component will become highlighted. Press the **Add Window** button to create a new time window. The *Add Time-Series Data Time Window* window will open where you can enter the start date and other information as shown in Figure 39. You can either enter the information manually, or select a control specifications. If you select a control specifications, the start and end time in that control specifications will be used for the new time window. Press the **Add** button to create the new time window. The window will remain open for adding additional time windows. When you are finished, press the **Close** button or the **X** button in the upper corner of the *Add Time-Series Data Time Window*. The second way to create a new time window is directly from the *Watershed Explorer*. Select a time-series component by clicking on it or one of the existing time windows. Keep the mouse over the gage or time window icon and click the right mouse button. A context menu appears as shown in Figure 40; click the **Create Time Window** command to create a new time window. The same window shown in Figure 39 will open for creating a new time window.



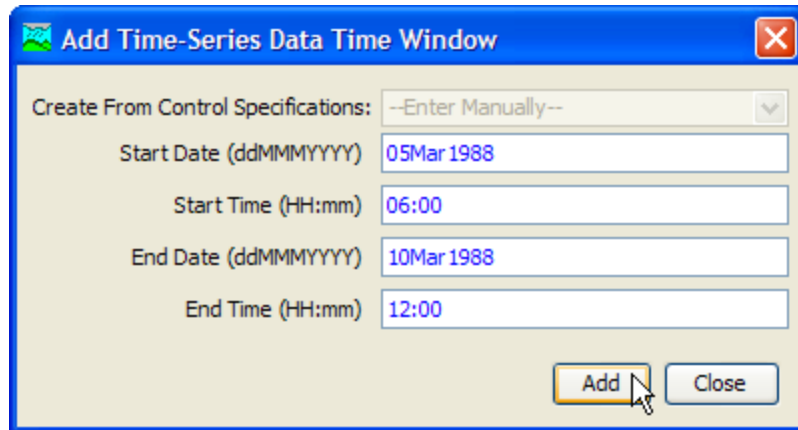

Figure 39. Creating a new time window for a gage, beginning from the Time-Series Data Manager.

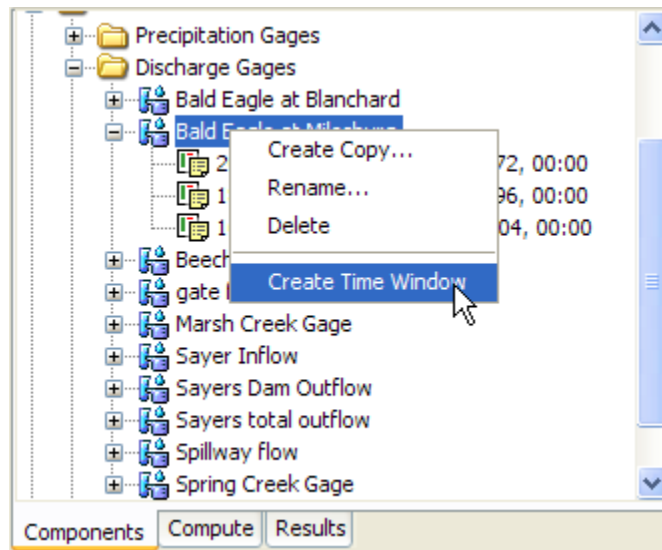

Figure 40. Creating a new time window from the Watershed Explorer.

There are two ways to delete a time window. The first way is from the *Time-Series Data Manager*, accessed by clicking the **Components** menu and then selecting the **Time-Series Data Manager** command. Select the desired data type, then click on a time-series gage in the list; it will become highlighted. Press the **Delete Window** button to delete a time window. The *Delete Time-Series Data Time Window* window will open where you can select the window to delete (Figure 41). Click on the desired window and it will become highlighted. Press the **Delete** button to delete the highlighted time window. If you change your mind and do not want to delete a time window, press the **X** button in the upper corner of the *Delete Time-Series Data Time Window* window. The second way to delete a time window is directly from the *Watershed Explorer*. Select a time window for a time-series gage; it will become highlighted. Keep the mouse over the time window icon and click the right mouse button. A context menu appears as shown in

Figure 42; click the **Delete Time Window** command to delete the selected time window.

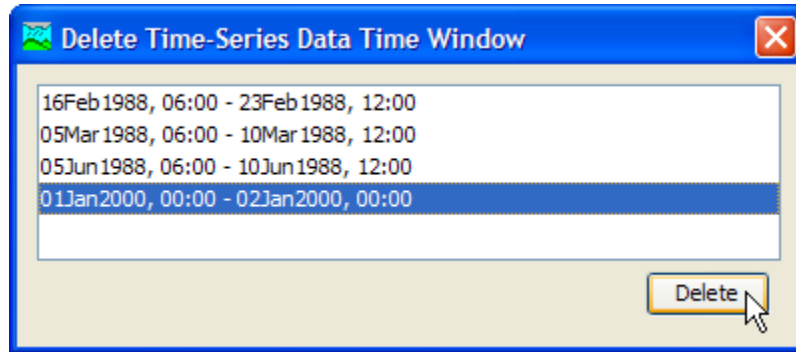

Figure 41. *Selecting a time window to delete from a gage after pressing the **Delete Window** button in the Time-Series Data Manager.*

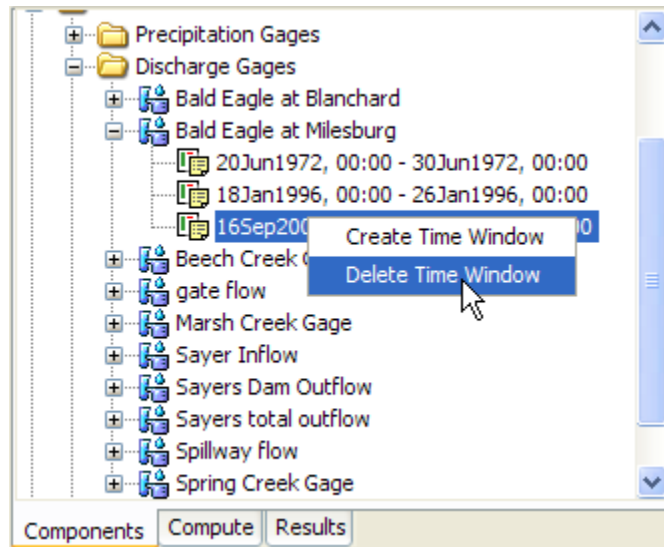

Figure 42. *Deleting a selected time window from a gage after choosing it in the Watershed Explorer.*

The user can change the start date, start time, end date, and end time of an existing time window. Use the *Watershed Explorer* to select the time window you wish to change. Click on the time window under the correct time-series component. The component will become the selected component and its data will be shown in the *Component Editor* as seen in Figure 43; the "Time Window" tab is automatically selected. Change the start date or other properties to the desired values. Click on a different tab in the *Component Editor* or elsewhere in the program interface to make the changes take affect.

The screenshot shows a software interface for editing a time-series gage. At the top, there are four tabs: 'Time-Series Gage', 'Time Window', 'Table', and 'Graph'. The 'Time Window' tab is selected. Below the tabs, the 'Gage Name' is 'Rogers Flat'. There are four input fields for defining the time window:

*Start Date (ddMMYYYY)	05Mar1988
*Start Time (HH:mm)	06:00
*End Date (ddMMYYYY)	10Mar1988
*End Time (HH:mm)	12:00

Figure 43. Using the time window component editor for a gage to view and edit the start and end time for a window.

## Data Source

The data source determines how the data for a time-series component will be entered. There are three alternative methods for entering the data:

1. The user may enter the time-series values by manually typing each one. A variation of this method is using the clipboard to copy and paste instead of manually typing. This first method is known as "Manual Entry."
2. The user may load data into a Data Storage System (HEC-DSS) file. This method can be facilitated using the program HEC-DSSVue to create individual HEC-DSS files. The gage is linked to the time-series values stored in the file. This second method is known as "Single Record HEC-DSS."
3. The user may store alternative versions of the time-series values in a HEC-DSS file. This method is used exclusively for forecasting operations with the Corps Water Management System (CWMS) and planning studies with the Watershed Analysis Tool (HEC-WAT). This third method is known as "Multiple Record HEC-DSS."

The selected data source will determine how the time-series values are entered. The values may be manually typed or linked to a HEC-DSS file. Compare Figure 44 and Figure 45 to see the differences in specifying the data sources.

The screenshot shows the 'Time-Series Gage' component editor. The 'Gage Name' is 'Rogers Flat'. The 'Description' is 'Met station at Roger's Flat park ranger station'. The 'Data Source' is 'Manual Entry'. The 'Units' are 'Celsius'. The 'Time Interval' is '15 Minutes'. The 'Elevation (M)' is '1280'. The 'Ref Height (M)' is '10.0'.

Figure 44. Component editor for a temperature gage with manually-entered data. Of the different data types, only temperature gages have elevation.

The screenshot shows the 'Time-Series Gage' component editor. The 'Gage Name' is 'Fire Station'. The 'Description' is 'Foorhill Street fire station'. The 'Data Source' is 'Single Record HEC-DSS'. The '\*DSS Filename' is 'C:\Users\q0hecwas\Documents\Projects\HMSpr'. The '\*DSS Pathname' is '//Fire Station/PRECIP-INC//15MIN/GAGE/'. The 'Units' are 'Incremental Millimeters'. The 'Time Interval' is '15 Minutes'. The 'Latitude Degrees' is '37', 'Latitude Minutes' is '42', and 'Latitude Seconds' is '7'. The 'Longitude Degrees' is '122', 'Longitude Minutes' is '4', and 'Longitude Seconds' is '48'.

Figure 45. Component editor for a precipitation gage retrieving data from a Data Storage System (HEC-DSS) file. Of the different data types, only precipitation gages have latitude and longitude.

## Data Units

The data units can only be selected for a manual entry time-series gage (Figure 44); they are retrieved automatically for both HEC-DSS options (Figure 45). Most types of time-series data have only two options for units; one for the system international unit system and one for the U.S. customary unit system. For example, discharge gages can use cubic meters per second (M<sup>3</sup>/S) or cubic feet per second (CFS).

The precipitation time-series type has additional options for specifying incremental or cumulative data. The units available in the "Units" field will depend on the time-series type of the selected component. All time windows defined for a time-series component must use the same data units.

Generally you should choose the data units before entering any data for the gage. However, if you change the units after entering data, the data will be adjusted to the new units. There is no units conversion during the adjustment. The values are all kept the same but the assigned units are changed. This is helpful when the data is entered without first checking to make sure the data units are in the desired unit system.

Select the data units for a time-series gage using the *Component Editor*. Access the editor by selecting a time-series gage in the *Watershed Explorer*. The "Time-Series Gage" tab in the *Component Editor* will display the data units if the manual entry option is selected.

### ***Time Interval***

The time interval can only be selected for a manual entry time-series gage (Figure 44); it is retrieved automatically for both HEC-DSS options (Figure 45). An interval must be selected from the available choices that range from 1 minute to 1 day. All time windows defined for a time-series component must use the same time interval.

Generally you should choose the time interval before entering any data for the component. However, if you change the time interval after entering data, the data will be adjusted to the new time interval. When the time interval is made shorter, the data for each time window will be adjusted so that it still begins at the start of the time window. The data will have the new, shorter time interval and there will be missing data from the last specified value to the end of the time window. When the time interval is made longer, the data for each time window will be adjusted so that it still begins at the start of the time window. The data will have the new, longer time interval and the end of the time window will be advanced so that no data is lost.

Select the time interval for a time-series gage using the *Component Editor*. Access the editor by selecting a time-series gage in the *Watershed Explorer*. The "Time-Series Gage" tab in the *Component Editor* will display the time interval if the manual entry option is selected.

### ***Elevation***

Certain atmospheric variables show a strong trend with elevation. Air pressure and air temperature both decrease as the elevation increases. Relative humidity increases as the elevation increases. The physics of water and air can be used to develop relationships for how these variables change with elevation. Therefore, calculating atmospheric variables at a location in the watershed requires both the elevation where the measurement was performed and the elevation where the variable should be calculated. The elevation must be entered for data types that require it. In general, the ground surface elevation (above sea level) at the measurement site is used. The value may be entered as either meters or feet, depending on the unit system of the gage. The requirements for entering latitude and longitude are shown in Table 14.

### ***Reference Height***

Some atmospheric variables change dramatically near the ground surface. Windspeed is very close to zero at the ground surface and increases as distance above the ground increases. Air temperature and relative humidity change significantly with distance above a snow covered surface. Therefore, calculating these atmospheric variables at the ground surface requires information about the height above the ground where the measurements were performed. While it is common for meteorologic instruments to be mounted on a tower 10 meters above the ground surface, other distances may be used at some installations. The instrument reference height must be entered for data types that require it. The value may be entered as either meters or feet, depending on the unit system of the gage. The requirements for entering latitude and longitude are shown in Table 14.

### ***Latitude and Longitude***

The most important atmospheric variable in hydrology is precipitation. Developing an accurate representation of a storm is critical to accurately simulating discharge throughout the watershed. Precipitation gages measure the rainfall at discrete locations within and adjacent to the watershed. Interpolation methods estimate precipitation continuously across the watershed based on the measured rainfall. The methods require a precise description of the location of each precipitation gage. The location is specified for each gage as the latitude and longitude. The latitude and longitude may be entered either as decimal degrees or as a triplet of degrees, minutes, and seconds. The method of entering the latitude and longitude is configured in the Program Settings which are described in [Chapter 3](#).

The requirements for entering latitude and longitude are shown in Table 14.

The degrees, minutes, and seconds are specified separately for the latitude and longitude. In general you should only specify the whole degrees and whole minutes. You can choose to specify whole or fractional seconds. If you enter more than 60 minutes or more than 60 seconds, the program will automatically adjust the degrees, minutes, or second as necessary to have 60 or fewer minutes and 60 or fewer

*Table 14. Requirements for entering additional properties for gages.*

<b>Time-Series</b>	<b>Elevation</b>	<b>Reference Height</b>	<b>Latitude Longitude</b>
Precipitation			X
Discharge			
Stage			
Temperature	X	X	
Solar Radiation			
Windspeed		X	
Air pressure	X		
Humidity	X	X	
Altitude			
Crop Coefficient			
Snow Water Equivalent			
Sediment Load			
Concentration			
Percent			
Evapotranspiration			
Sunshine			

seconds. For example, if you entered 120 degrees and 64 minutes, the program would convert that data to 121 degrees and 4 minutes. A similar adjustment is made when the number of seconds is greater than 60. Alternately, you can specify the latitude and longitude in decimal degrees. In this case only the input for degrees is shown. Instead of entering a value such as 121 degrees, 4 minutes, and 17 seconds, a value in decimal degrees can be entered as 121.07139 degrees. Change the format for displaying and entering latitude and longitude in the program settings which are described in [Chapter 3](#). The setting is found on the "General" tab.

General cartography conventions use negative longitude degrees in the Western hemisphere and positive longitude degrees in the Eastern hemisphere. Negative latitude degrees are used in the Southern hemisphere and positive latitude degrees are used in the Northern hemisphere. These conventions may be used with the program. However, if all locations are in the same quarter sphere, the positive and negative convention can be safely ignored.

### **Manual Entry**

Manual entry is the simplest way to get data values for a time-series gage. The values are manually typed for each date and time. All of the data should be reviewed after entry to verify accurate typing. If no value was recorded for a date and time, then the value should be left blank. The program does not automatically fill in missing data. Data recovery should be considered for extended periods of missing data.

Manual entry can also be used in combination with the clipboard to transfer data values from another computer program. Time-series values may be stored in a spreadsheet or other program. The values can be selected in the other program and copied to the clipboard. The values copied to the clipboard can be pasted in HEC-HMS. Using the clipboard can save a significant amount of manual typing and reduce errors when the time-series values are available in another program.

Manual entry time-series values are automatically stored in a HEC-DSS file in the project directory. The program uses the name of the gage to create a HEC-DSS file for storing the manual entry data. Manual entry values can be entered and then edited as many times as necessary to correct typing errors. Each time the data values are modified manually by the user, the data is automatically updated in the HEC-DSS file. One benefit of using a HEC-DSS file as an automatic storage solution is that the file can be reduced for other modeling projects.

### **Single Record HEC-DSS**

Retrieving time-series data from a HEC-DSS file requires that the data be loaded in a file. The file can be stored on the local computer or on a network server. It is not a good idea to store the file on removable media since the file must be available whenever the time-series component is selected in the *Watershed Explorer*, and during simulations. Data for each gage can be stored in a separate file or one file can contain data for several gages. However, all data for a single time-series gage must be stored in the same HEC-DSS file and use appropriate pathname convention. It is best practice to store the HEC-DSS files holding gage data in the project directory, or a subdirectory



of the project directory. The HEC-DSSVue utility (HEC 2003) can be used to load time-series data into a DSS file.

When the "Single Record HEC-DSS" option is selected, you must specify the filename to use for the time-series component (Figure 45). You may type the complete filename if you know it. To use a file browser to locate the file, press the **Open File Chooser** button to the right of the "DSS Filename" field. The browser allows you to find the desired file but it is limited to locating files with the DSS extension which is required for all Data Storage System files. Once you locate the desired file, click on it in the browser to select it and press the **Select** button. If you change your mind, press the **Cancel** button or the **X** button in the upper corner of the *Select HEC-DSS File* window to return to the *Component Editor*.

You must also specify the pathname to retrieve from the selected HEC-DSS file (Figure 45). You may type the complete pathname if you know it. Each pathname contains six parts called the A-part, B-part, C-part, D-part, E-part, and F-part. The pathname parts are separated with a slash and may contain spaces. The complete pathname, including slashes and spaces, can total up to 256 uppercase characters. The following is an example of an incremental precipitation pathname:

```
//COOPER SMITH DAM/PRECIP-INC/01OCT2001/15MIN/OBS/
```

Because of internal performance considerations, a HEC-DSS file will usually contain multiple records when storing long time-series. The different records will each have all the same pathname parts except for the D-part which indicates the starting time of each record. Any of the record pathnames can be selected and the program will automatically retrieve the correct data depending on the selected time window.

If you do not know the full pathname of the record you wish you use, you can use the pathname browser to specify it. You must select a HEC-DSS file first before the browser is available. Press the **Select DSS Pathname** button to the right of the "DSS Pathname" field to open the browser. The browser initially shows all of the records in the selected HEC-DSS file, organized by pathname in the selection table. You can scroll through the list and select a record pathname by clicking on it. Press the **Select** button at the bottom of the browser to choose that record and return to the *Component Editor*. If you change your mind and do not want to select a record pathname, press the **Cancel** button or the **X** button in the upper right of the *Select Pathname From HEC-DSS File* window. You can reduce the number of record pathnames shown in the selection table using the "Search by Parts" filters. A separate filter selection is shown for each of the six pathname parts. By selecting a choice for a filter, only pathnames that

match that choice will be shown in the selection table. If you make choices in several filters, only pathnames that satisfy all of the choices will be shown in the selection table.

The program observes a very strict set of rules for data type and units within the record pathnames. Rules governing the C-part of the pathname are also enforced. Data cannot be used unless it follows the rules correctly; error messages will be generated if you attempt to use an invalid C-part, data type, or units. The acceptable data types for the different types of time-series data are shown in Table 15. The correct unit labels are shown in Table 16.

*Table 15. Internal DSS data type label for different types of time-series data.*

<b>Time-Series</b>	<b>Label</b>	<b>Description</b>
Precipitation	PER-CUM	The incremental precipitation during each time interval. The C-part should be "PRECIP-INC".
	INST-CUM	The cumulative precipitation at the end of each interval. The C-part should be "PRECIP-CUM".
Discharge	PER-AVER	The average flow rate during each time interval, usually for time steps of 24 hours or longer. The C-part should be "FLOW".
	INST-VAL	The instantaneous flow rate at the end of each time interval. The C-part should be "FLOW".
Stage	PER-AVER	The average depth during each interval, usually time steps of 24 hours or longer. The C-part should be "STAGE".
	INST-VAL	The instantaneous depth at the end of each time interval. The C-part should be "STAGE".
Temperature	PER-AVER	The average temperature, in degrees, during each time interval. The C-part should be "TEMPERATURE".
	INST-VAL	The instantaneous temperature, in degrees, at the end of each time interval. The C-part should be "TEMPERATURE".
Solar Radiation	PER-AVER	The average solar radiation, in power per area, occurring during each time interval. The C-part should be "SOLAR RADIATION".

Table 15. Continued

<b>Time-Series</b>	<b>Label</b>	<b>Description</b>
Windspeed	INST-VAL	The instantaneous windspeed at the end of each time interval. The C-part should be "WINDSPEED".
Air pressure	INST-VAL	The instantaneous air pressure at the end of each time interval. The C-part should be "PRESSURE".
Humidity	INST-VAL	The instantaneous windspeed at the end of each time interval. The C-part should be "HUMIDITY".
Altitude	INST-VAL	The instantaneous windspeed at the end of each time interval. The C-part should be "ALTITUDE".
Crop Coefficient	INST-VAL	The instantaneous crop coefficient, as a dimensionless decimal number, occurring at the end of each time interval. The C-part should be "CROP COEFFICIENT".
Snow Water Equivalent	INST-VAL	The instantaneous snow water equivalent, as a depth at the end of each time interval. The C-part should be "SWE".
Sediment Load	PER-CUM	The total sediment load during each time interval. The C-part should be "LOAD".
Concentration	INST-VAL	The instantaneous concentration at the end of each time interval. The C-part should be "CONC".
Percent	INST-VAL	The instantaneous percent at the end of each time interval. The C-part should be "PERCENT".
Evapotranspiration	PER-CUM	The incremental evapo-transpiration during each time interval. The C-part should be "ET".
Sunshine	PER-AVER	The average sunshine during each time interval. The C-part should be "SUNSHINE HOURS".

Table 16. Internal DSS units label for different types of time-series data.

Time-Series	Label	Description
Precipitation	MM	Millimeters
	IN	Inches
Discharge	M3/S	Cubic meters per second
	CFS	Cubic feet per second
Stage	M	Meters
	FT	Feet
Temperature	DEG C	Degrees centigrade
	DEG F	Degrees Fahrenheit
Solar Radiation	WATT/M2	Watts per square meter
	LANG/MIN	Langleys per minute
Windspeed	KPH	Kilometers per hour
	M/S	Meters per second
	MPH	Miles per hour
	FT/S	Feet per second
Air Pressure	KPA	Kilo pascals
	IN HG	Inches of mercury
Humidity	%	Relative humidity
Altitude	KM	Kilometers above sea level
	MILE	Miles above sea level
Crop Coefficient	UNSPECIF	Dimensionless coefficient
Snow Water Equivalent	MM	Millimeters
	IN	Inches
Sediment Load	TONS	Tons
	TONNES	Metric tonnes
Concentration	MG/L	Milligrams per liter
Percent	%	Percent
Evapotranspiration	MM	Millimeters
	IN	Inches
Sunshine	HR	Hours

### **Multiple Record HEC-DSS**

The multiple record HEC-DSS data source is designed for forecasting operations with the Corps Water Management System (CWMS). The System provides forecasts of future conditions that are used to support operation decisions. It combines meteorologic and hydrologic data

management with engineering simulation models. Meteorologic data includes radar-based precipitation measurements and gage measurements of atmospheric variables. Hydrologic data includes stage and discharge observations among others. Engineering models include hydrology, reservoir operations, hydraulics, and consequences. A typical forecast includes the following steps:

1. Combine recently observed precipitation with forecast precipitation.
2. Link the combined precipitation to HEC-HMS for computing channel flow.
3. Transfer the flow to a reservoir model to determine the best operations for the dam.
4. Connect the reservoir discharge to a hydraulic model to compute downstream flow.
5. Map the downstream flow and estimate economic consequences, and in the case of severe flooding, the potential for life loss.

Forecast operations often consider more than one potential meteorologic forecast. The multiple meteorologic forecasts may result from alternative atmospheric models, atmospheric model ensemble members, or synthetic scenarios such as 150% of the forecast precipitation volume. The multiple record HEC-DSS data source is designed to facilitate the multiple hydrologic simulations necessary to evaluate each meteorologic alternative.

The multiple record data source includes a default selection for HEC-DSS file and pathname. The file and pathname are selected using the same steps already detailed for the Single Record HEC-DSS data source. The default selection will be used during simulations performed in HEC-HMS when it is not part of CWMS. However, when HEC-HMS is used with CWMS, the multiple record data source will be automatically switched to the correct meteorologic alternative based on the overall System configuration.

### **Table**

The data for the current time window is shown in tabular form on the "Table" tab of the *Component Editor* (Figure 46). If you select a time-series gage in the *Watershed Explorer*, only the tab for the "Time-Series Gage" is shown in the *Component Editor*. If you select a time window under a time-series gage in the *Watershed Explorer*, the "Table" tab will be added to the *Component Editor*. Data in the table can be edited if the gage uses manual entry. Data is not editable if the

gage retrieves data from a DSS file. Furthermore, if the gage uses DSS data and no time-series data is available for the specified time window, then the table will not contain any data.

Time (ddMMYYYY, HH:mm)	Temperature (DEG C)
01Jan2000, 00:00	32.0
01Jan2000, 00:15	
01Jan2000, 00:30	
01Jan2000, 00:45	
01Jan2000, 01:00	
01Jan2000, 01:15	
01Jan2000, 01:30	
01Jan2000, 01:45	
01Jan2000, 02:00	29.5
01Jan2000, 02:15	
01Jan2000, 02:30	
01Jan2000, 02:45	
01Jan2000, 03:00	
01Jan2000, 03:15	

Figure 46. Manually entering data for a temperature gage. The fill command will be used to linearly interpolate between two known temperatures.

You can enter all of the data for each time window one value at a time in the table. However, there are tools to help you enter the data quickly. The table includes support for the clipboard. This means you can copy data stored in a spreadsheet or other file and then paste it into the table. You can also use the fill tool to enter or adjust data values in the table. Select the cells in the table you wish to fill and click the right mouse button. A context menu is displayed; select the **Fill...** command. The *Fill Table Options* window opens for you to control the process of filling and adjusting cell values. Options include interpolating the values between the first and last cell in the selection, several choices for interpolating and replacing missing values, copying the first selected cell value to all other selected cells, adding a constant value to all selected cells, and multiplying the selected cell values by a constant. Press the **OK** button to apply your choice, or the **Cancel** button to return to the table without making any changes.

## Graph

The data for the current time window is shown in graphical form on the "Graph" tab of the *Component Editor* (Figure 47). If you select a time-series gage in the *Watershed Explorer*, only the tab for the "Time-Series Gage" is shown in the *Component Editor*. If you select a time

window under a time-series gage in the *Watershed Explorer*, the "Graph" tab will be added to the *Component Editor*. Data in the graph cannot be edited regardless of whether the gage uses manual entry or retrieves data from a DSS file. If no time-series data is available for the specified time window, then the graph will not contain any data.

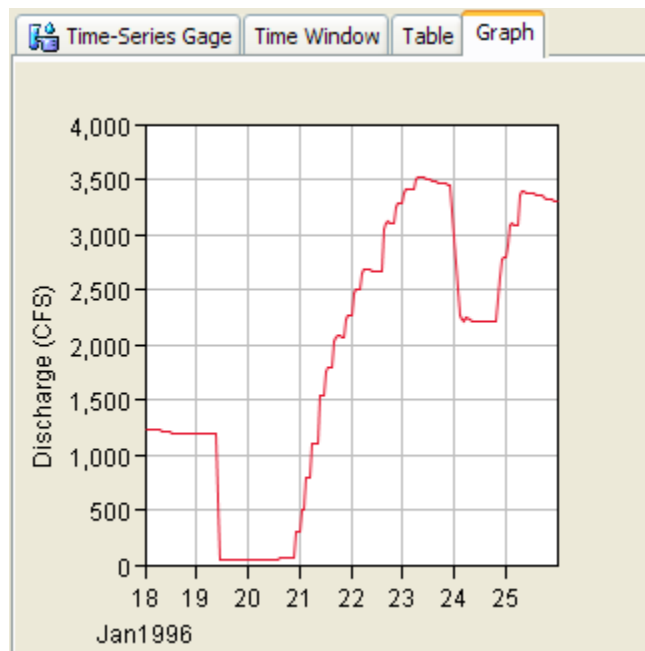

Figure 47. Viewing data for a discharge gage connected to a HEC-DSS file.

## Paired Data

Hydrologic models often require the use of paired data to describe inputs that are functional in form. Functional data defines a dependant variable in terms of an independent variable. For most cases, the function must be monotonically increasing which means it only increases and never decreases. Examples of paired data include unit hydrographs and stage-discharge curves. The program separates different types of paired data with different data types. Paired data only has to be entered one time. The data are part of the project and can be shared by multiple basin or meteorologic models.

### Creating a New Curve

A new curve is created using the paired data manager. To access the manager, click on the **Components** menu and select the **Paired Data Manager** menu item (Figure 48). The manager can remain open while you perform tasks elsewhere in the program. You can close the manager using the **X** button in the upper right corner. At the top of the manager is a **Data Type** menu. This menu lets you select one of the paired data types supported by the program. Refer to **Error!**

**Reference source not found.** for a complete list of paired data types. When a data type is selected, the manager will show all paired data of the same type. The buttons to the right of the paired data list can be used to manage existing data or create new data. To create a paired data curve, press the **New...** button. After you press the button a window will open (Figure 49) where you can name and describe the new curve. A default name is provided for the new curve; you can use the default or replace it with your own choice. A description can also be entered. If the description is long, you can press the button to the right of the description field to open an editor. The editor makes it easier to enter and edit long descriptions. When you are satisfied with the name and description, press the **Create** button to finish the process of creating the new paired data curve. You cannot press the **Create** button if no name is specified. If you change your mind and do not want to create a paired data curve, press the **Cancel** button or the **X** button in the upper right to return to the paired data manager.

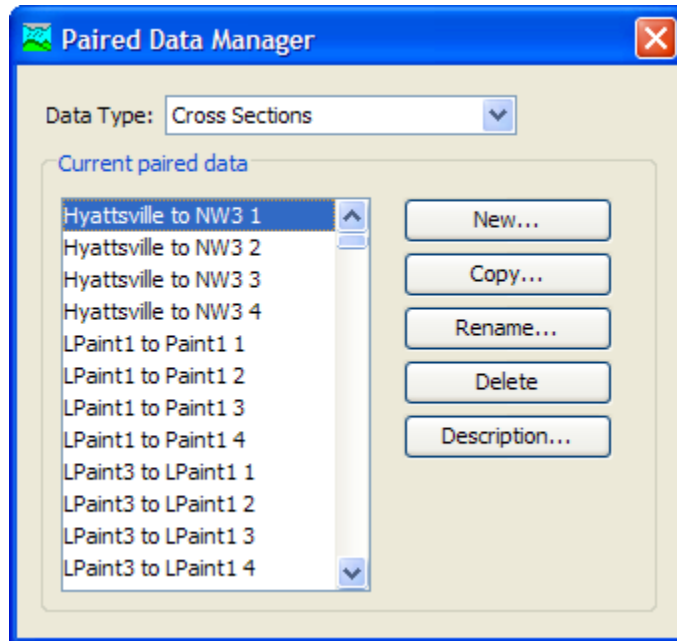

Figure 48. Paired Data Manager accessed from the **Components** menu.

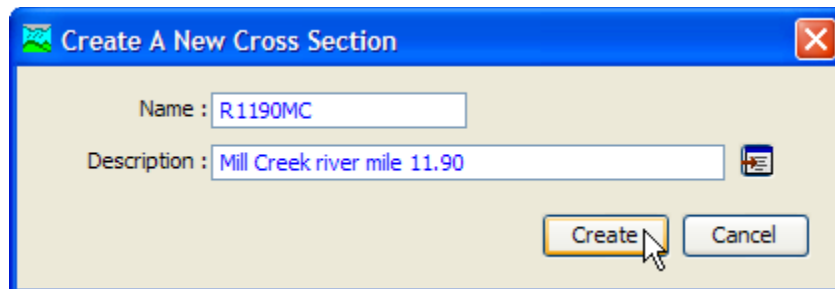

Figure 49. Creating a new cross section after pressing the **New...** button in the Paired Data Manager.



## Copying a Curve

There are two ways to copy a paired data curve. Both methods for copying a curve create an exact duplicate with a different name. Once the copy has been made it is independent of the original and they do not interact.

The first way to create a copy is to use the paired data manager, which is accessed from the **Components** menu. First, select the data type of paired data curve you want to copy from the **Data Type** menu. Then, select the paired data curve you want to copy by clicking on it in the list of current paired data curves. The selected curve is highlighted after you select it. After you select a curve you can press the **Copy...** button on the right side of the window. A new window will open where you can name and describe the copy that will be created (Figure 50). A default name is provided for the copy; you can use the default or replace it with your own choice. A description

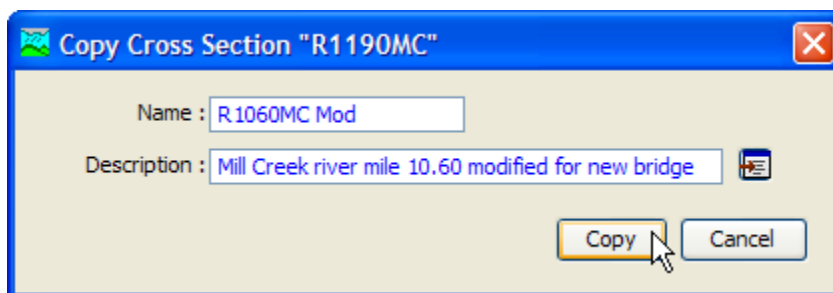

Figure 50. Creating a copy of a gage after pressing the **Copy...** button in the Paired Data Manager.

can also be entered; if it is long you can use the button to the right of the description field to open an editor. When you are satisfied with the name and description, press the **Copy** button to finish the process of copying the selected paired data curve. You cannot press the **Copy** button if no name is specified. If you change your mind and do not want to copy the selected curve, press the **Cancel** button or the **X** button in the upper right to return to the paired data manager.

The second way to create a copy is from the *Watershed Explorer*, on the “Components” tab. Move the mouse over the paired data component you wish to copy, then press the right mouse button (Figure 51). A context menu is displayed that contains several choices including copy. Click the **Create Copy...** menu option. A new window will open where you can name and describe the copy that will be created. A default name is provided for the copy; you can use the default or replace it with your own choice. A description can also be entered; if it is long you can use the button to the right of the description field to open an editor. When you are satisfied with the name and description, press the **Copy** button to finish the process of

copying the selected paired data curve. You cannot press the **Copy** button if no name is specified. If you change your mind and do not want to copy the curve, press the **Cancel** button or the **X** button in the upper right of the window to return to the *Watershed Explorer*.

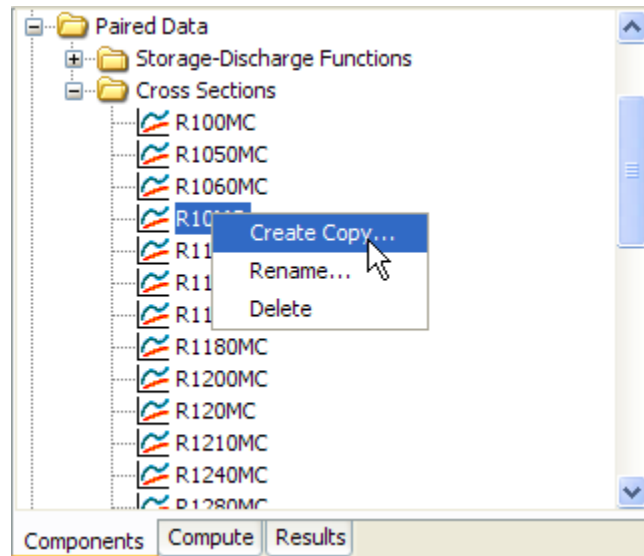

Figure 51. Creating a copy of a cross section by selecting it in the *Watershed Explorer* and using the right-mouse menu.

## Renaming a Curve

There are two ways to rename a paired data curve. Both methods for renaming a curve changes its name and then all references to the old name are automatically updated to the new name.

The first way to perform a rename is to use the paired data manager, which you can access from the **Components** menu. First, select the data type of paired data curve you want to rename from the **Data Type** menu. Then, select the paired data curve you want to rename by clicking on it in the list of current curves. The selected curve is highlighted after you select it. After you select a curve you can press the **Rename...** button on the right side of the window. A window will open where you can provide the new name (Figure 52). You can also change the description at the same time. If the new description will be long, you can use the button to the right of the field to open an editor. When you are satisfied with the name and description, press the **Rename** button to finish the process of renaming the selected paired data curve. You cannot press the **Rename** button if no name is specified. If you change your mind and do not want to rename the selected curve, press the **Cancel** button or the **X** button in the upper right of the window to return to the paired data manager.

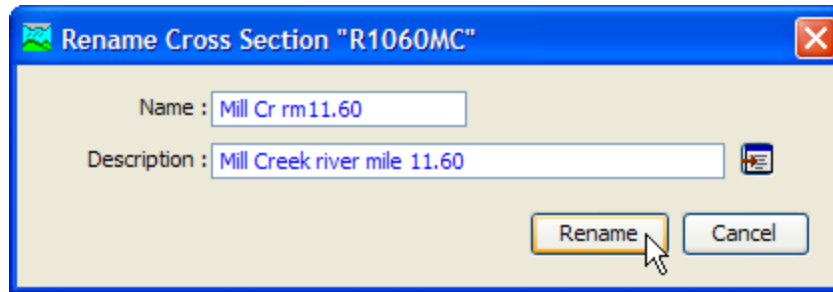

Figure 52. Renaming a cross section after pressing the **Rename...** button in the Paired Data Manager.

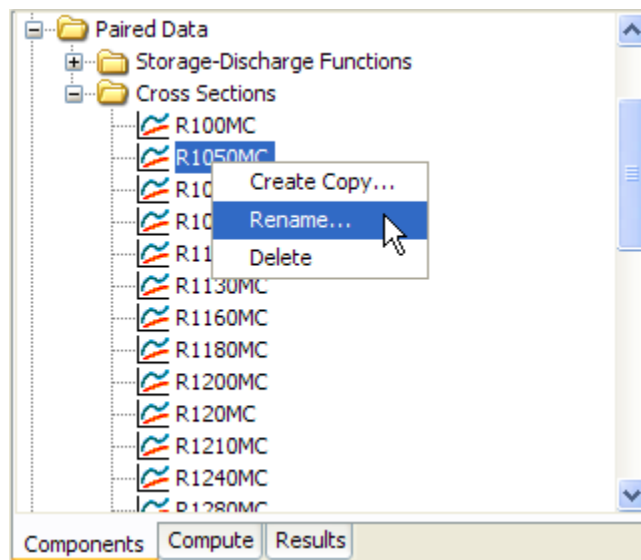

Figure 53. Renaming a cross section by selecting it in the Watershed Explorer and using the right-mouse menu.

The second way to rename is from the *Watershed Explorer*, on the “Components” tab. Move the mouse over the paired data you wish to copy, then press the right mouse button (Figure 53). A context menu is displayed; select the **Rename...** command and the highlighted name will change to editing mode. You can then move the cursor with the arrow keys on the keyboard or by clicking with the mouse. You can also use the mouse to select some or all of the name. Change the name by typing with the keyboard. When you have finished changing the name, press the **Enter** key to finalize your choice. You can also finalize your choice by clicking elsewhere in the *Watershed Explorer*. If you change your mind while in editing mode and do not want to rename the selected curve, press the **Escape** key.

### **Deleting a Curve**

There are two ways to delete a paired data. Both methods for deleting a curve will remove it from the project and then automatically update all references to that curve. Once a curve has been deleted it cannot be

retrieved or undeleted. Any references to the deleted curve will switch to using no curve, which is usually not a valid choice during a simulation. At a later time you will have to go to those components and manually select a different curve.

The first way to perform a deletion is to use the paired data manager, which you can access from the **Components** menu. First, select the data type for the paired data curve you want to delete from the **Data Type** menu. Then, select the curve you want to delete by clicking on it in the list of current curves. The selected curve is highlighted after you select it. After you select a curve you can press the **Delete** button on the right side of the window (Figure 54). A window will open where you must confirm that you want to delete the selected curve. Press the **OK** button to delete the curve. If you change your mind and do not want to delete the selected curve, press the **Cancel** button or the **X** button in the upper right to return to the paired data manager.

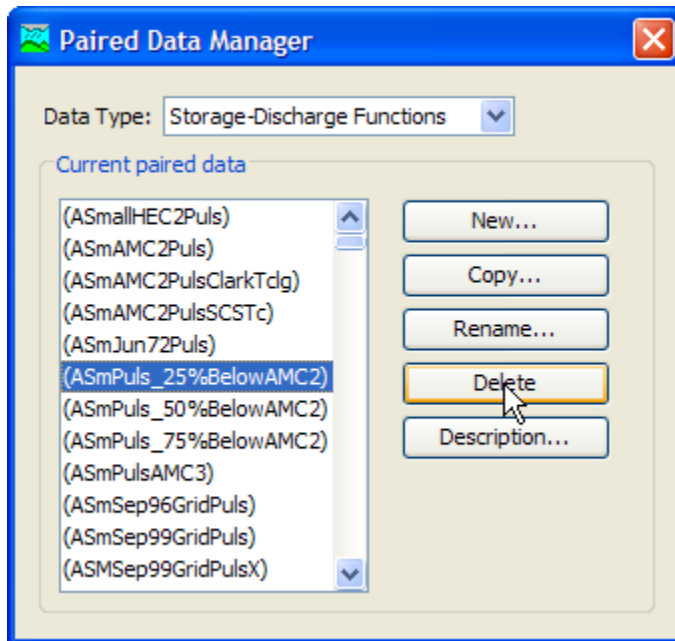

Figure 54. Preparing to delete a cross section from the Paired Data Manager.

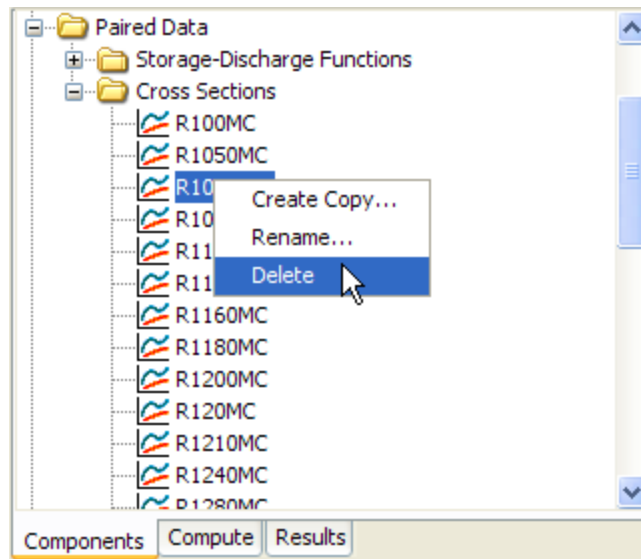

Figure 55. Preparing to delete a cross section from the Watershed Explorer.

The second way to delete a paired data is from the *Watershed Explorer*, on the “Components” tab (Figure 55). Select the curve you want to delete by clicking on it in the *Watershed Explorer*, it will become highlighted. Keep the mouse over the selected curve and click the right mouse button. A context menu is displayed that contains several choices including delete. Click the **Delete** menu option. A window will open where you must confirm that you want to delete the selected curve. Press the **OK** button to delete the curve. If you change your mind and do not want to delete the selected curve, press the **Cancel** button or the **X** button in the upper right to return to the *Watershed Explorer*.

### **Data Source**

The data source determines how the data for a paired data will be stored. Data may be entered manually or retrieved from the Data Storage System (HEC-DSS). Manual entry means that you must enter each of the values in the curve or pattern. Data can be retrieved from a DSS file without having to enter the values, but the data must be correctly loaded into the file. The type of properties you specify for the paired data will be determined by the data source, as discussed in the following sections. Compare Figure 56 and Figure 57 to see the difference in entering data for manual or HEC-DSS data sources.

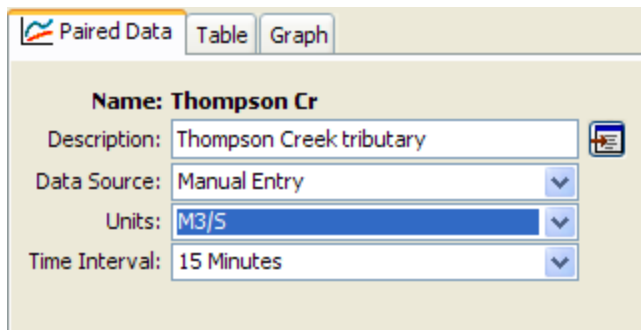

Figure 56. Component editor for a unit hydrograph paired data curve with manually-entered data. Only unit hydrographs have a time interval.

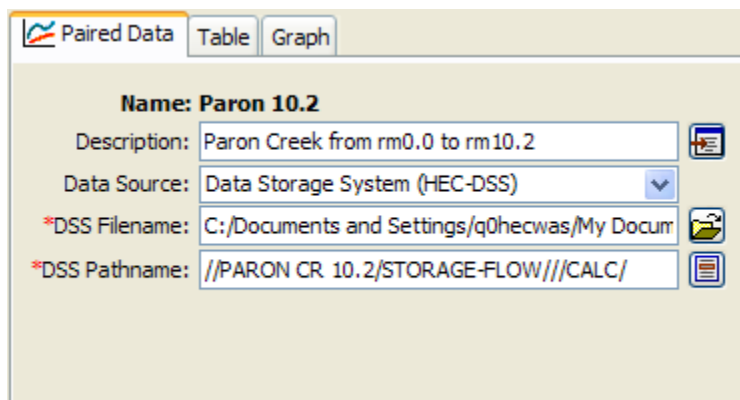

Figure 57. Component editor for a storage-discharge curve retrieving data from a Data Storage System (HEC-DSS) file.

## Data Units

The data units can only be selected for a manual entry paired data (Figure 56); they are retrieved automatically for the DSS option (Figure 57). Paired data have only two options for units; one for the system international unit system and one for the U.S. customary unit system. For example, a storage-discharge curve can use 1000 cubic meters and cubic meters per second (1000M3 - M3/S) or acre feet and cubic feet per second (ACFT - CFS). The units available in the "Units" field will depend on the paired data type of the selected component.

Generally you should choose the data units before entering any data for the component. However, if you change the units after entering data, the data will be adjusted to the new units. There is no units conversion during the adjustment. The values are all kept the same but the assigned units are changed. This is helpful when the data is entered without first checking to make sure the data units are in the desired unit system.

Select the data units for a paired data component using the *Component Editor*. Access the editor by selecting a paired data in the

*Watershed Explorer*. The "Paired Data" tab in the *Component Editor* will display the data units if the manual entry option is selected.

### **Time Intervals**

Unit hydrographs are the only type of paired data that can have a time interval as seen in Figure 56. The time interval can only be selected for a manual entry unit hydrograph; it is retrieved automatically for the DSS option. An interval must be selected from the available choices that range from 1 minute to 24 hours. Generally you should choose the time interval before entering data for the unit hydrograph. However, if you change the time interval after entering data, the data will be adjusted to the new time interval.

Select the time interval for a unit hydrograph paired data using the *Component Editor*. Access the editor by selecting a unit hydrograph paired data in the *Watershed Explorer*. The "Paired Data" tab in the *Component Editor* will display the time interval if the manual entry option is selected.

### **Retrieval From a HEC-DSS File**

Retrieving paired data from a DSS file requires that the data be loaded in a file. The file can be stored on the local computer or on a network server. It is not a good idea to store the file on removable media since the file must be available whenever the paired data is selected in the *Watershed Explorer*, and during computes. It is poor practice to store the data in the project DSS file used for storing simulation results. Data for each paired data can be stored in a separate file or one file can contain data for several components. It is best practice to store the DSS files holding gage data in the project directory, or a subdirectory of the project directory. The HEC-DSSVue utility (HEC 2003) can be used to load paired data into a DSS file.

When the DSS option is selected, you must specify the filename to use for the paired data component (Figure 57). You may type the complete filename if you know it. To use a file browser to locate the file, press the **Open File Chooser** button to the right of the "DSS Filename" field. The browser allows you to find the desired file but it is limited to locating files with the DSS extension which is required for all Data Storage System files. Once you locate the desired file, click on it in the browser to select it and press the **Select** button. If you change your mind, press the **Cancel** button or the **X** button in the upper corner of the *Select HEC-DSS File* window to return to the *Component Editor*.

You must also specify the pathname to retrieve from the selected DSS file (Figure 57). You may type the complete pathname if you know it. Each pathname contains six parts called the A-part, B-part, C-part, D-

part, E-part, and F-part. The pathname parts are separated with a slash and may contain spaces. The complete pathname, including slashes and spaces, can total up to 256 uppercase characters. The following is an example of a storage-discharge curve pathname:

```
//BEAR CREEK/STORAGE-OUTFLOW///COMPUTED/
```

If you do not know the full pathname of the record you wish to use, you can use the pathname browser to specify it. You must select a DSS file first before the browser is available. Press the **Select DSS Pathname** button to the right of the "DSS Pathname" field to open the browser. The browser initially shows all of the records in the specified DSS file, organized by pathname in the selection table. You can scroll through the list and select a record pathname by clicking on it. Press the **Select** button at the bottom of the browser to choose that record and return to the *Component Editor*. If you change your mind and do not want to select a record pathname, press the **Cancel** button or the **X** button in the upper right of the *Select Pathname From HEC-DSS File* window. You can reduce the number of record pathnames shown in the selection table using the "Search by Parts" filters. A separate filter selection is shown for each of the six pathname parts. By selecting a choice for a filter, only pathnames that match that choice will be shown in the selection table. If you make choices in several filters, only pathnames that satisfy all of the choices will be shown in the selection table.

The program observes a preferred order for paired data. For example, storage-outflow is preferred to outflow-storage. However, the program is capable of using data specified backwards from the preferred order. The program does observe a very strict set of rules for data type and units within the record pathnames. Data cannot be used unless it follows the rules correctly; error messages will be generated if you attempt to use an invalid data type or units. The units of both halves of the paired data must be in the same unit system. The acceptable data types for the different types of paired data are shown in Table 17. The correct unit labels are shown in **Error! Reference source not found..**



Table 17. Preferred data order and internal DSS data type label for different types of paired data.

Paired Data	Label	Description
Storage-Discharge	UNT	Defines a storage versus outflow function. The C-part should be "STORAGE-FLOW".
Elevation-Storage	UNT	Defines an elevation versus storage function. The C-part should be "ELEVATION-STORAGE".
Elevation-Area	UNT	Defines an elevation versus area function. The C-part should be "ELEVATION-AREA".
Elevation-Discharge	UNT	Defines an elevation versus discharge function. The C-part should be "STAGE-FLOW".
Inflow-Diversion	UNT	Defines an inflow versus diversion function. The C-part should be "FLOW-DIVERSION".
Diameter-Percentage	UNT	Defines a diameter versus percentage function, also known as a gradation curve. The C-part should be "DIAMETER-PERCENT FINER".
Cross Section	UNT	Defines distance versus elevation function to represent a cross section. The C-part should be "DISTANCE-ELEVATION".
Unit Hydrograph	INST-VAL	Defines a user-specified unit hydrograph. The C-part should be "FLOW-UNIT GRAPH".
Percentage Curve	UNT	Defines a percentage versus percentage function. The C-part should be "PERCENT GRAPH".
Duration-Precipitation	UNT	Defines a time duration versus precipitation depth function. The C-part should be "DURATION-PRECIPIATION".
ATI-Meltrate	UNT	Defines an antecedent temperature index versus meltrate function. The C-part should be "ATI-MELTRATE".
ATI-Coldrate	UNT	Defines an antecedent temperature index versus coldrate function. The C-part should be "ATI-COLDRATE".

Table 17. Continued.

Paired Data	Label	Description
Groundmelt Pattern	INST-VAL	Defines an annual pattern of groundmelt. The C-part should be "GROUNDMELT".
Percent Pattern	INST-VAL	Defines an annual pattern of meltrate. The C-part should be "PERCENT".
Cumulative Probability	UNT	Defines a probability cumulative density function. The C-part should be "PROBABILITY DISTRIBUTION".

Table 18. Internal DSS units for different types of paired data. The unit hydrograph and patterns uses dates in the year 2000.

Paired Data	X-Label	Y-Label	Description
Storage-Discharge	THOU M3	M3/S	Thousands of cubic meters; cubic meters per second.
	ACRE-FT	CFS	Acre-feet; cubic feet per second.
Elevation-Storage	M	THOU M3	Meters; thousand cubic meters.
	FT	ACRE-FT	Feet; acre-feet.
Elevation-Area	M	THOU M2	Meters; thousands of square meters.
	FT	ACRE	Feet; acres.
Elevation-Discharge	M	M3/S	Meters; cubic meters per second.
	FT	CFS	Feet; cubic feet per second.
Inflow-Diversion	M3/S	M3/S	Cubic meters per second; cubic meters per second.
	CFS	CFS	Cubic feet per second; cubic feet per second.
Diameter-Percentage	MM	%	Millimeters; percent finer.
	IN	%	Inches; percent finer.
Cross Section	M	M	Meters; meters.
	FT	FT	Feet; feet.
Unit Hydrograph		M3/S	Cubic meters per second.
		CFS	Cubic feet per second.

Table 18. Continued.

Paired Data	X-Label	Y-Label	Description
Percentage Curve	%	%	Percent; percent.
Duration-	HR	MM	Hours; millimeters
Precipitation	HR	IN	Hours; inches
ATI-Meltrate	DEGC-D	MM/DEG-D	Degree Celsius days; millimeters per degree per day.
	DEGF-D	IN/DEG-D	Degree Fahrenheit days; inches per degree per day.
ATI-Coldrate	DEGC-D	MM/DEG-D	Degree Celsius days; millimeters per Celsius degree per day.
	DEGF-D	IN/DEG-D	Degree Fahrenheit days; inches per Fahrenheit degree per day.
Groundmelt Pattern		MM/DAY	Millimeters per day.
		IN/DAY	Inches per day.
Percent Pattern		%	Percent.
Cumulative Probability			Probability is dimensionless and should have no units specified.

### Table

The data for the current paired data is shown in tabular form on the "Table" tab of the *Component Editor* (Figure 58). Data in the table can be edited if the paired data uses manual entry. Data is not editable if the paired data retrieves data from a DSS file. Furthermore, if the paired data uses DSS data and no data is available, then the table will not contain any data.

Storage (1000 M3)	Discharge (M3/S)
0.0	0.0
100.0	10.0
200.0	50.0
300.0	200.0
450	225
600	240

Figure 58. Manually entering data for a storage-discharge curve.

You can enter all of the data one value at a time in the table. However, there are tools to help you enter the data quickly. The table includes support for the clipboard. This means you can copy data stored in a spreadsheet or other file and then paste it into the table. You can also use the fill tool to enter or adjust data values in the table. Select the cells in the table you wish to fill and click the right mouse button. A context menu is displayed; select the **Fill...** command. The *Fill Table Options* window opens for you to control the process of filling and adjusting cell values. Options include interpolating the values between the first and last cell in the selection, several choices for interpolating and replacing missing values, copying the first selected cell value to all other selected cells, adding a constant value to all selected cells, and multiplying the selected cell values by a constant. Press the **OK** button to apply your choice, or the **Cancel** button to return to the table without making any changes.

## Graph

The data for the current paired data is shown in graphical form on the "Graph" tab of the *Component Editor* (Figure 59). Data in the graph cannot be edited regardless of whether the paired data uses manual entry or retrieves data from an external DSS file. If no data is available, then the graph will not contain any data.

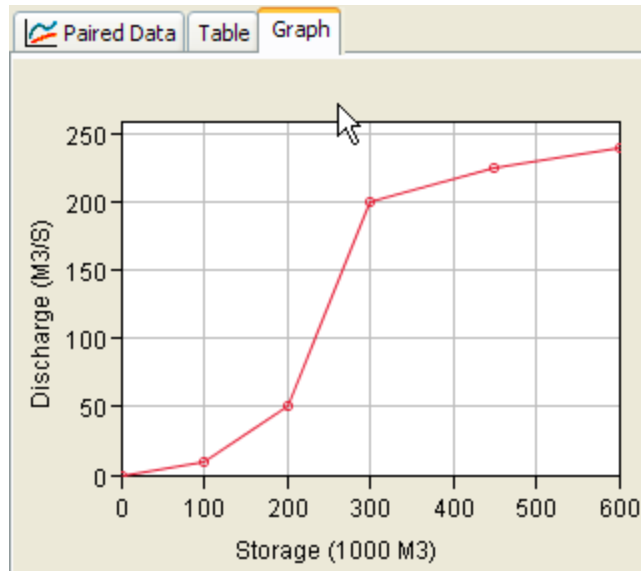

Figure 59. Viewing data for a storage-discharge curve.

## Grid Data

Some of the methods included in the program operate on a grid cell basis. This means that parameters must be entered for each grid cell. It also means that boundary conditions like precipitation must be available for each grid cell. One example of grid data is the SCS curve number grid, which is used as a parameter grid. Another example is the temperature gridset, which is a time-series of grids. The program separates different types of grid data with different data types. Grid data only has to be entered one time. The data are part of the project and can be shared by multiple basin or meteorologic models.

### Creating a New Grid

A new grid is created using the grid data manager. To access the manager, click on the **Components** menu and select the **Grid Data Manager** menu command (Figure 60). The manager can remain open while you perform tasks elsewhere in the program. You can close the manager using the **X** button in the upper right corner. At the top of the manager is a **Data Type** menu. This menu lets you select one of the grid data types supported by the program. Refer to **Error! Reference source not found.** for a complete list of grid data types. When a data type is selected, the manager will show all grid data of the same type. The buttons to the right of the grid data list can be used to manage existing data or create new data. To create a grid, press the **New...** button. After you press the button a window will open (Figure 61) where you can name and describe the new grid. A default name is provided for the grid; you can use the default or replace it with your own choice. A description can also be entered. If the description is

long, you can press the button to the right of the description field to open an editor. The editor makes it easier to enter and edit long descriptions. When you are satisfied with the name and description, press the **Create** button to finish the process of creating the new grid. You cannot press the **Create** button if no name is specified. If you change your mind and do not want to create the grid, press the **Cancel** button or the **X** button in the upper right to return to the grid data manager.

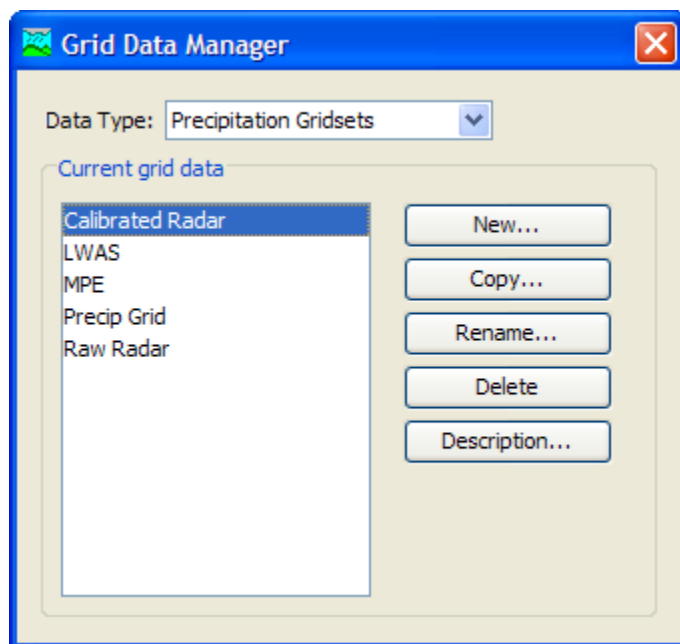

Figure 60. Grid Data Manager accessed from the **Components** menu.

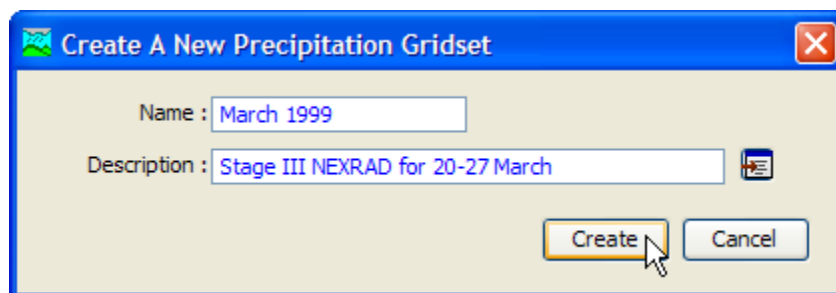

Figure 61. Creating a new precipitation gridset after pressing the **New...** button in the Grid Data Manager.

### **Copying a Grid**

There are two ways to copy a grid. Both methods for copying a grid create an exact duplicate with a different name. Once the copy has been made it is independent of the original and they do not interact.

The first way to create a copy is to use the grid data manager, which is accessed from the **Components** menu. First, select the grid data type

you want to copy from the **Data Type** menu. Then, select the grid you want to copy by clicking on it in the list of current grids. The selected grid is highlighted after you select it. After you select a grid you can press the **Copy...** button on the right side of the window. A new window will open where you can name and describe the copy that will be created (Figure 62). A default name is provided for the copy; you can use the default or replace it with your own choice. A description can also be entered; if it is long you can use the button to the right of the description field to open an editor. When you are satisfied with the name and description, press the **Copy** button to finish the process of copying the selected grid. You cannot press the **Copy** button if no name is specified. If you change your mind and do not want to copy the selected grid, press the **Cancel** button or the **X** button in the upper right to return to the grid data manager.

The second way to create a copy is from the *Watershed Explorer*, on the “Components” tab. Move the mouse over the grid data you wish to copy, then press the right mouse button (Figure 63). A context menu is displayed that contains several choices including copy. Click the **Create Copy...** menu option. A new window will open where you can name and describe the copy that will be created. A default name is provided for the copy; you can use the default or replace it with your own choice. A description can also be entered; if it is long you can use the button to the right of the description field to open an editor. When you are satisfied with the name and description, press the **Copy** button to finish the process of copying the selected grid. You cannot press the **Copy** button if no name is specified. If you change your mind and do not want to copy the grid, press the **Cancel** button or the **X** button in the upper right of the window to return to the *Watershed Explorer*.

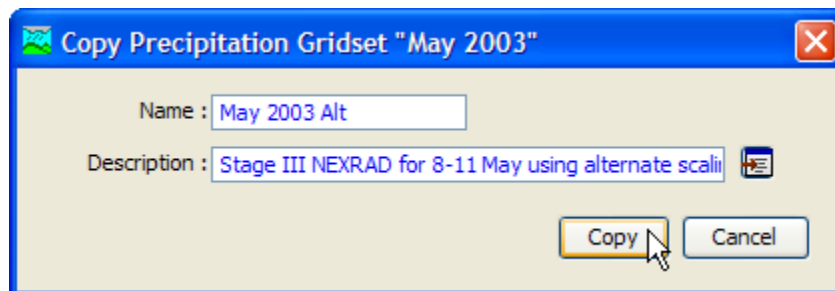

Figure 62. Creating a copy of a precipitation gridset after pressing the **Copy...** button in the Grid Data Manager.

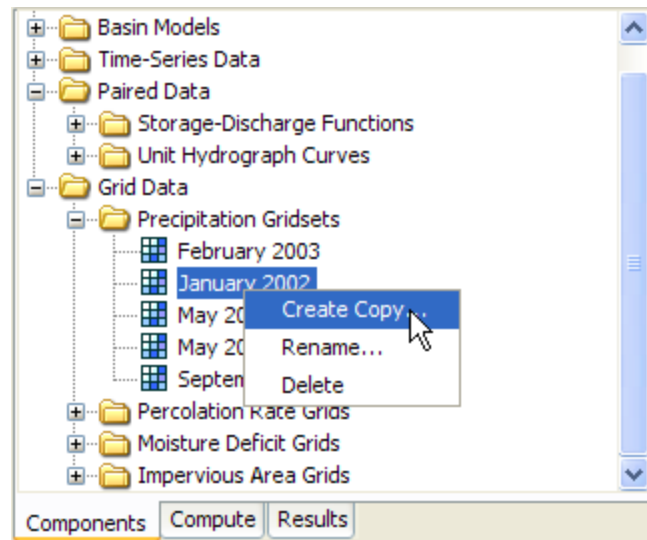

Figure 63. Creating a copy of a grid by selecting it in the Watershed Explorer and using the right-mouse menu.

## Renaming a Grid

There are two ways to rename a grid. Both methods for renaming a grid changes its name and then all references to the old name are automatically updated to the new name.

The first way to perform a rename is to use the grid data manager, which you can access from the **Components** menu. First, select the grid data type you want to rename from the **Data Type** menu. Then, select the grid you want to rename by clicking on it in the list of current grids. The selected grid is highlighted after you select it. After you select a grid you can press the **Rename...** button on the right side of the window. A new window will open where you can provide the new name (Figure 64). You can also change the description at the same time. If the new description will be long, you can use the button to the right of the description field to open an editor. When you are satisfied with the name and description, press the **Rename** button to finish the process of renaming the selected grid. You cannot press the **Rename** button if no name is specified. If you change your mind and do not want to rename the selected grid, press the **Cancel** button or the **X** button in the upper right of the window to return to the grid data manager.

The second way to rename is from the *Watershed Explorer*, on the “Components” tab. Select the grid you want to rename by clicking on it in the *Watershed Explorer*; it will become highlighted. Keep the mouse over the selected grid and click the left mouse button again (Figure 65). The highlighted name will change to editing mode. You can then move the cursor with the arrow keys on the keyboard or by clicking with the mouse. You can also use the mouse to select some or all of



the name. Change the name by typing with the keyboard. When you have finished changing the name, press the **Enter** key to finalize your choice. You can also finalize your choice by clicking elsewhere in the *Watershed Explorer*. If you change your mind while in editing mode and do not want to rename the selected grid, press the **Escape** key.

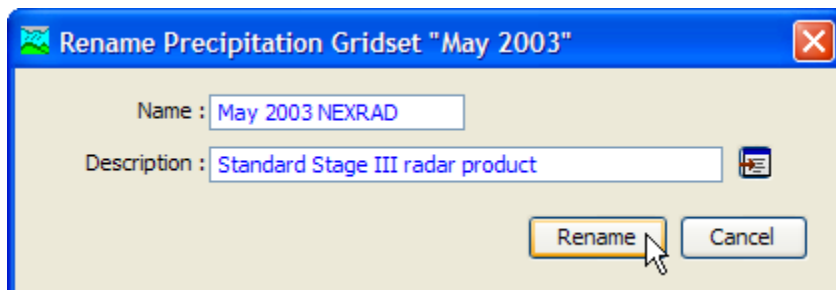

Figure 64. Renaming a precipitation gridset after pressing the **Rename...** button in the Grid Data Manager.

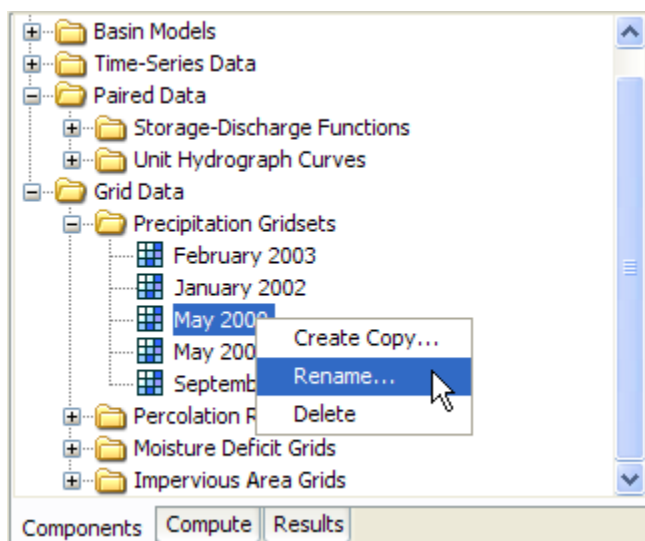

Figure 65. Renaming a precipitation gridset by selecting it in the Watershed Explorer and using the right-mouse menu.

## Deleting a Grid

There are two ways to delete a grid. Both methods for deleting a grid will remove it from the project and then automatically update all references to that grid. Once a grid has been deleted it cannot be retrieved or undeleted. Any references to the deleted grid will switch to using no grid, which is usually not a valid choice during a simulation. At a later time you will have to go to those components and manually select a different grid.

The first way to perform a deletion is to use the grid data manager, which you can access from the **Components** menu. First, select the grid data type you want to delete from the **Data Type** menu. Then,

select the grid you want to delete by clicking on it in the list of current grids. The selected grid is highlighted after you select it. After you select a grid you can press the **Delete** button on the right side of the

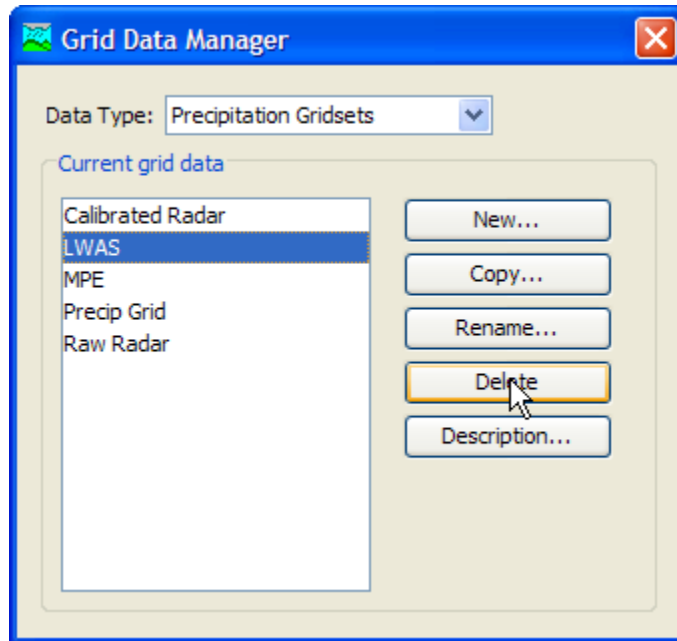

Figure 66. Preparing to delete a precipitation gridset from the Grid Data Manager.

window (Figure 66). A window will open where you must confirm that you want to delete the selected grid. Press the **OK** button to delete the grid. If you change your mind and do not want to delete the selected grid, press the **Cancel** button or the **X** button in the upper right to return to the grid data manager.

The second way to delete a grid is from the *Watershed Explorer*, on the “Components” tab. Select the grid you want to delete by clicking on it in the *Watershed Explorer*, it will become highlighted. Keep the mouse over the selected grid and click the right mouse button (Figure 67). A context menu is displayed that contains several choices including delete. Click the **Delete** menu option. A window will open where you must confirm that you want to delete the selected grid. Press the **OK** button to delete the grid. If you change your mind and do not want to delete the selected grid, press the **Cancel** button or the **X** button in the upper right to return to the *Watershed Explorer*.

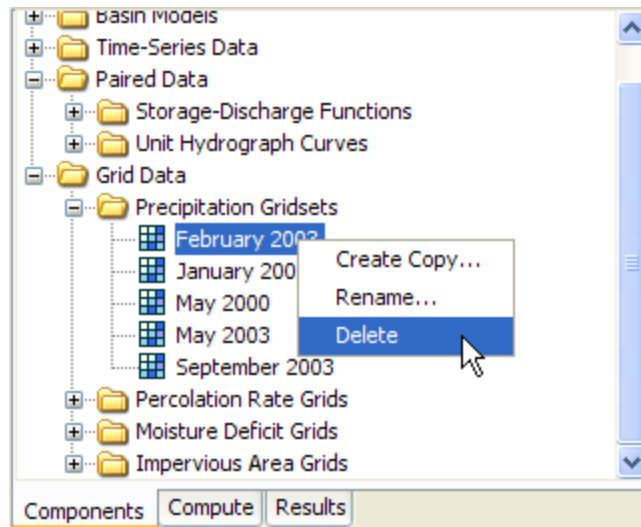

Figure 67. Preparing to delete a grid from the Watershed Explorer.

### Retrieval From a HEC-DSS File

Retrieving grid data from a DSS file requires that the data be loaded in a file. The file can be stored on the local computer or on a network server. It is not a good idea to store the file on removable media since the file must be available whenever the grid data is selected in the *Watershed Explorer*, and during computes. It is poor practice to store the data in the project DSS file used for storing simulation results. Data for each grid can be stored in a separate file or one file can contain data for several grids. However, all data for a gridset must be stored in the same DSS file and use appropriate pathname convention. It is best practice to store the DSS files holding gage data in the project directory, or a subdirectory of the project directory. Utilities are available from HEC for loading various formats of gridded data into a DSS file.

You must specify the filename to use for the grid data component (Figure 68). You may type the complete filename if you know it. To use a file browser to locate the file, press the **Open File Chooser** button to the right of the "DSS Filename" field. The browser allows you to find the desired file but it is limited to locating files with the DSS extension which is required for all Data Storage System files. Once you locate the desired file, click on it in the browser to select it and press the **Select** button. If you change your mind, press the **Cancel** button or the **X** button in the upper corner of the *Select HEC-DSS File* window to return to the *Component Editor*.

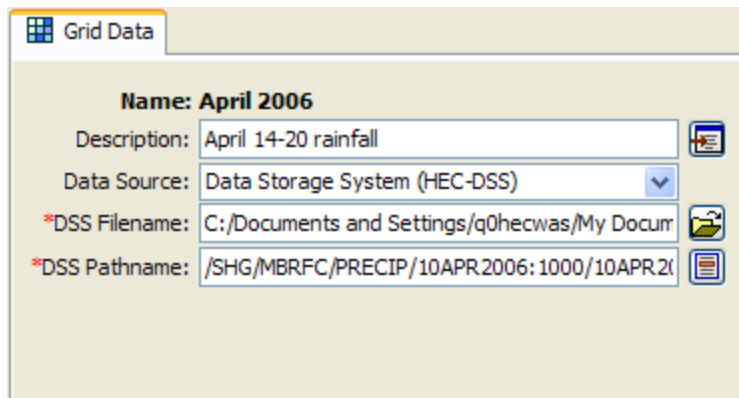

Figure 68. Component editor for a precipitation gridset. Grid data can only be stored in a HEC-DSS file.

You must also specify the pathname to retrieve from the selected DSS file (Figure 68). You may type the complete pathname if you know it. Each pathname contains six parts called the A-part, B-part, C-part, D-part, E-part, and F-part. The pathname parts are separated with a slash and may contain spaces. The complete pathname, including slashes and spaces, can total up to 256 uppercase characters. The following is an example of a pathname for a percolation parameter grid:

```
//SOLDIER CR WATERSHED/PERCOLATION///GIS ESTIMATE/
```

The convention for storing gridset data is different because a separate grid is required for each time interval. The different records will each have all the same pathname parts except for the D-part and E-part. The D-part indicates the starting time and the e-part the ending time of the individual record. Any of the record pathnames can be selected and the program will automatically retrieve the correct data depending on the time window during a compute. The following is an example of a temperature gridset:

```
//BRIDGER/TEMP/12JUL2003:1230/12JUL2003:1300/OBS/
```

If you do not know the full pathname of the record you wish you use, you can use the pathname browser to specify it. You must select a DSS file first before the browser is available. Press the **Select DSS Pathname** button to the right of the "DSS Pathname" field to open the browser. The browser initially shows all of the records in the specified DSS file, organized by pathname in the selection table. You can scroll through the list and select a record pathname by clicking on it. Press the **Select** button at the bottom of the browser to choose that record and return to the *Component Editor*. If you change your mind and do not want to select a record pathname, press the **Cancel** button or the **X** button in the upper right of the *Select Pathname From HEC-DSS File* window. You can reduce the number of record pathnames shown in

the selection table using the "Search by Parts" filters. A separate filter selection is shown for each of the six pathname parts. By selecting a choice for a filter, only pathnames that match that choice will be shown in the selection table. If you make choices in several filters, only pathnames that satisfy all of the choices will be shown in the selection table.

*Table 19. Internal DSS data type label for different types of grid data.*

<b>Grid</b>	<b>Label</b>	<b>Description</b>
Precipitation	PER-CUM	The precipitation depth occurring during the grid interval. The C-part should be "PRECIPITATION". The D-part and E-part, respectively, should give the start and end time for the cumulative value
Temperature	PER-AVER	The average temperature in degrees over during the grid interval. The C-part should be "TEMPERATURE". The D-part and E-part, respectively, should give the start and end time for the average value.
	INST-VAL	The temperature in degrees at a specific time. The C-part should be "TEMPERATURE". The time of the value should be specified in the D-part.
Solar Radiation	PER-AVER	The average solar radiation, measured in power per area, occurring during the grid interval. The C-part should be "SOLAR RADIATION". The D-part and E-part, respectively, should give the start and end time for the average value.
	INST-VAL	The solar radiation, measured in power per area, occurring at a specific time. The C-part should be "SOLAR RADIATION". The time of the value should be specified in the D-part.
Crop Coefficient	PER-AVER	The average crop coefficient, specified as a dimensionless decimal number, occurring during the grid interval. The C-part should be "CROP COEFFICIENT". The D-part and E-part, respectively, should give the start and end time for the average value.
	INST-VAL	The crop coefficient, specified as a dimensionless decimal number, occurring at a specific time. The C-part should be "CROP COEFFICIENT". The time of the value should be specified in the D-part.

Table 19. continued

<b>Grid</b>	<b>Label</b>	<b>Description</b>
Storage Capacity	INST-VAL	The storage capacity, measured as a depth, associated with a particular condition of the watershed. The C-part should be "STORAGE CAPACITY".
Percolation Rate	INST-VAL	The percolation rate, measured as a depth per time, associated with a particular condition of the watershed. The C-part should be "PERCOLATION".
Storage Coefficient	INST-VAL	The storage coefficient, measured in hours, associated with a particular condition of the watershed. The C-part should be "STORAGE COEFFICIENT".
Moisture Deficit	INST-VAL	The moisture deficit, measured as a depth, associated with a particular condition of the watershed. The C-part should be "MOISTURE DEFICIT".
Impervious Area	INST-VAL	The impervious area, measured as a percentage, associated with a particular condition of the watershed. The C-part should be "IMPERVIOUS AREA".
SCS Curve Number	INST-VAL	The curve number, as a dimensionless decimal number, associated with a particular condition of the watershed. The C-part should be "CURVE NUMBER".
Elevation	INST-VAL	The elevation, measured as a length or height, associated with a particular condition of the watershed. The C-part should be "ELEVATION".
Cold Content	INST-VAL	The cold content, measured as a depth, associated with a particular condition of the watershed. The C-part should be "COLD CONTENT".
Cold Content ATI	INST-VAL	The cold content antecedent temperature index, measured in degrees, associated with a particular condition of the watershed. The C-part should be "COLD CONTENT ATI".
Meltrate ATI	INST-VAL	The meltrate antecedent temperature index, measured in degrees, associated with a particular condition of the watershed. The C-part should be "MELTRATE ATI".

Table 19. continued

<b>Grid</b>	<b>Label</b>	<b>Description</b>
Liquid Water	INST-VAL	The amount of liquid water, measured as a depth, associated with a particular condition of the watershed. The C-part should be "LIQUID WATER".
Snow Water Equivalent	INST-VAL	The snow water equivalent, measured as a depth, associated with a particular condition of the watershed. The C-part should be "SWE".
Water Content	INST-VAL	The fraction of the water holding capacity of the soil that is saturated. The C-part should be "WATER CONTENT".
Water Potential	INST-VAL	The potential or suction in the soil expressed as a pressure during the grid interval. The C-part should be "WATER POTENTIAL".
Air Pressure	PER-AVER	The average air pressure occurring during the grid interval. The C-part should be "PRESSURE". The D-part and E-part, respectively, should give the start and end time for the average value.
	INST-VAL	The air pressure occurring at a specific time. The C-part should be "PRESSURE". The time of the value should be specified in the D-part.
Humidity	PER-AVER	The relative humidity, expressed as a percentage of saturation, occurring during the grid interval. The C-part should be "HUMIDITY". The D-part and E-part, respectively, should give the start and end time for the average value.
	INST-VAL	The relative humidity, expressed as a percentage of saturation, occurring at a specific time. The C-part should be "HUMIDITY". The time of the value should be specified in the D-part.
Windspeed	PER-AVER	The wind speed occurring during the grid interval. The C-part should be "WINDSPEED". The D-part and E-part, respectively, should give the start and end time for the average value.
	INST-VAL	The wind speed occurring at a specific time. The C-part should be "WINDSPEED". The time of the value should be specified in the D-part.

Table 19. continued

<b>Grid</b>	<b>Label</b>	<b>Description</b>
Energy	INST-VAL	The energy content of the snowpack. The C-part should be "ENERGY". The time of the value should be specified in the D-part.
Albedo	PER-AVER	The fraction of shortwave radiation that is reflected, expressed as a number between 0 and 1, during the grid interval. The C-part should be "ALBEDO".
Snow Depth	INST-VAL	The depth of the snow pack. The C-part should be "SNOW DEPTH". The time of the value should be specified in the D-part.
Flow Length	INST-VAL	The hillslope length for erosion. The C-part should be "LENGTH". The time of the value should be specified in the D-part.
Slope	INST-VAL	The hillslope slope for erosion. The C-part should be "SLOPE". The time of the value should be specified in the D-part.

Table 20. Internal DSS units label for different types of grid data.

<b>Grid</b>	<b>Label</b>	<b>Description</b>
Precipitation	MM	Millimeters
	IN	Inches
Temperature	DEG C	Degrees Celsius
	DEG F	Degrees Fahrenheit
Solar Radiation	WATT/M2	Watts per square meter
	LANG/MIN	Langleys per minute
Crop Coefficient	UNDEF	Dimensionless coefficient
Storage Capacity	MM	Millimeters
	IN	Inches
Percolation Rate	MM/HR	Millimeters per hour
	IN/HR	Inches per hour
Storage Coefficient	HR	Coefficient in hours
Moisture Deficit	MM	Millimeters
	IN	Inches



Table 20. Continued

<b>Grid</b>	<b>Label</b>	<b>Description</b>
Impervious Area	%	Percent of area
SCS Curve Number	UNDEF	Dimensionless parameter
Elevation	M	Meters
	FT	Feet
Cold Content	MM	Millimeters
	IN	Inches
Cold Content ATI	DEG C	Degrees Celsius
	DEG F	Degrees Fahrenheit
Meltrate ATI	DEGC-D	Degrees Celsius day
	DEGF-D	Degrees Fahrenheit day
Liquid Water Content	MM	Millimeters
	IN	Inches
Snow Water Equivalent	MM	Millimeters
	IN	Inches
Water Content	UNDEF	Fraction of saturation
Water Potential	MM	Millimeters
	IN	Inches
Air Pressure	KPA	Kilopascals
	INHG	Inches of mercury
Humidity	%	Percent relative humidity
Windspeed	KPH	Kilometers per hour
	MPH	Miles per hour
Energy	J/M2	Joules per square meter
	BTU/FT2	British thermal units per square foot
Albedo	UNDEF	Dimensionless coefficient
Snow Depth	M	Meters
	FT	Feet
Flow Length	M	Meters
	FT	Feet
Slope	M/M	Meters per meter
	FT/FT	Feet per foot

## **References**

Hydrologic Engineering Center. January 2003. HEC Data Storage System Visual Utility Engine: User's Manual. U.S. Army Corps of Engineers, Davis, CA.

## CHAPTER 6

# ***Watershed Physical Description***

This chapter describes how watershed information is entered into the program using a basin model. The basin model is used for describing the physical properties of the watershed and the topology of the stream network. It will contain the modeling components that describe canopy interception, surface storage, infiltration, surface runoff, baseflow, channel routing, and lakes. It may additionally contain components for representing engineered structures such as diversions, reservoirs, and pump stations. It will generally be the focus of attention in performing simulations and viewing results. By creating multiple representations of the same watershed, different development scenarios or management alternatives can be evaluated.

### ***Basin Models***

Basin models are one of the main components in a project. Their principle purpose is to convert atmospheric conditions into streamflow at specific locations in the watershed. Hydrologic elements are used to break the watershed into manageable pieces. They are connected together in a dendritic network to form a representation of the stream system. Background maps can be used to aid in placing the elements in a spatial context.

#### ***Creating a New Basin Model***

A new basin model is created using the *Basin Model Manager*. To access the manager, click on the **Components** menu and select the **Basin Model Manager** command. The manager will open and show all of the basin models currently in the project. The manager can remain open while you manage basin models or while you perform tasks elsewhere in the program. You can close the manager using the **X** button in the upper right corner. The buttons to the right of the model list can be used to manage existing models or create a new one. To create a new basin model, press the **New...** button. After you press the button a window (Figure 69) will open where you can name and describe the new basin model that will be created. A default name is provided for the new model; you can use the default or replace it with your own choice. A description can also be entered. If the description is long, you

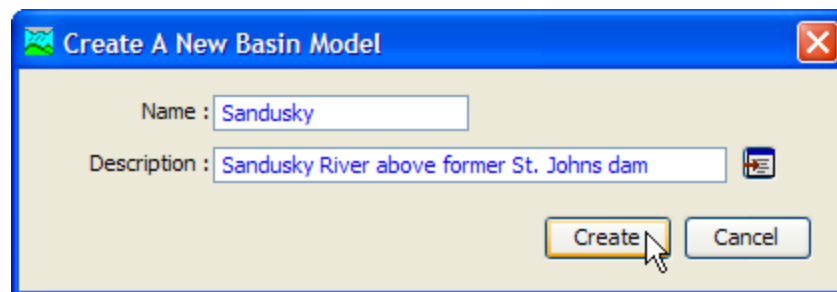

Figure 69. Creating a new basin model. This was accessed by opening the Basin Model Manager from the **Components** menu, and then pressing the **New...** button.

can press the button to the right of the description field to open an editor. The editor makes it easier to enter and edit long descriptions. When you are satisfied with the name and description, press the **Create** button to finish the process of creating the new basin model. You cannot press the **Create** button if no name is specified for the new model. If you change your mind and do not want to create a new basin model, press the **Cancel** button or the **X** button in the upper right to return to the *Basin Model Manager* window.

### **Copying a Basin Model**

There are two ways to copy a basin model. Both methods for copying a model create an exact duplicate with a different name. Once the copy has been made it is independent of the original and they do not interact.

The first way to create a copy is to use the *Basin Model Manager*, which is accessed from the **Components** menu. Select the basin model you wish to copy by clicking on it in the list of current basin models. The selected model is highlighted after you select it. After you select a model you can press the **Copy...** button on the right side of the window. A new *Copy Basin Model* window (Figure 70) will open where you can name and describe the copy that will be created. A default name is provided for the copy; you can use the default or replace it with your own choice. A description can also be entered; if it is long you can use the button to the right of the description field to open an editor. When you are satisfied with the name and description, press the **Copy** button to finish the process of copying the selected basin model. You cannot press the **Copy** button if no name is specified. If you change your mind and do not want to copy the selected basin model, press the **Cancel** button or the **X** button in the upper right to return to the *Basin Model Manager* window.

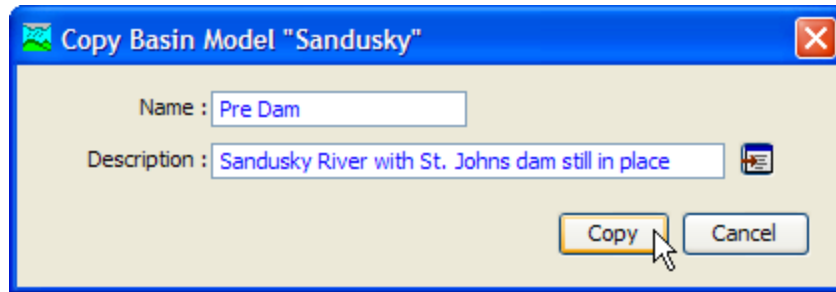

Figure 70. Creating a copy of a basin model.

The second way to copy is from the "Components" tab of the *Watershed Explorer*. Move the mouse over the basin model you wish to copy, then press the right mouse button (Figure 71). A context menu is displayed that contains several choices including copy. Click the **Create Copy...** command. A new *Copy Basin Model* window will open where you can name and describe the copy that will be created. A default name is provided for the copy; you can use the default or replace it with your own choice. A description can also be entered; if it is long you can use the button to the right of the description field to open an editor. When you are satisfied with the name and description, press the **Copy** button to finish the process of copying the selected basin model. You cannot press the **Copy** button if no name is specified. If you change your mind and do not want to copy the selected basin model, press the **Cancel** button or the **X** button in the upper right of the *Copy Basin Model* window to return to the *Watershed Explorer*.

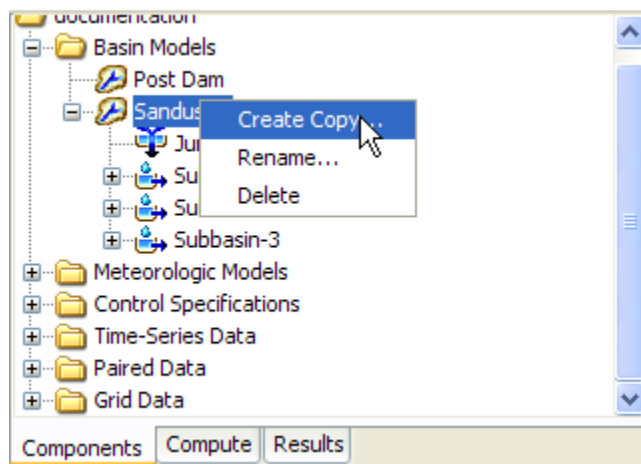

Figure 71. Copying a basin model from the Watershed Explorer. The *Copy Basin Model* window will appear after the **Create Copy...** menu command is selected.

## Renaming a Basin Model

There are two ways to rename a basin model. Both methods for renaming a model change its name and then all references to the old model name are automatically updated to the new name.

The first way to perform a rename is to use the *Basin Model Manager*, which you can access from the **Components** menu. Select the basin model you wish to rename by clicking on it in the list of current basin models. The selected model is highlighted after you select it. After you select a model you can press the **Rename...** button on the right side of the window. A new *Rename Basin Model* window (Figure 72) will open where you can provide the new name. If you wish you can also change the description at the same time. If the new description will be long, you can use the button to the right of the description field to open an editor. When you are satisfied with the name and description, press the **Rename** button to finish the process of renaming the selected basin model. You cannot press the **Rename** button if no name is specified. If you change your mind and do not want to rename the selected basin model, press the **Cancel** button or the **X** button in the upper right of the *Rename Basin Model* window to return to the *Basin Model Manager* window.

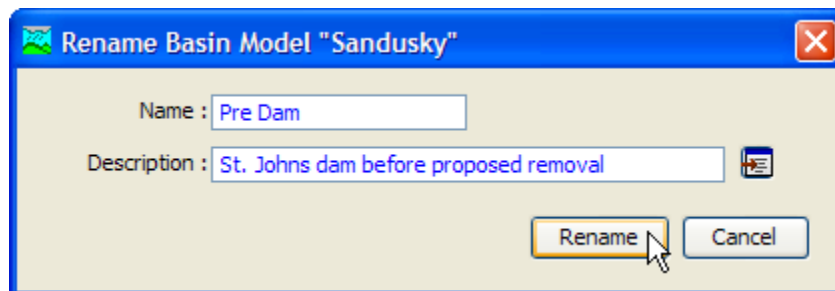

Figure 72. Renaming a basin model. This was accessed from the *Basin Model Manager*.

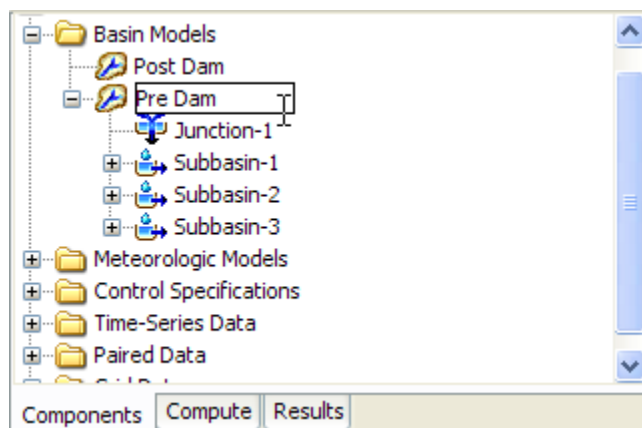

Figure 73. Renaming a basin model in the *Watershed Explorer*.

The second way to rename is from the "Components" tab of the *Watershed Explorer*. Select the basin model you wish to rename by clicking on it in the *Watershed Explorer*; it will become highlighted. Keep the mouse over the selected model and click the left mouse button again. The highlighted name will change to editing mode as shown in Figure 73. You can then move the cursor with the arrow keys on the keyboard or by clicking with the mouse. You can also use the mouse to select some or all of the name. Change the name by typing with the keyboard. When you have finished changing the name, press the **Enter** key to finalize your choice. You can also finalize your choice by clicking elsewhere on the "Components" tab. If you change your mind while in editing mode and do not want to rename the selected basin model, press the **Escape** key.

### ***Deleting a Basin Model***

There are two ways to delete a basin model. Both methods for deleting a model remove it from the project and then automatically update all references to that model. Once a model has been deleted it cannot be retrieved or undeleted. Any references to the deleted model will switch to using no basin model, which is usually not a valid choice during a simulation. At a later time you will have to go to those components and manually select a different basin model.

The first way to perform a deletion is to use the *Basin Model Manager*, which you can access from the **Components** menu. Select the basin model you wish to delete by clicking on it in the list of current basin models. The selected model is highlighted after you select it. After you select a model you can press the **Delete** button on the right side of the window. A window will open where you must confirm that you wish to delete the selected model as shown in Figure 74. Press the **OK** button to delete the model. If you change your mind and do not want to delete the selected basin model, press the **Cancel** button or the **X** button in the upper right to return to the *Basin Model Manager* window.

The second way to delete is from the "Components" tab of the *Watershed Explorer*. Select the basin model you wish to delete by clicking on it in the *Watershed Explorer*; it will become highlighted. Keep the mouse over the selected model and click the right mouse button (Figure 75). A context menu is displayed that contains several choices including delete. Click the **Delete** command. A window will open where you must confirm that you wish to delete the selected model. Press the **OK** button to delete the model. If you change your mind and do not want to delete the selected basin model, press the **Cancel** button or the **X** button in the upper right to return to the *Watershed Explorer*.

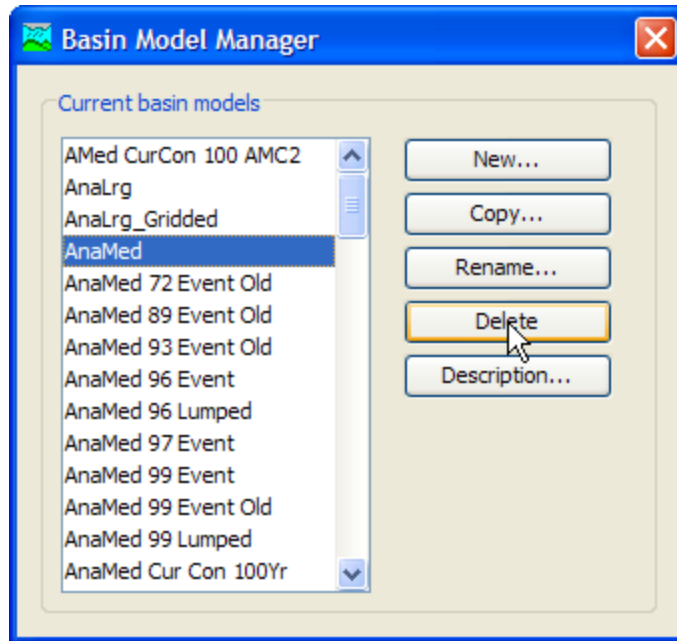

Figure 74. Preparing to delete a basin model from the Basin Model Manager. A confirmation will be required after pressing the **Delete** button.

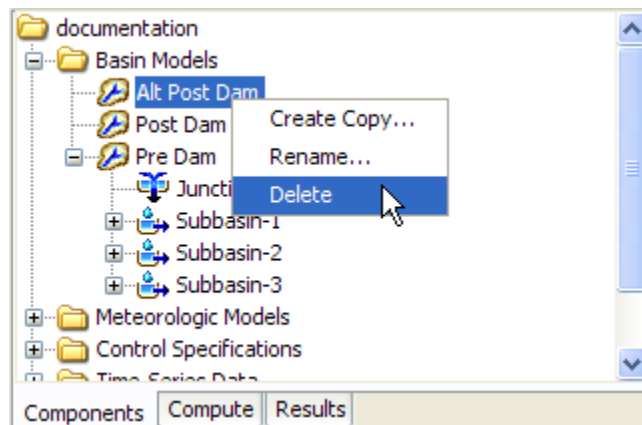

Figure 75. Deleting a basin model in the Watershed Explorer.

### Importing a Basin Model

You can import a basin model from another project into the current project. The model must have been created previously and stored on your computer or an accessible network location. Click the **Tools** menu and select the **File** ⇒ **Import** ⇒ **Basin Model...** command. A file browser will open that you can use to find the model you wish to import. The browser will only allow you to select basin model files which end with the **BASIN** extension. When you click on a basin model file in the browser, the description of the model is shown on the right side of the browser. Once you have located and selected the desired basin model, press the **Select** button. If you change your



mind, you can press the **Cancel** button or the **X** button in the upper right to return to the main program window without importing a model. After you make your selection, the basin model will be checked for dependent data such as time-series gages. The user is given the opportunity to also import any required data. The program automatically copies the selected file and any additional data into the project folder and adds the various components to the project.

## Basin Model Properties

There are a number of properties for basin models that are selected on the *Component Editor* (Figure 76). These properties control configuration settings for the basin model itself or for all hydrologic elements within the basin model. Access the *Component Editor* from the *Watershed Explorer* on the "Components" tab by clicking on a basin model icon.

Figure 76. Basin model component editor showing option properties for gridded subbasins and flow computations.

## Gridded Subbasins

Subbasins that use the ModClark gridded transform method are considered gridded subbasins. Loss rate and surface transform calculations will be carried out on a grid cell basis. Properties of the grid cells are specified in a special grid cell file. The file specifies which grid cells are in each subbasin, along with the properties of each cell including location, area within the subbasin, and distance to the subbasin outlet. Regardless of which transform method is selected, if gridded meteorological methods will be used, the grid cell file is also required. One file is used for all subbasins in the basin model and its format is described in Appendix B. If you wish to use gridded subbasins, you must prepare the file external to the program and specify it as part of the basin model parameter data. Specify the

complete filename of the grid cell file in the *Component Editor* for the basin model (Figure 76). Access the *Component Editor* from the *Watershed Explorer* on the "Components" tab by clicking on a basin model icon. You can use the file browser button to the right of the entry field to aid in finding the file.

### **Local Flow**

Local flow can be computed at junctions. Local flow is defined as the sum of all subbasin and source outflows entering a junction. The subbasin and source elements must be connected directly to the junction. Any subbasin or source outflow that moves through a routing element is no longer considered local flow. When local flow is disabled, a junction element computes outflow as the sum of all inflow from any type of element. No local flow is computed. When local flow is enabled, a junction continues to compute outflow as the sum of all inflow. However, in addition to computing outflow, it additionally computes local flow (sum of subbasin and source elements). Enabling or disabling local flow is done in the *Component Editor* for the basin model (Figure 76). Access the *Component Editor* from the *Watershed Explorer* on the "Components" tab by clicking on a basin model icon.

### **Flow Ratio**

Flow ratios can be used to increase or decrease the computed flow by a fixed ratio; they can only be applied to subbasin and source elements. Once the flow ratios are turned on, each subbasin and source can have a separate ratio, or no ratio. It is not necessary to enter a ratio for every element in order to have a ratio at one element. The ratio 1.0 is used if no ratio is specified. The calculations for computing outflow proceed normally according to the method choices and parameter data for each element. At the conclusion of normal processing, the flow ratio is applied to produce the final outflow.

Flow ratios are enabled or disabled in the *Component Editor* for the basin model (Figure 76). After disabling the flow ratios, any ratios specified for subbasin and source elements in the basin model are removed and cannot be retrieved again or undeleted. The actual flow ratio is specified in the *Component Editor* for the element on the "Options" tab. Access the editor from the *Watershed Explorer* on the "Components" tab by clicking on the element icon. The last tab in the *Component Editor* is the "Options" tab. The flow ratio field is disabled when flow ratios are disabled in the basin model. The field becomes enabled when flow ratios are enabled in the basin model. The flow ratio field is never enabled for elements other than subbasins and sources.

## **Missing Flow**

Missing inflow data for an element can be set to zero. Under some conditions it may be possible for source or subbasin elements to produce outflow with missing values. Downstream routing elements generally cannot process missing data. When missing flow data is not replaced, any element that encounters missing inflow data will halt a simulation with an error message. When missing flow data is replaced, the missing inflow data is set to zero and a message is generated that indicates how many values were missing. Processing in the routing element proceeds normally after any missing inflow data is set to zero. Setting the action to take with missing inflow data is done on the *Component Editor* for the basin model (Figure 76).

## **Unit System**

Each basin model must be in either United States customary units (sometimes called English units) or in system international units (also called metric units). All parameter data in a basin model must be in the same unit system. If you change the unit system, all data will be automatically converted to the new unit system. All time-series data, paired data, and gridded data referenced in a basin model will be in its own unit system. If necessary these referenced data are automatically converted to the unit system of the basin model during a simulation.

Select the unit system using the *Component Editor* for the basin model (Figure 76). Access the *Component Editor* by clicking the basin model icon on the "Components" tab of the *Watershed Explorer*. If you change the unit system, all data is automatically converted to the new selection.

## **Sediment**

The movement of sediment in the watershed can be included as part of the hydrology of the basin model. When the sediment is disabled, no sediment processing will take place in the basin model. When the sediment is enabled, appropriate sediment simulation components are added to elements in the basin model. Subbasin elements include surface erosion and wash-off. Reach elements include erosion, deposition, and sediment transport. Reservoir elements include sediment settling and sediment transport. Source, junction, diversion, and sink elements pass sediment through the channel network.

## **Water Quality**

Nutrient water quality (nitrogen and phosphorus) can be included as part of the hydrology of the basin model. When the water quality is disabled, no water quality processing will take place in the basin

model. When the water quality is enabled, appropriate water quality simulation components are added to elements in the basin model. Subbasin and source elements include time-series of boundary conditions. Reach and reservoir elements include fate and transport of the nutrient constituents. Junction, diversion, and sink elements pass constituents through the channel network.

## ***Basin Model Map***

The *Basin Model Map* is the primary method for visualizing the hydrologic elements that will be added to the basin model to represent the watershed. Background maps can be added to display almost any type of mapping data. It is often helpful to configure the background maps before beginning the process of creating hydrologic elements and the flow network.

### ***Background Maps***

Background maps provide a spatial context for the hydrologic elements composing a basin model. The maps are not actually used in the compute process, but they can be very helpful in showing the spatial relationship between elements. They are commonly used for showing the boundaries of a watershed or the location of streams. They can also be useful for showing supplemental information such as the location of levees. The use of background maps is always optional.

Background maps are added and removed using the *Background Maps* window (Figure 77). Access the window by clicking the **View** menu and selecting the **Background Maps** command. The menu command is only available if the *Basin Model Map* window is currently open. Any changes made to the current background maps or their draw order take affect immediately as soon as they are made.

Add a map to the list of current background maps by pressing the **Add...** button. A file browser opens for you to select the map file you wish to add. Six different map file formats can be used. The HMS map file and geo-reference image file formats are described in Appendix D. File formats for the other map types are defined by their creators (Autodesk 2005, ESRI 1997, USGS 1999). Select the type of map file you wish to add using the "Files of type" selection list at the bottom of the file browser.

Locate the map file you wish to add and select it. Press the **Select** button to add the map to the list of current background maps. If you change your mind and do not want to add a map, press the **Cancel** button or the **X** button in the upper right of the *Select* window. The program does not include any coordinate transformation tools so you

must independently make certain that all maps you wish to use are in the same coordinate system.

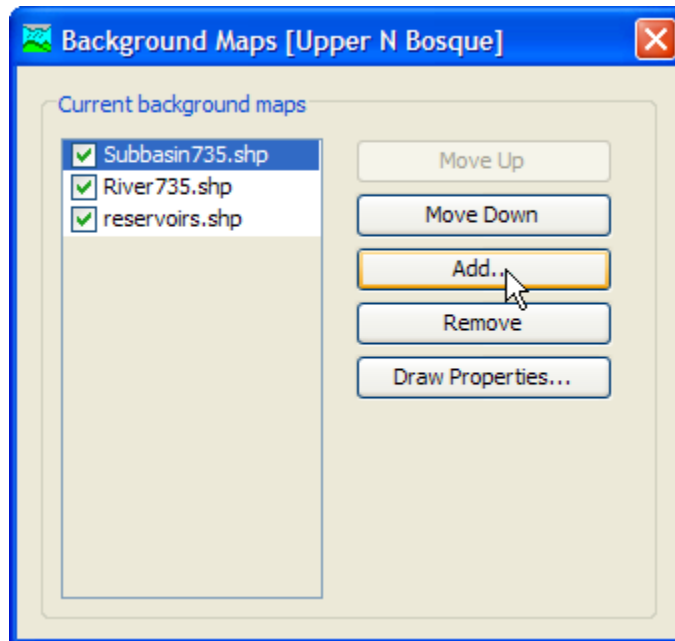

Figure 77. Background maps can be added to provide a spatial context for the basin model elements. Maps can be moved up or down in the drawing order.

The current background maps are drawn in a specified order so that you can control overlapping and other drawing issues. The draw order is based on the order they are shown in the *Background Maps* window. The map at the bottom of the list is drawn first. After it is drawn, the map shown above it in the list is drawn second. The map shown at the top of the list is drawn last. The hydrologic elements are drawn after all of the maps have been drawn. You may temporarily turn drawing for a map "on" or "off" using the check box in the map list.

The draw order of the maps can be changed once all the desired background maps are shown in the list of current maps. To change the order of a map you must first select it in the list of current maps. Place the mouse over the desired map and click the left mouse button; the map name is highlighted to show that it is selected. Press the **Move Up** button to move the map up in the draw order so that other maps are drawn first. Press the **Move Down** button to move the map down in the draw order so that other maps are drawn after it. Each time you press the **Move Up** or **Move Down** button the map is moved one position up or down. You can press the buttons more than once to get the map to the desired position in the drawing order.

A background map can be removed from the display. Place the mouse over the map you wish to remove and select it by clicking the left

mouse button; the map name is highlighted to show that it is selected. Press the **Remove** button. The background map is not deleted when it is removed from the list of current background maps. The files that contain the actual background map data cannot be deleted from the program; they must be deleted manually.

The drawing properties of a background map using the Shape File format can be controlled. The Draw Properties button will be enabled whenever a map is selected that uses the Shape File format. Pressing the button will open an editor that allows control of drawing properties including colors, line style and width, shading, transparency, and other properties. Changes may be previewed before they become final. At this time, draw properties cannot be controlled for other file formats.

### ***Maximum Extents***

The maximum extents are designed to limit the area shown in the *Basin Model Map* window to a reasonable view. This is especially helpful if background maps are used which cover a very large region; much larger than the watershed. Four different methods are available for specifying the maximum extents. Setting the maximum extents is done from the *Maximum Extents* window (Figure 78) accessed by selecting the **View ⇒ Maximum Extents** command.

The `Manual` option will set the extents to a region specified by the user. When this option is selected, the "Manual view extents" box will be available. The "Minimum Northing" corresponds to the South edge and the "Maximum Northing" corresponds to the North edge of the extents. The "Minimum Easting" corresponds to the West edge and the "Maximum Easting" corresponds to the East edge of the extents. You may enter the appropriate values in the coordinate system of the current background maps. The northing and easting values can automatically be filled in from the current view in the basin map display by pressing the **Set** button.

The `Union of All Elements` option will set the extents to the combined extents of all the hydrologic elements in the basin model. As elements are added and removed, the maximum extents will automatically be updated. The "Element Buffer" can be used to make sure there is some space around the elements. When the extents are computed, the buffer is computed as the percentage of the width and height of the elements themselves.

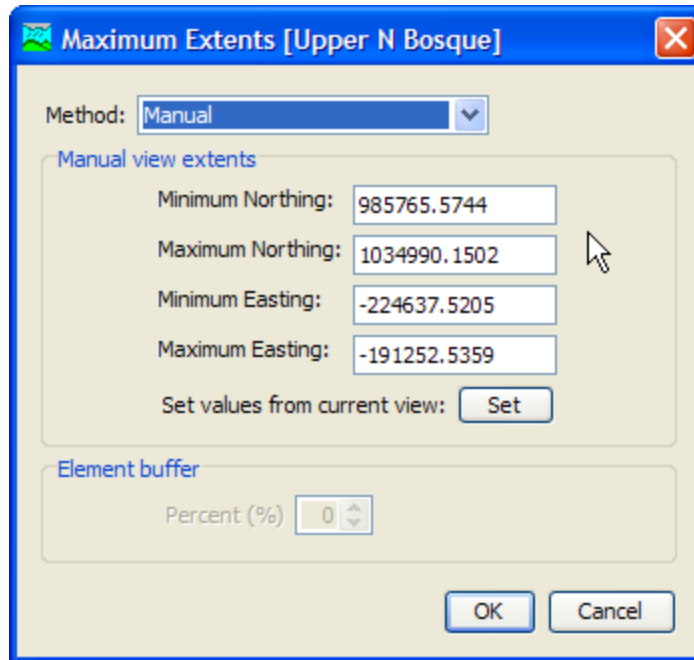

Figure 78. The maximum extents are used to control the view size of the basin model, and facilitate use of maps larger than the watershed of interest.

The `Union of All Maps` option will set the extents to the combined extents of all background maps. As maps are added and removed, the maximum extents will automatically be updated.

The `Union of All Maps` and `Elements` options will set the extents to the combined extents of all background maps and hydrologic elements in the basin model. As elements are added and removed, or as background maps are added and removed, the extents will automatically be updated. The "Element Buffer" will be applied to the elements as part of computing the extents.

### **Background Gridlines**

Background gridlines are useful for helping to measure approximate distance in the *Basin Model Map* window. They are not drawn at a specific scale; the relative scale changes depending on the current view. There is only one way to turn the grid lines on and off.

Turn the gridlines on and off using the **View** menu. Click on the **View** menu and select the **Draw Gridlines** command. A check is shown next to the menu command to indicate that the gridlines are turned on. The lines are drawn first in the map using a light gray color, then all other maps and the hydrologic elements are drawn. You can turn off the gridlines by clicking on the same menu command again.

## **Adjusting the View and Zooming**

Several tools and commands are provided to zoom in, zoom out, and move around the *Basin Model Map* window. Several of the tools are on the toolbar. All of the commands can be found on the **View** menu.

There are two ways to zoom in on the *Basin Model Map* window. The first way is using the *Zoom In Tool* to zoom in on a specific region in the *Basin Model Map* window. Select the tool from the toolbar and then move the mouse over the *Basin Model Map* window; the mouse will change to the zoom in cursor. Place the mouse on one corner of the area you want to magnify, then hold the left mouse button and drag the mouse to draw a box around the region. When you release the left mouse button, the region you selected will be redrawn to fill the *Basin Model Map* window. You can zoom in as many times as you wish as long as the *Zoom In Tool* is selected. The second way is using the **Zoom In** command on the **View** menu. Every time you select the **Zoom In** command, the center of the *Basin Model Map* window will zoom in by a predefined amount. The **Zoom In** command is only accessible when the *Basin Model Map* window is open.

There are two ways to zoom out in the *Basin Model Map* window. The first way is using the *Zoom Out Tool* to zoom out from a specific point in the *Basin Model Map* window. Select the tool from the toolbar and then move the mouse over the *Basin Model Map* window; the mouse will change to the zoom out cursor. Place the mouse at the point where you wish to zoom out and press the left mouse button. The *Basin Model Map* window redraws immediately after zooming out a predefined amount, centered on the point where you clicked. The second way is using the **Zoom Out** command on the **View** menu. Every time you select the **Zoom Out** command, the center of the *Basin Model Map* window will zoom out by a predefined amount. The **Zoom Out** command is only accessible when the *Basin Model Map* window is open.

It may not be possible to view the entire basin model simultaneously in the *Basin Model Map* window if the zoom has been used. Scroll bars are automatically added to the *Basin Model Map* window when it is not possible to show the entire basin model. You can use the scroll bars regardless of which tool is selected on the toolbar. As you move the scroll bars, the view shown in the *Basin Model Map* window will change but it will not redraw until you stop scrolling. Redrawing the view can be time intensive when background maps have been added. Only one scroll bar can be used at a time, but the *Pan Tool* allows complete freedom to change the view in any direction. Select the tool from the toolbar and move the mouse over the *Basin Model Map* window; the mouse changes to the move cursor. Place the mouse



where you wish to begin and hold the left mouse button. Drag the mouse in any direction to change the view. The new view will be redrawn when you release the mouse button.

It can be very difficult to find the selected element or elements in a basin model with many hydrologic elements. A special tool has been created to zoom to the current element selection. Begin by creating an element selection. You can click on an element in the *Watershed Explorer*, or use the **Edit** ⇒ **Select Special** command to create a current selection. You can zoom to the selection by clicking the **View** menu and selecting the **Zoom To Selected** command. The *Basin Model Map* window will automatically zoom to an appropriate scale for the current element selection and center the view on the selection.

After zooming in and moving around the basin model, you may want to quickly return to viewing the entire model. You can immediately zoom to the maximum extents. Click the **View** menu and select the **Zoom To Maximum Extents** command. The *Basin Model Map* window will automatically zoom out to the coordinates specified as the maximum extents and redraw.

### ***Drawing Elements and Labels***

Hydrologic elements can be drawn as icons, as map objects, or as map objects and icons. Drawing with icons and map objects is controlled separately. There is only one way to control each property. Additionally, elements can be labeled when they are drawn.

The basic method for drawing elements is with icons. Each element type has a unique icon for quick visual identification. Reach elements are an exception since they are drawn as a line from the upstream end of the reach to the downstream end. Turn the icons on and off using the **View** menu. Click on the **View** menu and select the **Draw Element Icons** command. A check is shown next to the menu command to indicate that the icons are turned on. You can turn off the icons by clicking on the same menu command again.

The advanced method for drawing elements is with map objects. Each subbasin element can be drawn with a polygon representing the outline of the subbasin. Each reservoir element can also be drawn with a polygon which usually represents the outline of the maximum extent of the pool. Each reach element can be drawn with a polyline representing the exact turns of the stream. Turn the map objects on and off using the **View** menu. Click on the **View** menu and select the **Draw Map Objects** command. A check is shown next to the menu command to indicate that the map objects are turned on. You can turn off the map objects by clicking on the same menu command again.

The geometric data necessary to provide the map objects drawing for elements is stored in external files that use the ESRI Shape File format. Three separate files are used for subbasin, reservoir, and reach geometric data. Currently the files must be created externally to the program. Additionally, the files must be stored in the same directory as the basin model, which is usually stored in the project directory. The files use a strict naming convention as illustrated below:

Basin Model "Baseline"	Baseline.basin
Subbasin polygon geometry	Baseline_Subbasin.shp
Reservoir polygon geometry	Baseline_Reservoir.shp
Reach polygon geometry	Baseline_Reach.shp

The ESRI Shape File format is actually composed of a family of individual files that together contain the geometric, field properties, and meta data. Each file in the family has the same filename but a different extension. The minimum set of files necessary to define the subbasin, reservoir, or reach geometric data include the SHP file, SHX file, and DBF file. It is strongly recommended that the projection file PRJ also be included.

Using element map objects is optional. When map objects are used, it is not necessary to have subbasin, reservoir, and reach geometric data. It is permissible to use map objects for one, two, or all three types of elements. Additionally, it is not necessary to have map objects for every single subbasin, reservoir, or reach in the basin model. Map objects will be drawn for the elements for which it is available.

Geometric data in the ESRI Shape Files is matched to the elements using the element name. The element name is specified when creating the element in the *Basin Model Map* window. The geometric data must have the same element name. The element name of the geometric data is specified using the "Name" field property in the DBF file. The example project "river bend" includes map objects for the subbasin elements. The example project can be installed from the **Help** menu; select the **Install Sample Projects** menu command.

Element labels can be drawn with element icons or element map objects. Currently the only option for the label is the name of the element. Turn the element labels on and off using the **View** menu. Click on the **View** menu and select the **Draw Element Labels** command to choose how to draw the labels. A check is shown next to the selected option. To change the selected option, use the mouse to click on a different choice.

## ***Displaying Flow Directions***

Each reach element in the network only allows flow to move in one direction; from upstream to downstream. If a reach is connected to its upstream and downstream elements in the wrong direction, then the network may not be a good representation of the physical watershed. You can verify the flow directions by displaying direction arrows. When the direction arrows are turned on, arrow heads are added to reach elements to show the flow direction. There is only one way to turn the flow direction arrows on and off.

Turn the flow direction arrows on and off using the **View** menu. Click on the **View** menu and select the **Draw Flow Directions** command. A check is shown next to the menu command to indicate that the arrows are turned on. You can turn off the direction arrows by clicking on the same menu command again.

## ***Hydrologic Elements***

Hydrologic elements are the basic building blocks of a basin model. An element represents a physical process such as a watershed catchment, stream reach, or confluence. Each element represents part of the total response of the watershed to atmospheric forcing. Seven different element types have been included in the program: subbasin, reach, reservoir, junction, diversion, source, and sink.

An element uses one or more mathematical models to describe a physical process occurring in the watershed. Sometimes the model is only a good approximation of the original physical process over a limited range of environmental conditions. Data availability and the required parameters of a model can also determine fitness. To make the program suitable for many different conditions, most elements have more than one model or method for approximating the physical process. For example, there are seven different methods for specifying overland flow for a subbasin.

### ***Creating a New Element***

New hydrologic elements are created directly in the *Basin Model Map* window. Begin the process of creating a new element by opening the basin model into which you wish to add a new element. Select a basin model in the *Watershed Explorer* to open it. Separate tools are provided in the toolbar for each of the seven different kinds of element. Select the tool corresponding to the type of element you wish to create: subbasin, reach, reservoir, junction, source, diversion, or sink. After selecting the appropriate tool, move the mouse over the *Basin Model Map* window; the mouse cursor changes to cross hairs. Move the mouse until the cross hairs are over the location where you wish to

create the element. Click the left mouse button. A window will open where you can name and describe the new hydrologic element that will be created, as shown in Figure 79. A default name is provided for the new element; you can use the default or replace it with your own choice. A description can also be entered. If the description is long, you can press the button to the right of the description field to open an editor. The editor makes it easier to enter and edit long descriptions. When you are satisfied with the name and description, press the **Create** button to finish the process of creating the new hydrologic element. You cannot press the **Create** button if no name is specified for the new element. If you change your mind and do not want to create a new hydrologic element, press the **Cancel** button or the **X** button in the upper right to return to the *Basin Model Map* window. After you finish creating one element, the element creation tool is still selected and you can create additional new elements of the same type.

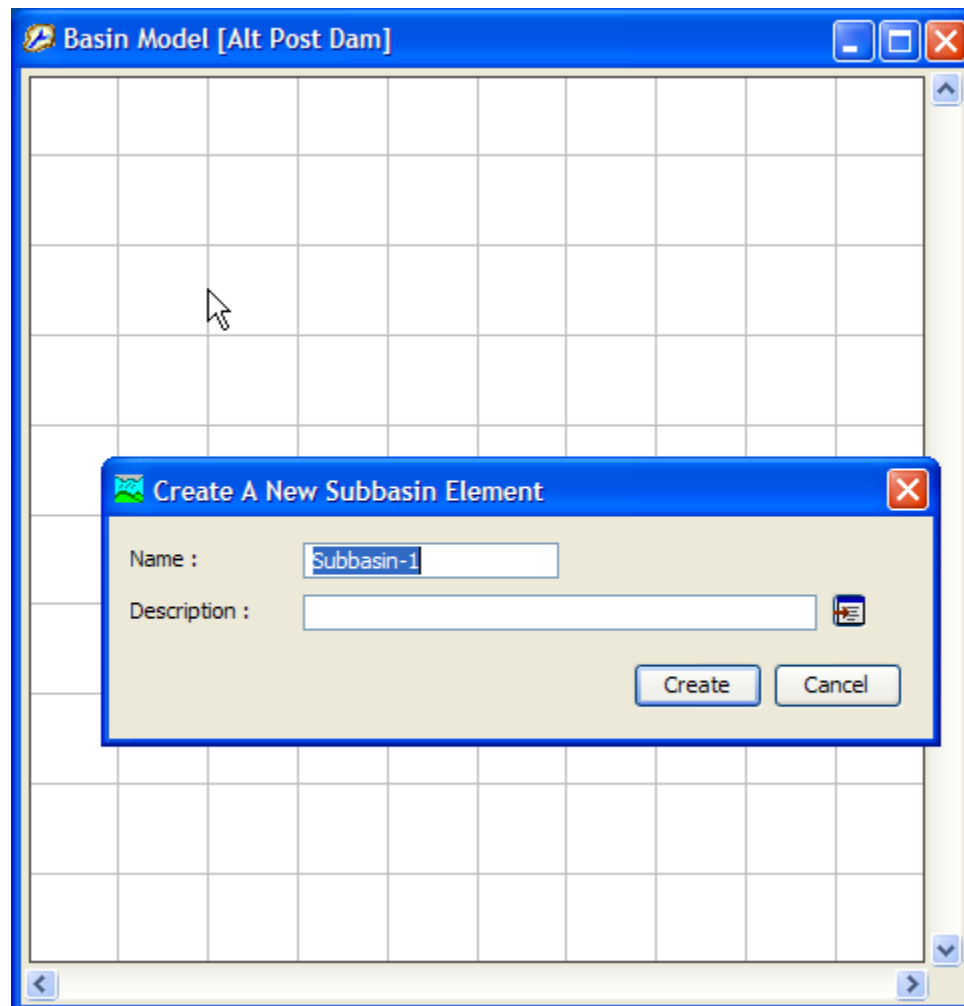

Figure 79. Creating a subbasin in a new basin model. The subbasin tool was selected on the toolbar. The cursor changed from cross hairs back to a pointer when the left mouse button was pressed

*at the desired location for the new element. It is a good idea to customize the default name.*

Most of the elements are created by clicking the mouse button over the location where you want to create the element. However, two mouse clicks are required when creating a reach element. To create a reach, begin by selecting the correct tool from the toolbar. Next click once over the location you want to be the upstream end of the reach. Then as you move the mouse you will see a line connecting the mouse to the upstream end of the reach. Move the mouse to the location you want to be the downstream end of the reach and click. You will finish the process of creating a reach by selecting a name and entering the optional description.

### ***Copying an Element***

Hydrologic elements can be copied to the clipboard from one basin model and then exact duplicates can be pasted in either the same or a different basin model. Begin by opening the basin model that contains the element or elements you wish to copy. Select the hydrologic element you wish to copy by clicking on it with the arrow tool. You may also select more than one element in the map. The selected element or elements become highlighted after the selection. After you make a selection, place the mouse over a selected element and press the right mouse button as shown in Figure 80. A context menu is displayed that contains several choices including copy. Click the **Copy Element** command. If more than one element is selected, select the **Copy Elements** command. You can now paste the selection into the same or a different basin model. The copy command is only available if there is at least one element selected.

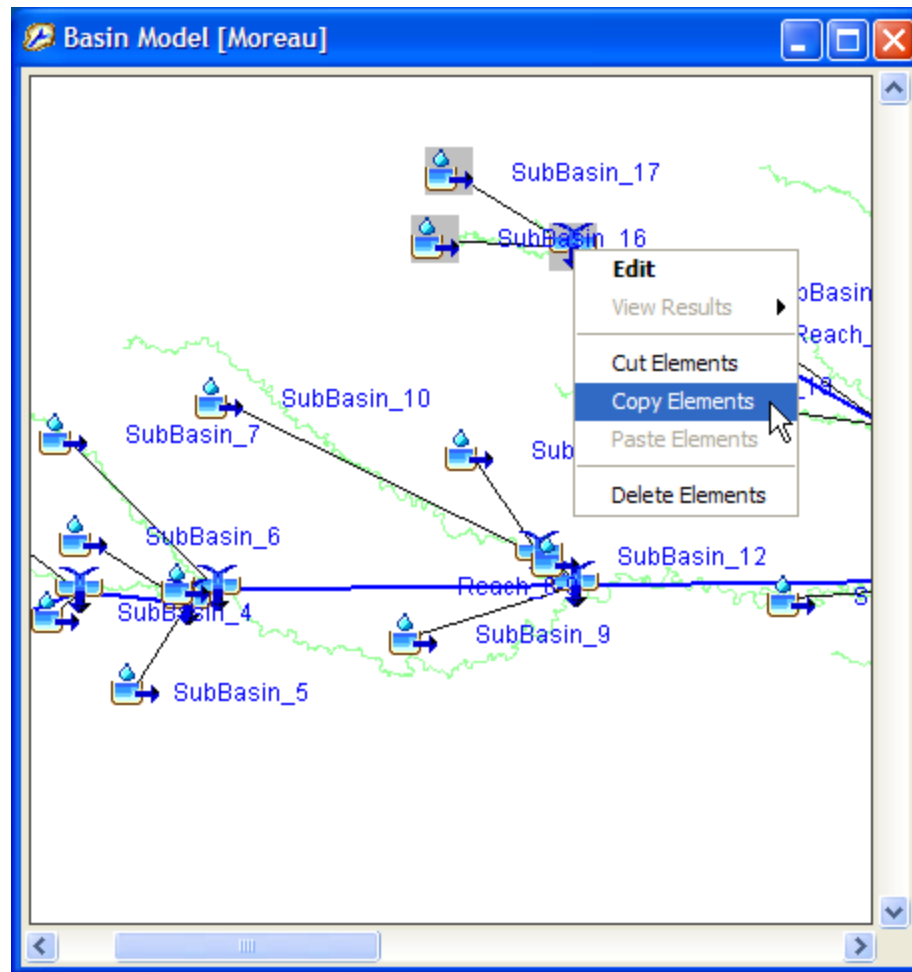

Figure 80. Copying a group of selected elements from the basin map to the clipboard; the elements will remain in the basin model. If the elements were cut, they would be on the clipboard but removed from the basin model.

### Pasting an Element

An element in the clipboard can be pasted into a basin model. Pasting an element does not remove it from the clipboard so you can paste the same selection into multiple basin models. Begin by opening the basin model into which you wish to paste elements from the clipboard. Select the arrow tool and move the mouse to the location where you wish to paste the element. If there are multiple elements on the clipboard then you should place the mouse where you want the center of the element grouping to be located. Press the right mouse button as shown in Figure 81. A context menu is displayed that contains several choices including paste. Click the **Paste Element** command. The paste command is only available if there is at least one element on the clipboard.

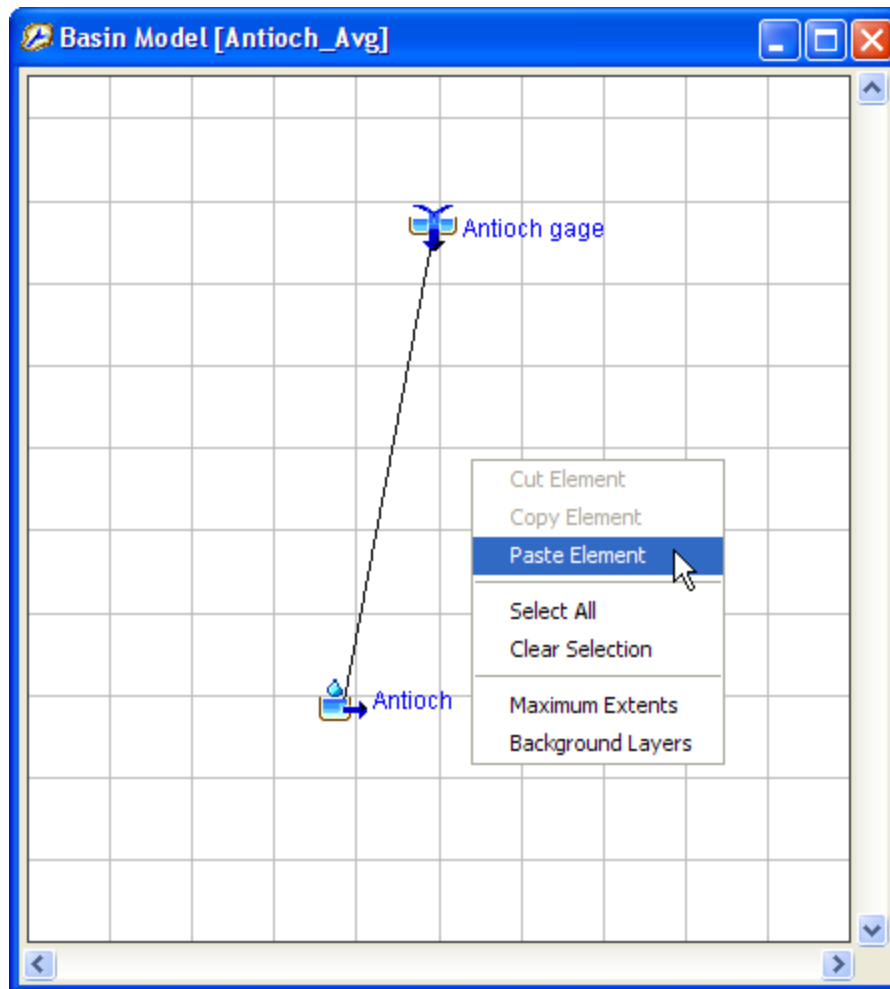

Figure 81. Pasting an element selection into the basin map. The mouse was placed where the pasted element should be added to the basin map and the right mouse button was pressed. Now the Paste Element command can be selected.

### **Cutting an Element**

An element can be cut from a basin model and removed to the clipboard. Cutting an element places an exact but independent copy of the element on the clipboard and then deletes it from the basin model. Once an element is in the clipboard it can be pasted into the same basin model from which it was copied or it can be pasted into a different model. Begin by opening the basin model from which you wish to cut an element. Select the hydrologic element you wish to cut by clicking on it with the arrow tool. You may also select more than one element in the map. The selected element or elements become highlighted after the selection. After you make a selection, place the mouse over a selected element and press the right mouse button. A

context menu is displayed that contains several choices including cut. Click the **Cut Element** command. You can now paste the selection into the same or a different basin model. The cut command is only available if there is at least one element selected.

### Renaming an Element

Rename a hydrologic element using the "Components" tab of the *Watershed Explorer*. Select the element you wish to rename by clicking on it in the *Watershed Explorer*; it will become highlighted. Keep the mouse over the selected element and click the left mouse button again. The highlighted name will change to editing mode as shown in Figure 82. You can then move the cursor with the arrow keys on the keyboard or by clicking with the mouse. You can also use the mouse to select some or all of the name. Change the name by typing with the keyboard. When you have finished changing the name, press the **Enter** key to finalize your choice. You can also finalize your choice by clicking elsewhere on the "Components" tab. If you change your mind while in editing mode and do not want to rename the selected hydrologic element, press the **Escape** key.

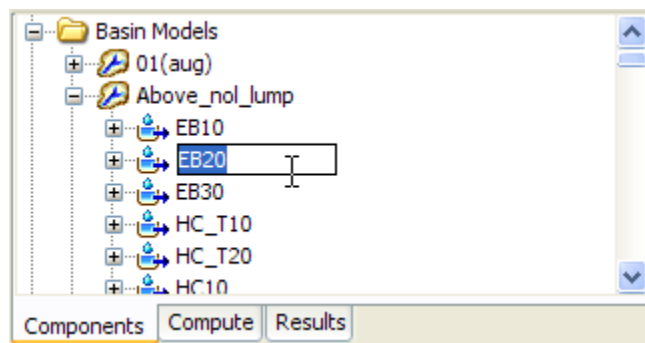

Figure 82. Renaming an element in the *Watershed Explorer*. You can right-click on an element and select the **Rename...** command. Alternately, click with the left mouse button on an element that is already selected to immediately enter editing mode and change the name.

### Deleting an Element

There are three ways to delete a hydrologic element. All methods for deleting an element remove it from the basin model. Once an element has been deleted it cannot be retrieved or undeleted.

The first way to perform a deletion is from the *Basin Model Map* window. Select the hydrologic element you wish to delete by clicking on it with the arrow tool. You may also select more than one element in the map. The selected element or elements become highlighted after the selection. After you make a selection, place the mouse over a selected element and press the right mouse button (Figure 83). A



context menu is displayed that contains several choices including delete. Click the **Delete Element** command. A window will open where you must confirm that you wish to delete the selected hydrologic element. Press the **OK** button to delete the element or elements. If you change your mind and do not want to delete the element selection, press the **Cancel** button or the **X** button in the upper right to return to the *Basin Model Map* window.

The second way to delete an element also uses the selection in the map. Select one or more elements that you wish to delete. Press the **Delete** key on the keyboard. You will have to confirm your choice to delete.

The third way to delete is from the "Components" tab of the *Watershed Explorer*. Move the mouse over the element you wish to delete and press the right mouse button as shown in Figure 84. A context menu is displayed that contains several choices including delete. Click the **Delete** command. You will have to confirm your choice to delete.

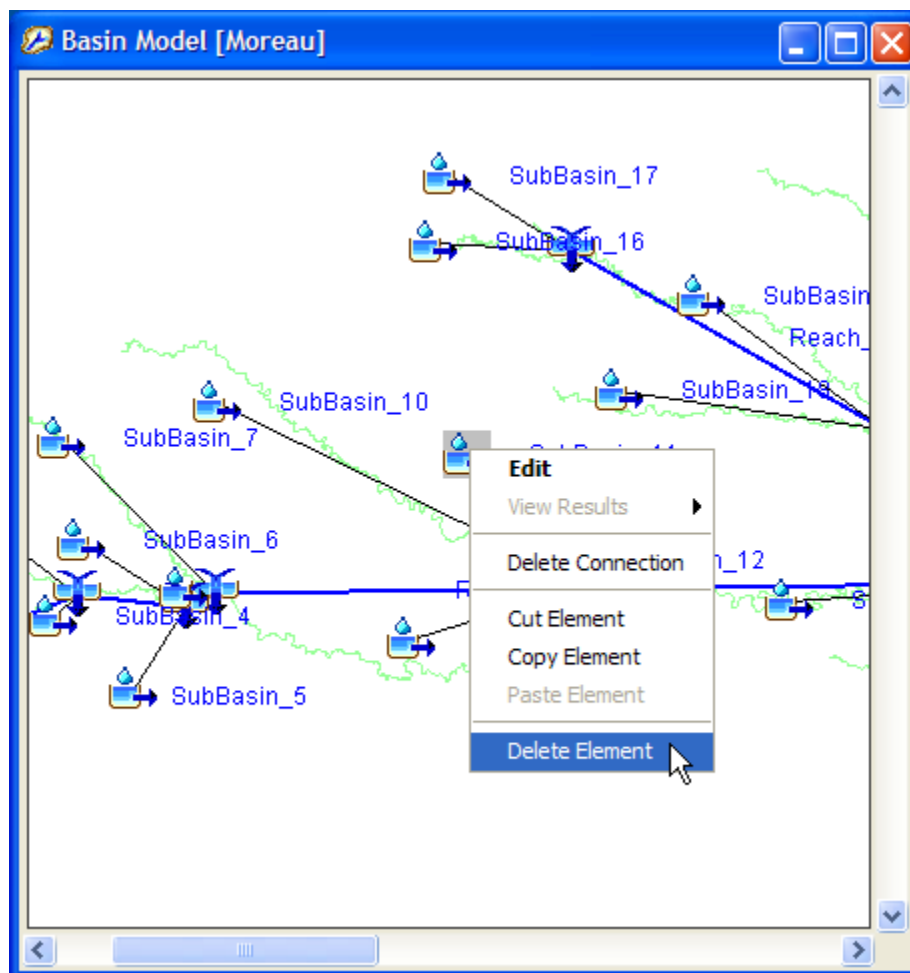

Figure 83. Deleting a subbasin element in the basin map.

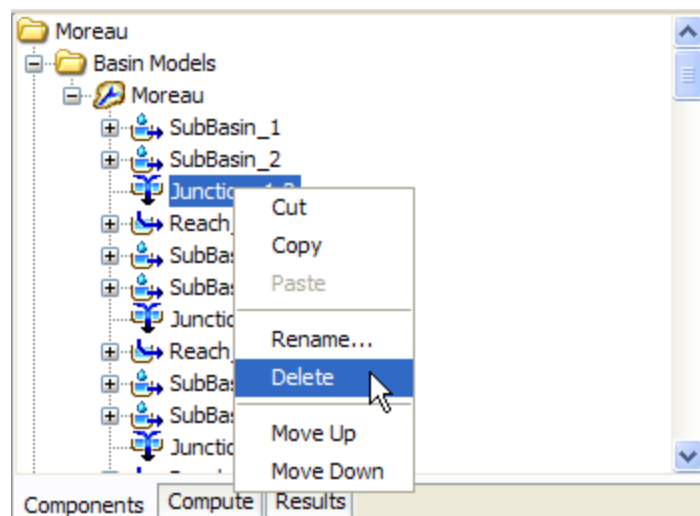

Figure 84. Deleting a junction element in the Watershed Explorer.

### Optional Element Properties

Several optional features are available at every hydrologic element regardless of the type of element. While some of the features may be required for certain capabilities such as parameter estimation with optimization, they are all optional for normal use in simulation runs. All optional features are contained in a *Component Editor* that is automatically displayed along with the main element editor. Select an element in the *Watershed Explorer* or the basin map to view its *Component Editor* (Figure 85).

A time-series discharge gage can be specified as observed flow for any hydrologic element. When used with subbasins, the gage should generally represent the measured flow at the outlet of the subbasin. For reaches, the gage should represent the measured flow at the downstream end of the reach. For all other elements it should be a measured estimate of the outflow from that element. The observed flow is added to the time-series results for the element and appears in summary tables, time-series tables, and graphs.

A time-series stage gage can be specified as observed stage for any hydrologic element. When used with subbasins, the gage should generally represent the measured stage at the outlet of the subbasin. For reaches the gage should represent the measured stage at the downstream end of the reach. For all other elements it should be a measured estimate of the stage at that element. The observed stage is added to the time-series results for the element. It is best used in combination with the elevation-discharge curve described next.

A gage for observed snow water equivalent (SWE) can be added to subbasins. This can be helpful when calibrating simulations that

include modeling the accumulation and melting of a snowpack. The observed data can represent either measurements at a point, or may be the result of external averaging calculations for the whole subbasin. Observed SWE is only available for subbasin elements.

A gage for observed pool elevation can be added to reservoirs. This can be helpful when calibrating simulations. Using this data can be nearly equivalent to having observed inflow to the reservoir. Even when observed inflow is available, the observed flow for an element should be compared to the computed outflow. Observed pool elevation is only available for reservoir elements.

The screenshot shows a software interface for editing element properties. At the top, there are five tabs: 'Subbasin', 'Loss', 'Transform', 'Baseflow', and 'Options', with 'Options' currently selected. Below the tabs, the 'Basin Name' is 'Post Dam' and the 'Element Name' is 'Deer Cr'. There are five rows of input fields, each with a dropdown menu and a small icon to its right:

- Observed Flow: --None--
- Observed Stage: --None--
- Observed SWE: --None--
- Elev-Discharge: --None--
- Ref Flow (M3/S): 3.4
- Ref Label: Flood Warning

Figure 85. Element component editor for specifying option properties.

The program fundamentally computes flow for each of the hydrologic elements included in a basin model. An elevation-discharge curve can be specified so that stage can be computed as well. If a curve is specified, the stage for each time step is determined by taking the computed flow and using it to interpolate elevation from the curve. The computed stage is added to time-series results for the element and appears in summary tables, time-series tables, and graphs.

The flow ratio is only shown for subbasin and source elements, and only if the basin model is set to allow flow ratios. To enable or disable flow ratios, access the *Component Editor* for the basin model and make the desired selection. When the ratios are enabled in the basin model, the flow ratio can be entered for subbasin and source elements. The ratio is applied to the computed flow from the subbasin or source in order to compute the final outflow.

A reference flow can be specified to assist in interpreting computed flow results. The flow is added to the element results graph as a horizontal marker line at the specified flow value. The marker line is labeled with the specified label. The reference flow can represent any

significant flow value such as bank-full discharge, flood watch, levee overtopping, or observed high water mark for a storm event.

### **Element Inventory**

The element inventory provides a listing of some or all of the hydrologic elements in a basin model. This is helpful for reviewing the various element names and descriptions. To access the inventory, click the **Parameters** menu and select the **Element Inventory** command. A sample inventory is shown in Figure 86. If there is a current element selection, only the selected elements will be shown in the inventory when the window opens; you can switch to showing all elements by using the selection control at the top of the window. All hydrologic elements in the basin model will be shown if no elements are currently selected.

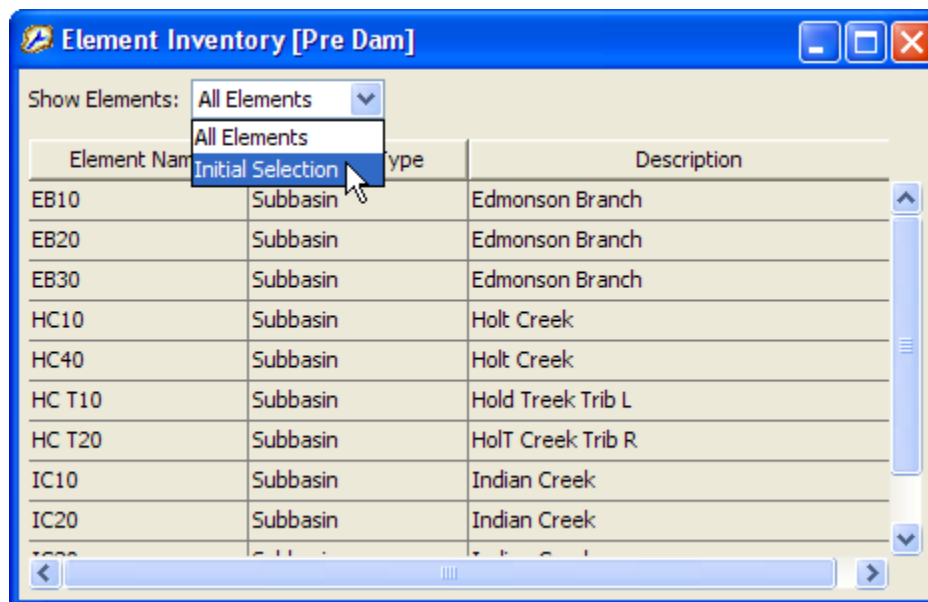

Figure 86. Typical element inventory for a basin model. You can switch between viewing the initial element selection from the basin map, or all elements.

### **Finding and Selecting Elements**

The simplest way to find a hydrologic element in a basin model is to select it in the *Watershed Explorer*. All of the elements in a basin model are shown in hydrologic order under the basin model icon. Click on an element icon in the *Watershed Explorer* and it will become selected. The selected element is highlighted in the *Watershed Explorer* and in the *Basin Model Map* window. More than one element may be selected at a time but only the *Component Editor* for the first selected element is shown.

You can also find and select a hydrologic element in the *Basin Model Map* window. Begin by making sure the *Arrow Tool* is selected on the toolbar. Examine the element icons in the *Basin Model Map* window until you find the one you wish to select. Click on it with the arrow cursor and it will become selected. The selected element is highlighted in the *Basin Model Map* window and in the *Watershed Explorer*. After you make the first selection, you can add to the selection by holding the shift key and clicking on additional elements. You can select several elements simultaneously by using the arrow cursor to drag a box around the desired elements. To select using a drag box, move the mouse to a blank area of the map. Hold the left mouse button and drag the mouse. A box is drawn to show which elements will be selected when you release the mouse button.

It can be difficult to find a specific hydrologic element in a large basin model with many elements. A special tool is included that can be used to help locate a single element or a group of elements. Access the tool by clicking the **Edit** menu and selecting the **Select Special** command (Figure 87). The *Select Special* window will remain open until it is closed by pressing the **Close** button or the **X** button at the upper corner of the window. Elements are selected in the basin model according to the selections on the *Select Special* window every time the **Apply** button is pressed. There are three components to a special selection.

The first component of a special selection is the element name. You may enter a specific name, for example, the name of an element appearing in an error message. You can find all elements that begin with a specific sequence of letters by entering those letters followed by an asterisk. For example, entering `sub*` will find all elements with names that start with "sub". You can also find all elements that end with a specific sequence of letters by entering an asterisk followed by those letters. For example, entering `*creek` will find all elements with names that end in "creek". Finally you can find all elements that contain a specific sequence of letters by entering an asterisk, the letters, and ending with another asterisk. For example, entering `*basin*` will find all elements with names that contain "basin". By default the "Element Name" is set to an asterisk so that the special selection will find all element names.

The second component of a special selection takes the result of limiting by element name and further limits it based on the element type. Elements will only be selected if they match the name criteria and their type is checked on. For example, to only search among the source elements, check off all element types except source. You may check on one, several, or all element types. The default is to search among all element types.

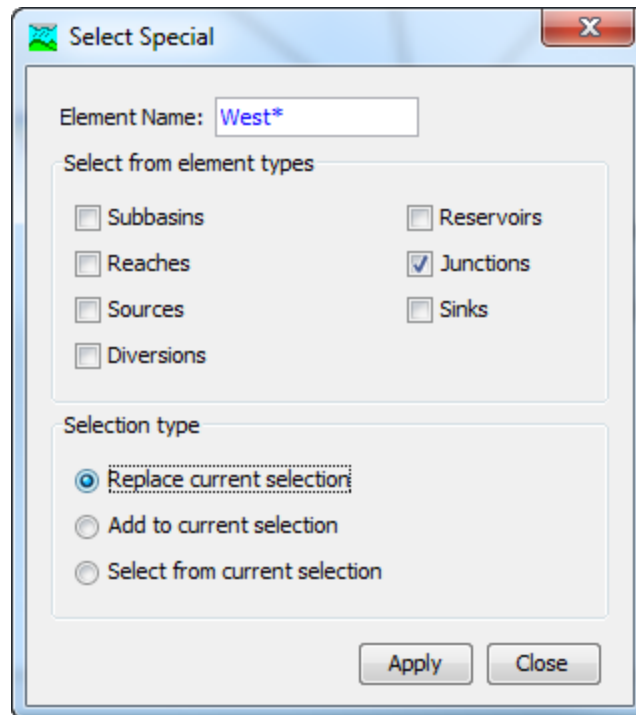

Figure 87. Using the special selection tool to select all junctions whose names begins with the letters "West".

The third component of a special selection is the selection type to create. You may replace the current selection. This means that whatever elements are found to meet the name criteria and the element type criteria will become the selected elements. Any previously selected elements will no longer be selected. You may alternately add to the current selection. This means the new selection will include any elements that are currently selected plus the elements that meet the new name and element type criteria. Finally, you can select from the current selection. In this case the name and element type criteria are further limited by only selecting from among the elements that are already selected.

## Flow Network

The flow network is the skeleton that connects hydrologic elements together into a representation of the stream system in the watershed. Each link in the network is a one-way connector that takes outflow from an element and connects it as inflow to a downstream element. The connection information of the flow network along with the drainage area at each element is used to sort the elements in hydrologic order.

### Moving Elements

Hydrologic elements are moved in the *Basin Model Map* window; they are moved the same way regardless of whether they are connected to

a downstream element. To move an element, start by selecting the *Arrow Tool* from the toolbar. Next click the icon of the element you wish to move; it will become highlighted. Keep the mouse over the element and hold the left mouse button. Drag the mouse until the element icon is in the desired location. Release the left mouse button to finalize the move.

Reach elements are often connected between two junctions or possibly between other element types. Reach elements must connect to the upstream and downstream element. If a reach is connected on both ends, it can only be moved by moving the upstream or downstream element. If a reach is not connected on one end, that free end can be moved. Click on the reach once with the mouse to select it. Move the mouse over the free end of the reach and click again with the left mouse button. A small blue box appears at the free end. Keep the mouse over that box and hold the left mouse button. Drag the mouse to move the free end of the reach. Release the left mouse button to finalize the new location for that end of the reach. If a reach is not connected on either end, the entire reach can be moved. Click on the reach once with the mouse to select it. Keep the mouse over the reach and hold the left mouse button. Drag the mouse to move the reach to a new location. Release the left mouse button to finalize the new reach location.

More than one element can be moved at a time. To move multiple elements, the user must select the elements that will be moved. You may select the elements one at a time. Begin by clicking the first element. Subsequently, hold the control key and click additional elements. A selected element can be unselected by holding the control key and clicking it again. You may also select elements by dragging a box while the arrow tool is selected. You could also select elements using the **Select Special** command on the **Edit** menu. After selecting all desired elements, use the arrow keys on the keyboard to move the elements. The elements will move one distance increment each time an arrow key is pressed. The elements can be moved in smaller distance increments by holding the control key while pressing the arrow keys.

### ***Rescaling Elements***

The best practice for creating basin models is to add background maps before creating any elements. However, sometimes a suitable background map is not immediately available and must be added later. At other times it is desirable to add elements from a different basin model into the current basin model. In both situations it is rare that the elements are at the correct locations or even in the same scale. For example, the elements already in a basin model may have horizontal

units that range from 100 to 125. A background map that must be added may have horizontal units that range from 10,000 to 15,000. A similar situation applies when combining elements from multiple basin models. In these cases it is necessary to rescale the elements so they cover the same range as a background map or a different set of elements. This rescaling should be done before attempting to merge all the elements into a single flow network.

The **Rescale Elements** command on the **View** menu can be used to adapt elements to a background map or elements from another basin model. Begin by selecting two or more elements in the *Basin Model Map* window. Choose the appropriate command from the Rescale Elements menu command. Selecting the **25%** or **50%** option will reduce the area covered by the elements, while selecting the **150%** or **200%** will increase the area covered by the elements. The elements will anchor to the bottom, left corner. When the scale of the elements is reduced, the elements will shift from the top toward the bottom, and from the right edge toward the left. Conversely, when the scale of the elements is increased, the elements will shift up and to the right. The scaling is applied linearly so that elements in the middle of the group move half as much as elements at the top or right edge of the group.

### ***Locking Element Locations***

Moving elements is an important part of creating a basin model. It is usually not necessary to perform moves once all elements have been created and connected in the flow network. However, elements could be accidentally moved small distances then they are selected depending on the user's skill with a mouse and the sensitivity settings of the mouse hardware. You can lock element locations to avoid such accidental moves. The **View** menu includes a **Lock Element Locations** command that toggles between permitting element moves and locking the element locations to prevent moves. Once the locking is selected, it is no longer possible to move elements. Unselect the locking option if you wish to move elements.

### ***Connecting and Disconnecting Elements***

Hydrologic elements can be connected or unconnected from the network using two different methods. The first method uses the mouse in the *Basin Model Map* window. The second method is found on the *Component Editor* for the element.

To connect an element in the *Basin Model Map* window, start by selecting the *Arrow Tool* from the toolbar. Next move the mouse over the element you wish to connect to a downstream element, then press the right mouse button. A context menu is displayed which includes the **Connect Downstream** command. If the element is already



connected, the command will not appear on the menu. After you click the **Connect Downstream** command, the cursor will change to cross hairs as shown in Figure 88. Move the mouse to position the cross hairs over the element to which you wish to connect. Once the mouse is positioned, press the left mouse button. A connection link will be shown between the upstream and downstream elements.

To disconnect an element in the *Basin Model Map* window, start by selecting the *Arrow Tool* from the toolbar. Next click the icon of the element you wish to disconnect from its downstream element; the element you click will become highlighted. Click the right mouse button to see a context menu that includes **Delete Connection**. If the element is not connected, the command will not appear. After you click the **Delete Connection** command, the connection link between the upstream and downstream element will be removed.

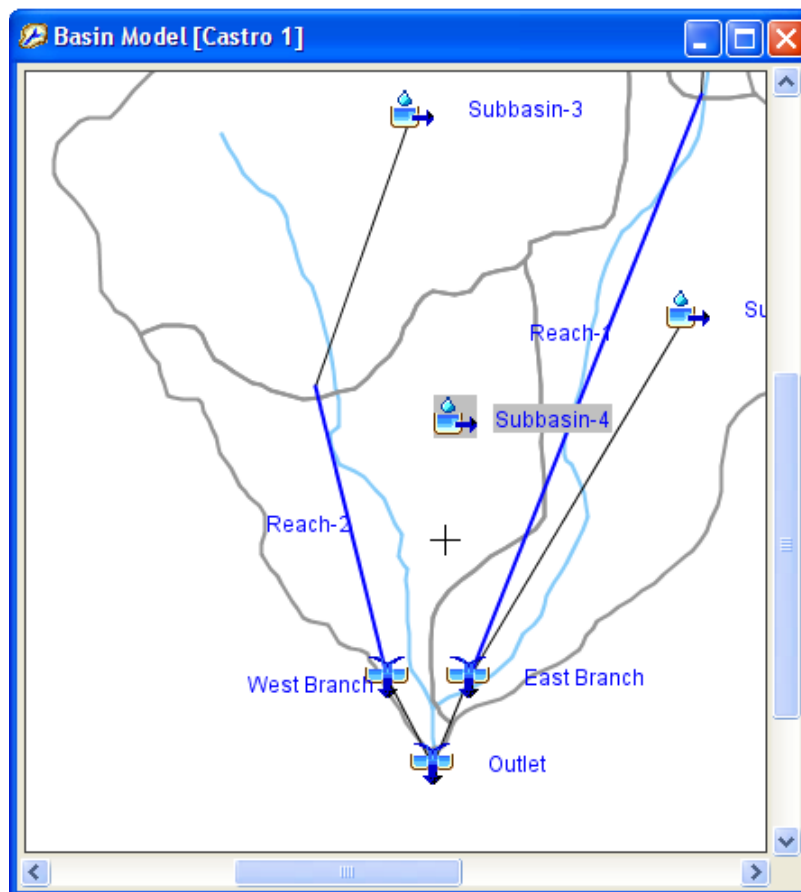

*Figure 88. Preparing to connect the subbasin downstream to West Branch junction. The process was started by placing the mouse over Subbasin-4 and pressing the right-mouse button. Then the **Connect Downstream** command was selected. Note the mouse has changed to a cross hairs cursor for selecting the desired downstream element.*

You can also create and delete connections from the *Component Editor* for the element (Figure 89). To access the *Component Editor*, click on the desired element in the *Basin Model Map* window, or on the "Components" tab of the *Watershed Explorer*. The *Component Editor* shows the downstream element. If the element is not connected to a downstream element, the selection list will show *None* as the selected element. To connect the element currently shown in the *Component Editor*, select an element on the list. Only elements that could potentially be downstream of the current element are shown. To disconnect the current element, change the selection in the list to the *None* selection.

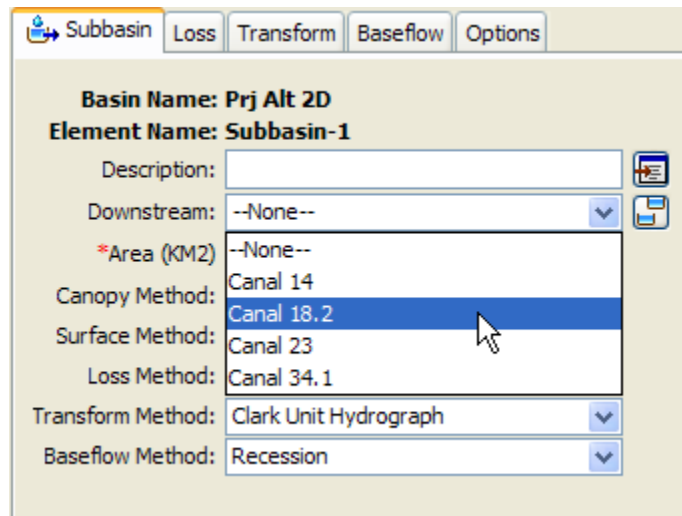

Figure 89. Selecting a downstream element using the subbasin component editor. The selection list shows all of the elements that can be downstream of the subbasin.

## Hydrologic Order

Hydrologic order means that elements from the basin model are shown in order from the headwaters to the outlet. The key properties used to determine hydrologic order are the flow network connections and drainage area. From each element in the basin model it is possible for the program to automatically determine the downstream element, and the upstreams elements. These connections create the basic structure of the network. The area entered for subbasins and sources is used to determine the drainage area for any other downstream element in the network. While area is optional in source elements for many purposes, the hydrologic order downstream of a source cannot be properly determined if the area is not specified. A simple basin model is shown in Figure 90, with the corresponding *Watershed Explorer* shown in Figure 91.

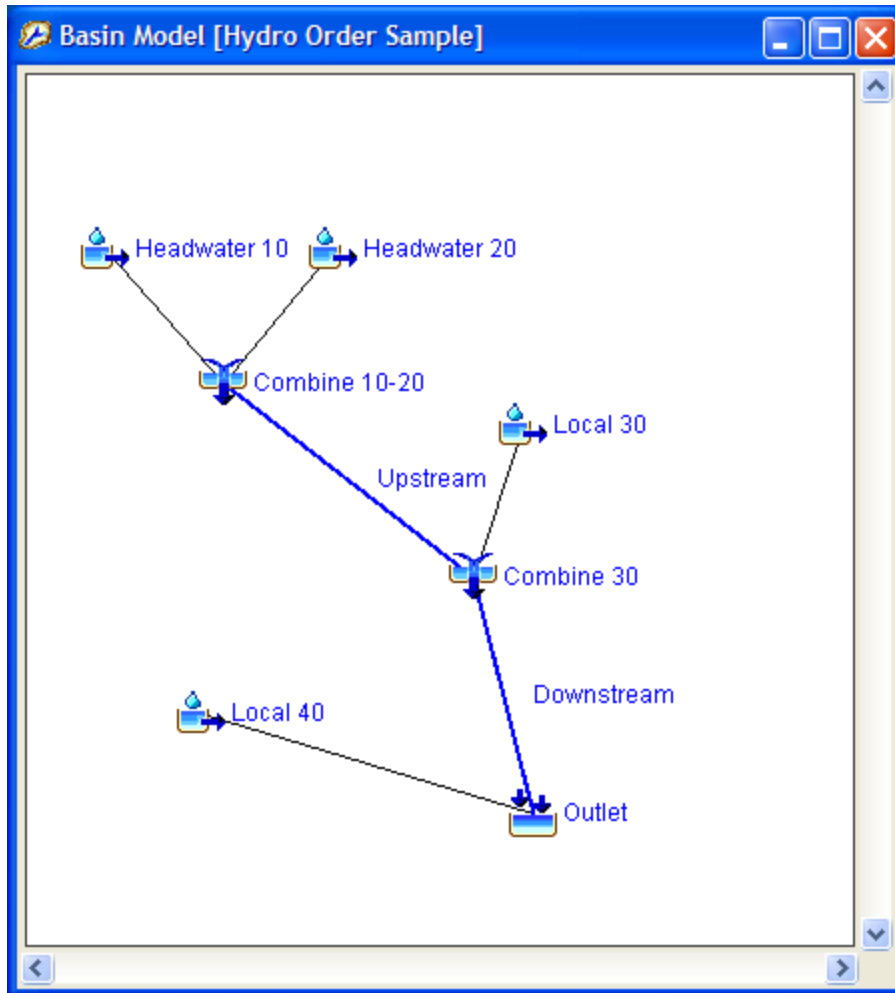

Figure 90. A simple basin model for demonstrating hydrologic order.

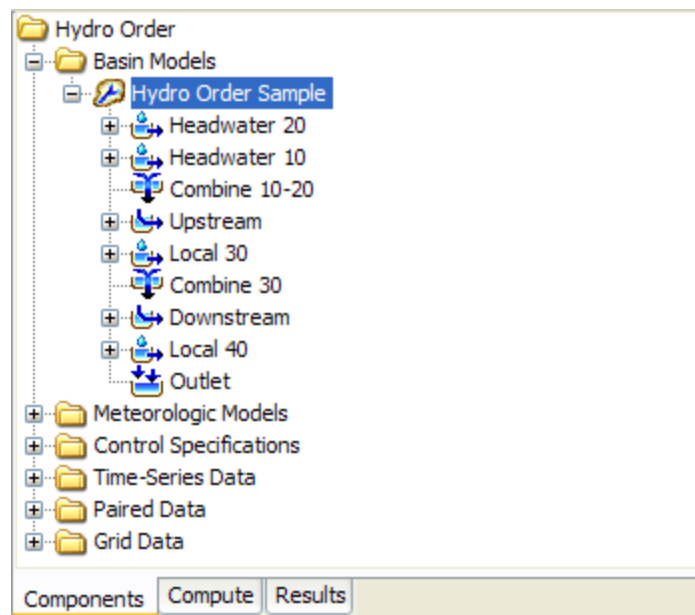

Figure 91. Watershed Explorer showing hydrologic order corresponding to the elements shown in Figure 90.

The hydrologic order shown in the *Watershed Explorer* is maintained automatically. Elements added to the basin model are automatically sorted into correct hydrologic order. When an element is connected to the flow network, or disconnected, the hydrologic order will be automatically updated to reflect the change. Any changes to area for a subbasin or source element will automatically update drainage areas throughout the flow network, and if necessary update the hydrologic order.

The hydrologic order is determined beginning from the outlet element. The outlet element is placed at the bottom of the element list shown in the *Watershed Explorer*. Next the drainage areas of the elements immediately upstream of the outlet are compared. The element with the smaller drainage area is placed closest to the outlet, and the element with the larger drainage area is placed furthest. The process of comparing the drainage areas of the upstream elements is then repeated element by element until all elements have been sorted. In the case shown in Figure 91, the drainage area of the "Headwater 20" subbasin is larger than the drainage area of the "Headwater 10" subbasin.

Some basin models have more than one outlet. When this is the situation, each outlet and its upstream elements are sorted as outlined above. A second level of sorting is then carried out using the drainage area of each outlet. The outlet with the largest drainage area appears at the bottom of the *Watershed Explorer*, with its upstream elements above it. The outlet with the smallest drainage area appears at the top of the *Watershed Explorer*, with its upstream elements above it.

In some situations the automatic sorting of hydrologic elements may not achieve the desired result. Manual adjustments may be made to the order, and the adjusted order is then maintained as the new hydrologic order. Two methods exist for making manual adjustments. The first option is to click on an element in the *Watershed Explorer* so that it is selected. Next, right click on the element and choose either the **Move Up** or the **Move Down** menu command, as shown in Figure 92. The selected element will be moved up or down one position in the element ordering. Repeated moves will be necessary in order to move the element up or down more than one position. You may also select a contiguous block of elements and move all of them up or down position in unison.

Any selected element in the *Watershed Explorer* can be moved several positions at once using the mouse. Start by clicking on an element to select it. Next, carefully position the mouse over the selected element and hold the left mouse button, and then drag the mouse. The shape of the cursor will change while you drag the element and you will also see an insertion, as shown in Figure 93. The insertion line shows where the element will be placed when you release the mouse button. Drag the mouse up or down over the other elements until you position the mouse where you want the element, and then release the button. The element will be moved to the new position in the hydrologic order.

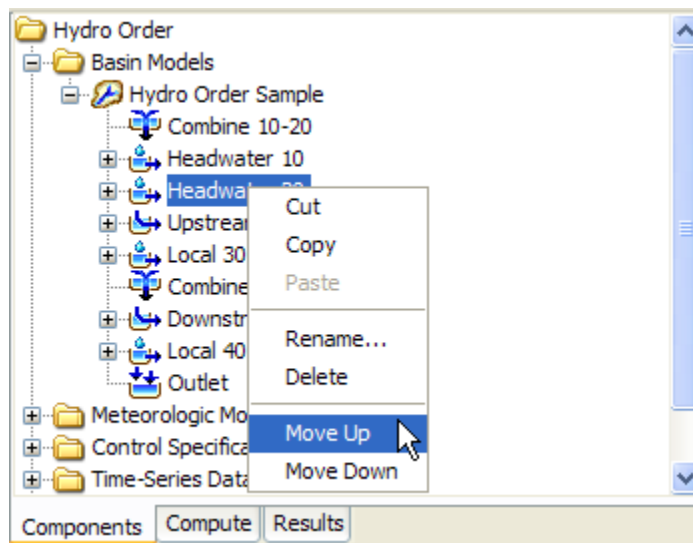

Figure 92. Manually moving an element in the hydrologic order using the right mouse menu.

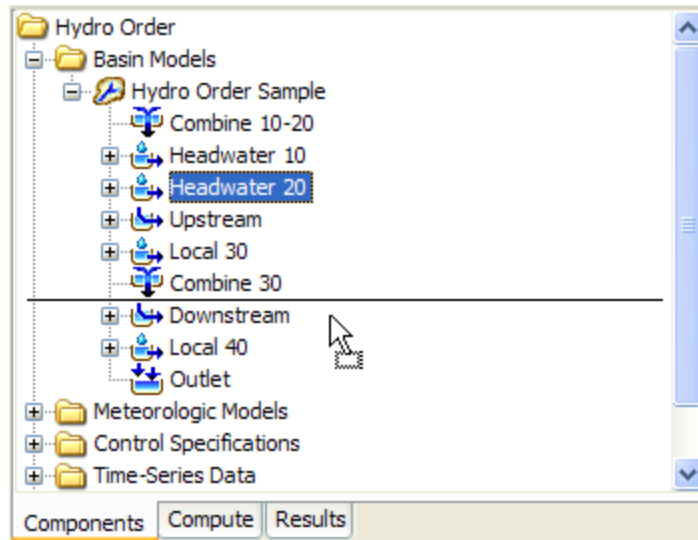

Figure 93. Manually moving an element in the hydrologic order by dragging it and dropping into position. The insertion line shows the drop location.

Global editors and simulation results shown throughout the program will display elements in hydrologic order, as shown in the *Watershed Explorer*. Hydrologic order will be used when the editor or result is first opened. However, each result window also includes a selection choice for switching between hydrologic order and alphabetic order.

### Locking Hydrologic Order

Sometimes the downstream connection of an element needs to be changed in the flow network. Other times it is necessary to add an element to the basin model. In these cases it is helpful to have the automatic hydrologic ordering of the elements. The remainder of the time it is not necessary to change the hydrologic ordering. In fact, if many manual adjustments have been made to the hydrologic ordering, the ordering should be preserved against accidental resorting or adjustment. You can lock the hydrologic order to avoid such accidental changes. The **View** menu includes a **Lock Hydrologic Order** command that toggles the setting.

When **Lock Hydrologic Order** is disengaged, it is possible to resort the elements using the right mouse menu for the basin model in the *Watershed Explorer*. It is also possible to make manual adjustments using the right mouse menu for an element in the *Watershed Explorer*, or by dragging the element with the mouse. The ordering will also be updated as elements are added in the basin model, or downstream flow connections are changed.

When **Lock Hydrologic Order** is engaged, it is not possible to make any manual adjustments to the element order. Right mouse menus

and mouse dragging will be disabled. Any elements added to the basin model will be put at the bottom of the element list. Elements will not move in the hydrologic order even if downstream flow connections are changed. You will need to turn off the locking in order to make any changes.

## Zones

Zones provide a way to group together elements with similar properties. The grouping could be performed spatially so that a large watershed is subdivided with a separate zone for each tributary. Another way to subdivide spatially is to group all subbasins between upstream and downstream gage locations. Alternatively, the grouping could be performed parametrically so that a watershed is subdivided with a separate zone for each type of land use. The properties used to group elements into zones are defined by the user and may use any meaningful criteria. Zones are defined and managed as part of the basin model. Once defined, the primary use of zones is for setting parameter values within the *Forecast Alternative*, described fully in a later chapter. In brief, during a forecast it becomes possible to set parameter values once and have them immediately applied to all subbasins in a zone.

There are three organizational levels to the use of zones. The lowest organizational level is individual subbasins. The subbasins contain the actual parameter data and are located within the watershed. The middle organizational level is a *Zone*. Each *Zone* contains one or more subbasins. Subbasins are grouped into zones using one of the schemes described in the previous paragraph. The highest level is a *Zone Configuration*. Each *Zone Configuration* includes one or more *Zones*. A *Basin Model* may include multiple configurations.

### **Creating a New Zone Configuration**

A new zone configuration is created using the *Zone Configuration Manager*. To access the manager, click on the **Parameters** menu and select the **Zone Configuration Manager** command. The manager will open and show all of the zone configurations currently in the basin model (Figure 94). The manager can remain open while you manage the zone configurations or while you perform tasks elsewhere in the program. You can close the manager using the **X** button in the upper right corner. The buttons to the right of the zone configuration list can be used to manage existing configurations or create a new one. To create a new zone configuration, press the **New...** button. After you press the button a window (Figure 95) will open where you can name and describe the new zone configuration that will be created. A default name is provided for the new configuration; you can use the default or

replace it with your own choice. A description can also be entered. If the description is long, you can press the button to the right of the description field to open an editor. The editor makes it easier to enter and edit long descriptions. A zone configuration may contain subbasin or reach elements, but it cannot contain both types of elements. Other types of elements cannot be included in a zone configuration. Select the type of element that will be included in the zone configuration. When you are satisfied with the name, description, and element type, press the **Create** button to finish the process of creating the new zone configuration. You cannot press the **Create** button if no name is specified for the new configuration. If you change your mind and do not want to create a new zone configuration, press the **Cancel** button or the **X** button in the upper right to return to the *Zone Configuration Manager* window.

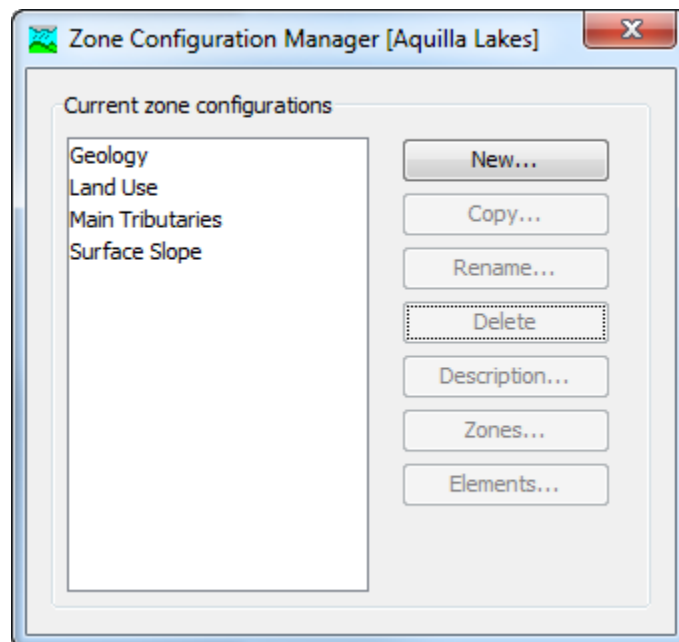

Figure 94. The Zone Configuration Manager showing four configurations with schemes for grouping elements.

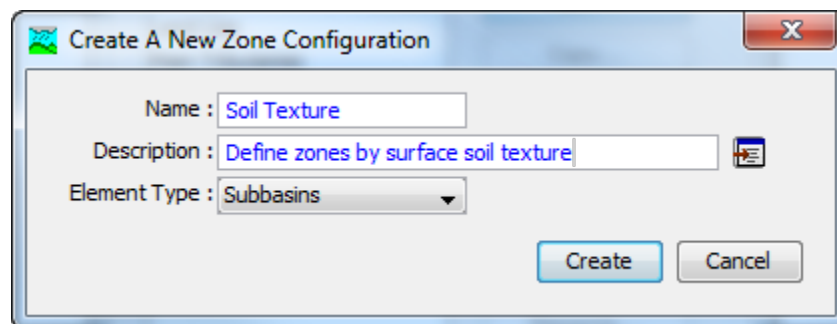

Figure 95. Creating a new zone configuration. This was accessed by opening the Zone Configuration Manager from the *Parameters* menu, and then pressing the **New...** button.



## Copying a Zone Configuration

Copy a zone configuration using the *Zone Configuration Manager*, which is accessed from the **Parameters** menu. Select the zone configuration you wish to copy by clicking on it in the list of current configurations. The selected configuration is highlighted after you select it. After you select a configuration you can press the **Copy...** button on the right side of the window. A new *Copy Zone Configuration* window (Figure 96) will open where you can name and describe the copy that will be created. A default name is provided for the copy; you can use the default or replace it with your own choice. A description can also be entered; if it is long you can use the button to the right of the description field to open an editor. When you are satisfied with the name and description, press the **Copy** button to finish the process of copying the selected basin model. You cannot press the **Copy** button if no name is specified. If you change your mind and do not want to copy the selected zone configuration, press the **Cancel** button or the **X** button in the upper right to return to the *Zone Configuration Manager* window.

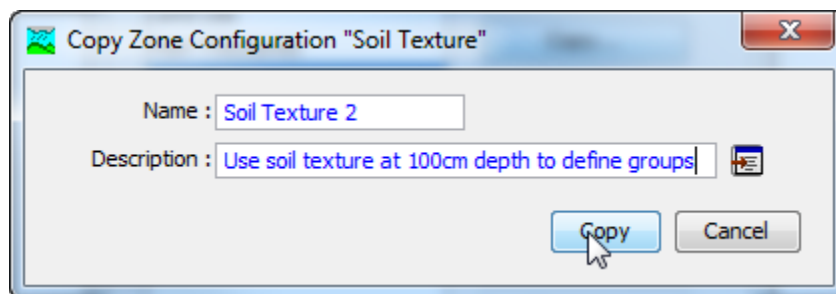

Figure 96. Creating a copy of a zone configuration. This was accessed from the *Zone Configuration Manager*.

## Renaming a Zone Configuration

Rename a zone configuration using the *Zone Configuration Manager*, which is accessed from the **Parameters** menu. Select the zone configuration you wish to rename by clicking on it in the list of current configurations. The selected configuration is highlighted after you select it. After you select a configuration you can press the **Rename...** button on the right side of the window. A new *Rename Zone Configuration* window (Figure 97) will open where you can provide the new name. If you wish you can also change the description at the same time. If the new description will be long, you can use the button to the right of the description field to open an editor. When you are satisfied with the name and description, press the **Rename** button to finish the process of renaming the selected zone configuration. You cannot press the **Rename** button if no name is specified. If you change your mind and do not want to rename the selected zone

configuration, press the **Cancel** button or the **X** button in the upper right of the *Rename Zone Configuration* window to return to the *Zone Configuration Manager* window.

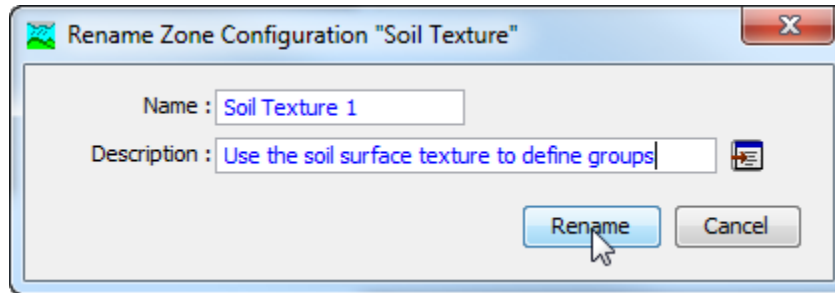

Figure 97. Renaming a zone configuration. This was accessed from the *Zone Configuration Manager*.

### Deleting a Zone Configuration

Delete a zone configuration using the *Zone Configuration Manager*, which is accessed from the **Parameters** menu. Select the zone configuration you wish to delete by clicking on it in the list of current configurations. The selected configuration is highlighted after you select it. Press the **Delete** button on the right side of the window to delete the selected zone configuration (Figure 98). A window will open where you must confirm that you wish to delete the selected configuration. Press the **OK** button to delete the configuration. If you change your mind and do not want to delete the selected zone configuration, press the **Cancel** button or the **X** button in the upper right to return to the *Zone Configuration Manager* window.

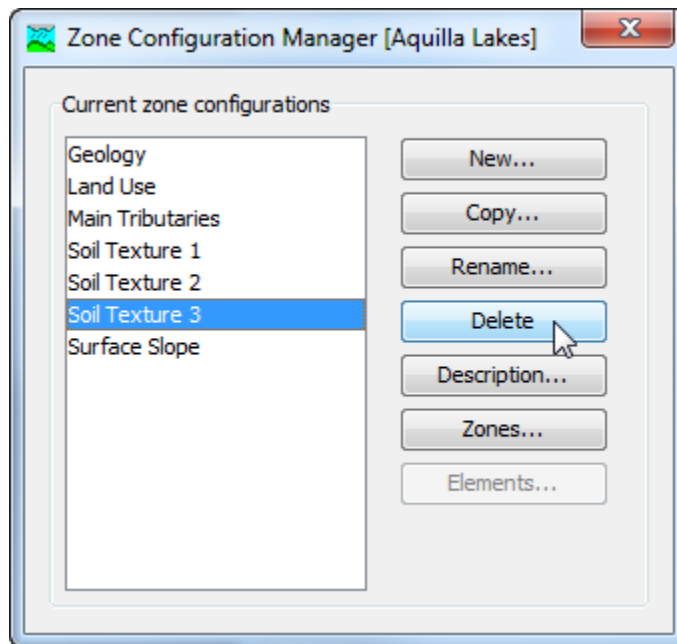

Figure 98. Preparing to delete a zone configuration from the Zone Configuration Manager.

### Creating a Zone in a Configuration

Create a new zone from the *Zones* window, accessed directly from the *Zone Configuration Manager*. To begin, open the zone configuration manager by clicking on the **Parameters** menu and selecting the **Zone Configuration Manager** command. Next select the zone configuration to which you will add a new zone by clicking on the configuration in the list of available configurations. The selected zone configuration is highlighted after you click on it. After you select a zone configuration you can press the **Zones...** button to open the *Zones* window (Figure 99). Finally, press the **New...** button in the *Zones* window to begin creating a new zone. After you press the button a window (Figure 100) will open where you can name and describe the new zone that will be added to the selected zone configuration. A default name is provided for the new zone; you can use the default or replace it with your own choice. A description can also be entered. If the description is long, you can press the button to the right of the description field to open an editor. The editor makes it easier to enter and edit long descriptions. When you are satisfied with the name and description, press the **Create** button to finish the process of creating the new zone. You cannot press the **Create** button if no name is specified for the new zone. If you change your mind and do not want to create a new zone, press the **Cancel** button or the **X** button in the upper right to return to the *Zones* window.

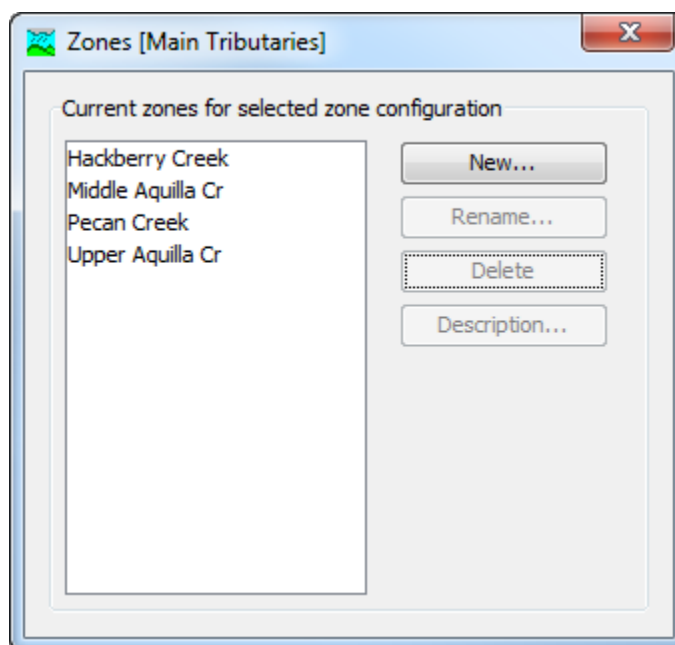

Figure 99. Managing the zones in a zone configuration.

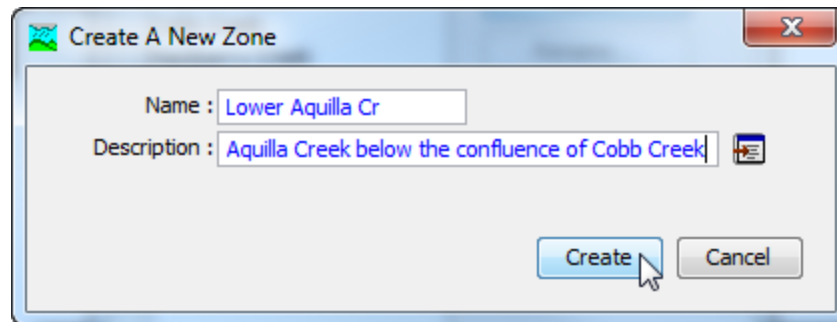

Figure 100. Creating a new zone.

### Renaming a Zone in a Configuration

Rename a zone from the *Zones* window, accessed directly from the *Zone Configuration Manager*. To begin, open the zone configuration manager by clicking on the **Parameters** menu and selecting the **Zone Configuration Manager** command. Next select the zone configuration that contains the zone you wish to rename by clicking on the configuration in the list of available configurations. The selected zone configuration is highlighted after you click on it. After you select a zone configuration you can press the **Zones...** button to open the *Zones* window (Figure 99). Finally, select the zone you wish to rename by clicking on it in the list of zones and then press the **Rename...** button on the right side of the *Zones* window. A new *Rename Zone* window (Figure 101) will open where you can provide the new name. If you wish you can also change the description at the same time. If the new description will be long, you can use the button to the right of the description field to open an editor. When you are satisfied with the name and description, press the **Rename** button to finish the process of renaming the selected zone. You cannot press the rename button if no name is specified. If you change your mind and do not want to rename the selected zone, press the **Cancel** button or the **X** button in the upper right of the *Rename Zone* window to return to the *Zones* window.

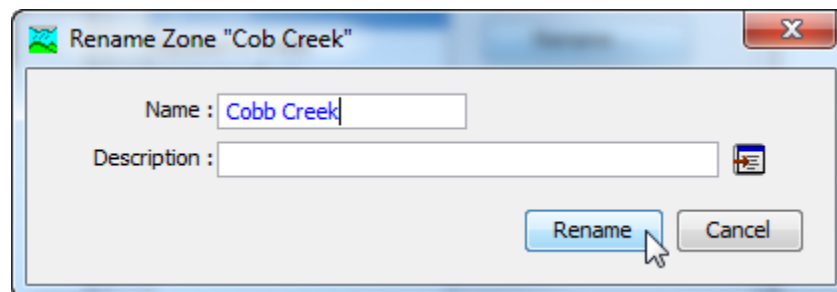

Figure 101. Renaming a zone.

## Deleting a Zone from a configuration

Delete a zone from the *Zones* window, accessed directly from the *Zone Configuration Manager*. To begin, open the zone configuration manager by clicking on the **Parameters** menu and selecting the **Zone Configuration Manager** command. Next select the zone configuration that contains the zone you wish to delete by clicking on the configuration in the list of available configurations. The selected zone configuration is highlighted after you click on it. After you select a zone configuration you can press the **Zones...** button to open the *Zones* window (Figure 99). Finally, select the zone you wish to delete by clicking on it in the list of zones and then press the **Delete...** button on the right side of the *Zones* window, as shown in Figure 102. A window will open where you must confirm that you wish to delete the selected zone. Press the **OK** button to delete the zone. If you change your mind and do not want to delete the selected zone, press the **Cancel** button or the **X** button in the upper right to return to the *Zones* window.

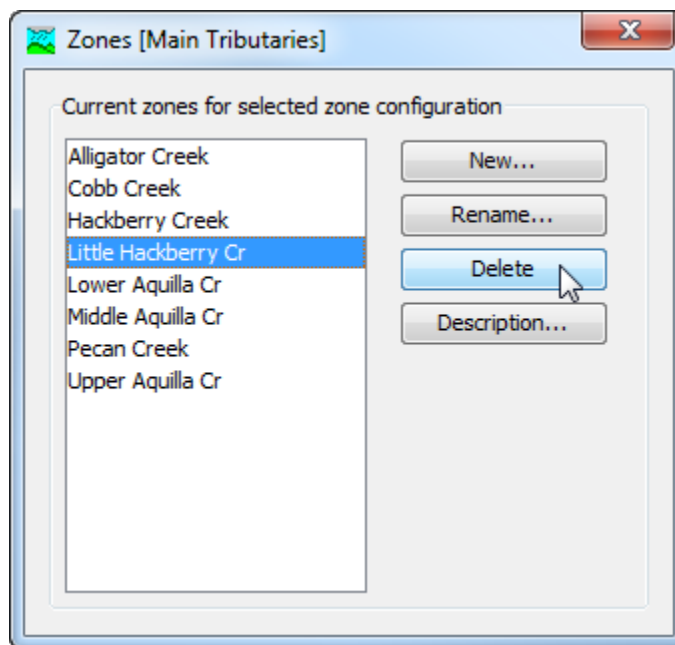

Figure 102. Preparing to delete a zone from a zone configuration. A confirmation will be required after pressing the **Delete** button.

## Adding Elements to a Zone

Add an element to a zone using the *Elements* window, accessed directly from the *Zone Configuration Manager*. To begin, open the zone configuration manager by clicking on the **Parameters** menu and select the **Zone Configuration Manager** command. Next select the zone configuration that contains the zone to which elements will be added. Click on the configuration in the list of available configurations

to select it. The selected zone configuration is highlighted after you click on it (Figure 98). After you select a zone configuration you can press the **Elements...** button to open the *Elements* window.

The left side of the *Elements* window shows all elements that have not been assigned to a zone (Figure 103). The zones selector at the upper right of the window can be used to switch between zones in the selected zone configuration. You must select the zone to which you wish to add elements. The right side of the *Elements* window shows all elements that have been added to the selected zone.

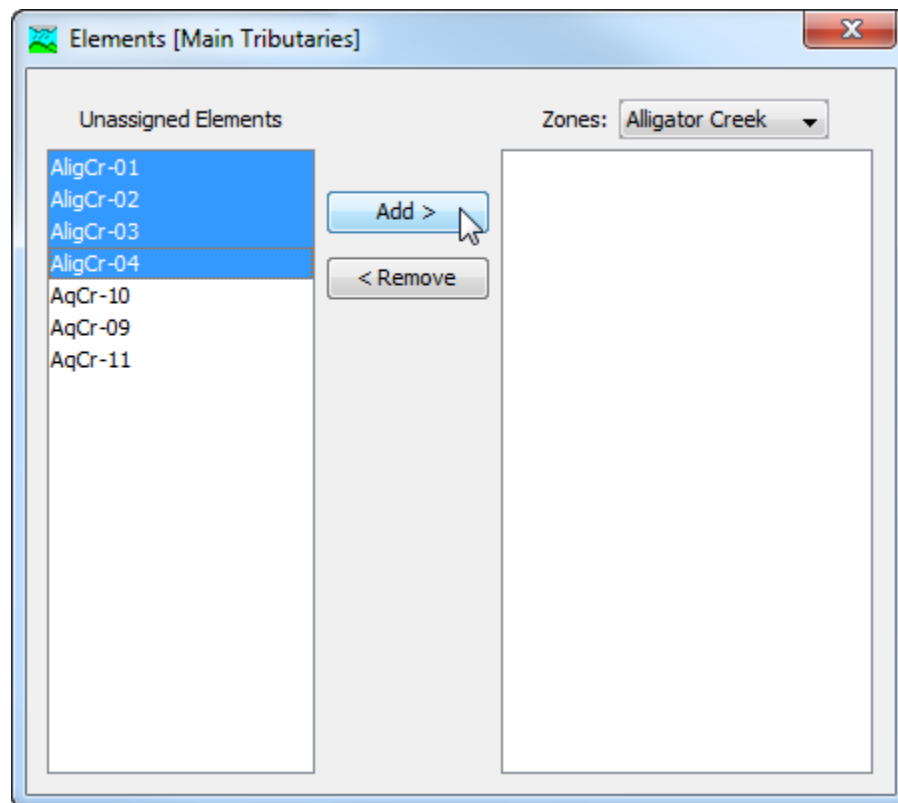

*Figure 103. Elements are added to the selected zone "Alligator Creek" by pressing the **Add** button. Multiple elements were selected by holding the control key and clicking each desired element. Elements can also be added by double-clicking each one in the left panel.*

There are two ways to add an element to the selected zone. The first way is to click on an unassigned element in the left side of the *Elements* window. You may hold the control key and click on additional elements to add more than one element at a time. The selected elements are highlighted after clicking. Press the **Add** button to add the selected elements to the selected zone.

The second way to add an element to the selected zone is to double-click it in the list of unassigned elements. When an element is double-

clicked, it will be added to the currently selected zone and removed from the list of unassigned elements.

### **Removing Elements from a Zone**

Remove an element from a zone using the *Elements* window, accessed directly from the *Zone Configuration Manager*. To begin, open the zone configuration manager by clicking on the **Parameters** menu and select the **Zone Configuration Manager** command. Next select the zone configuration that contains the zone from which elements will be removed. Click on the configuration in the list of available configurations to select it. The selected zone configuration is highlighted after you click on it. After you select a zone configuration you can press the **Elements...** button to open the *Elements* window (Figure 104).

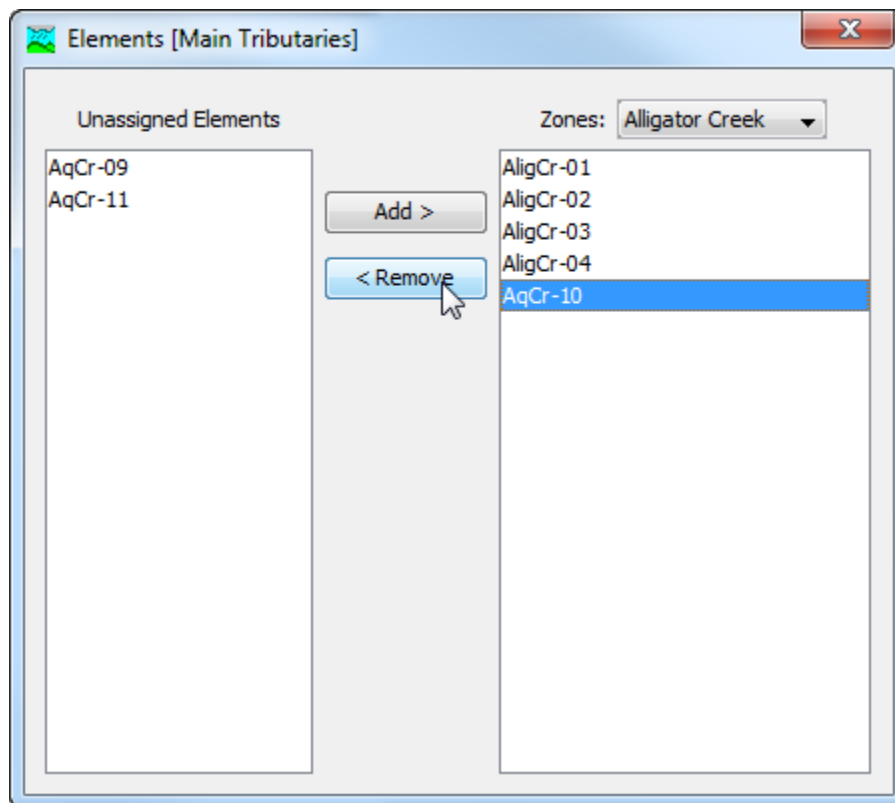

*Figure 104. Elements are returned from the selected zone "Alligator Creek" to the unassigned elements by pressing the Remove button. Elements can also be removed by double-clicking each one shown in the right panel.*

The right side of the *Elements* window shows all elements that have been assigned to a zone. The zones selector at the upper right of the window can be used to switch between zones in the selected zone configuration. You must select the zone from which you wish to

remove elements. The left side of the *Elements* window shows all elements have not been assigned to a zone.

There are two ways to remove an element from the selected zone. The first way is to click on an element in the right side of the *Elements* window. You may hold the control key and click on additional elements to remove more than one element at a time. The selected elements are highlighted after clicking. Press the **Remove** button to return the selected elements to the list of unassigned elements.

The second way to remove an element from the selected zone is to double-click it in the list of zone elements. When an element is double-clicked, it will be removed from the currently selected zone and placed on the list of unassigned elements.

### **Selecting a Current Zone Configuration**

A zone configuration can be selected to be active in the *Basin Model Map* window, global editors, and results accessed through the map. There are two ways to select the current zone configuration. The first way is to click on the **Parameters** menu and select a zone configuration with the **Select Zone Configuration** command. The command shows all zone configurations that have been established in the basin model. The **Select Zone Configuration** command indicates the selected configuration with a checkmark.

The second way to select the current zone configuration is with the selection box on the toolbar. The selection box shows all zone configurations that have been established in the basin model. Use the selection box to choose a zone configuration.



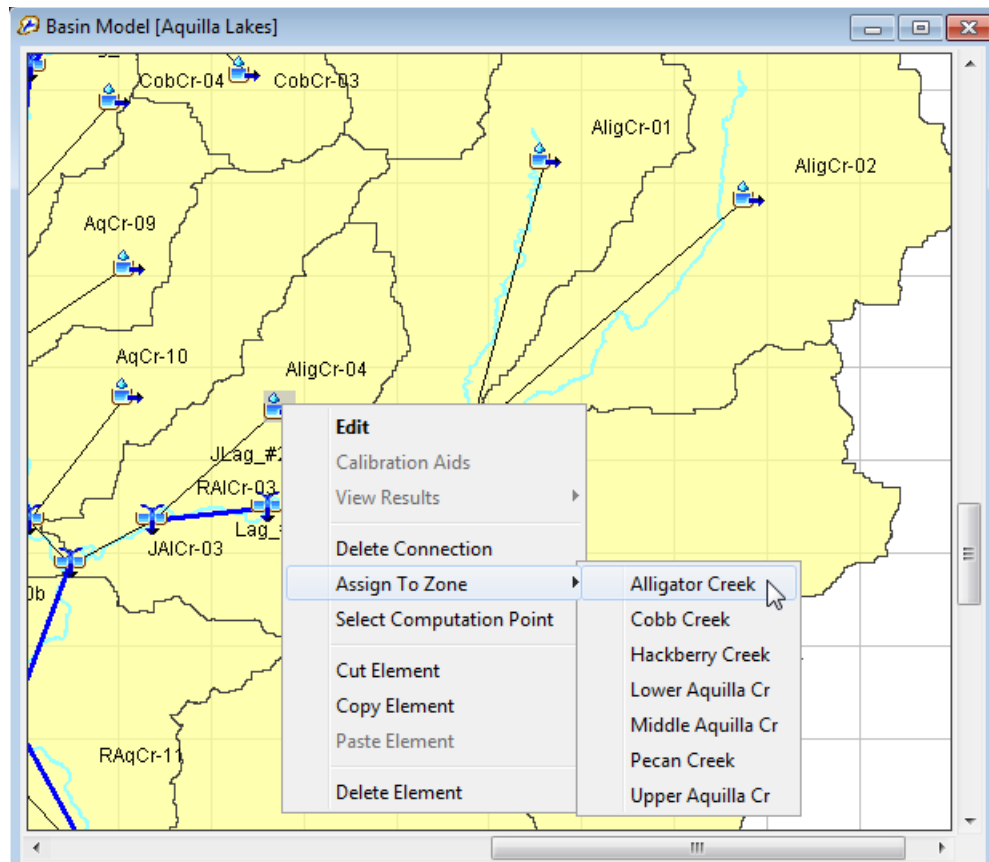

Figure 105. Assigning the "AligCr-04" subbasin to the "Alligator Creek" zone in the current zone configuration.

Elements can be added to a zone or moved between zones using the *Basin Model Map* window once a current zone configuration is selected. To assign or change the assignment of an element, click on the element in the *Basin Model Map* window using the right mouse button. The **Assign To Zone** command shows the zones available for assignment (Figure 105). If the element is not assigned to a zone, it will be assigned to the selected zone. If the element is already assigned, it will be automatically removed from its current zone and assigned to the newly selected zone. Elements assigned to a zone through the map must be assigned one at a time.

Global editors include additional features when there is a current zone configuration. As shown in Figure 106, the global editor can display all elements in the basin model or can be switched to display only the elements in a zone of the current zone configuration. All of the zones are shown in the selection list with a prefix of z: indicating status as a zone. Additional selection items may also be included on the list and are shown with a different prefix.

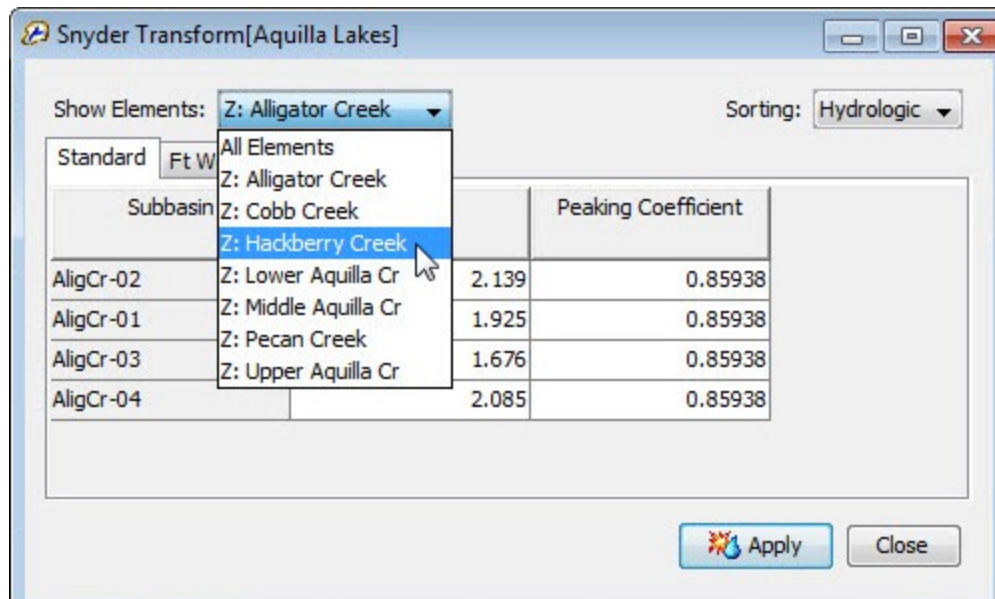

Figure 106. Viewing the parameter data for subbasins assigned to zone "Alligator Creek" in the global editor, and preparing to view the subbasins assigned to zone "Hackberry Creek."

The Global Summary Table also includes additional features when there is a current zone configuration. The global summary table can display all elements in the basin model or can be switched to display elements in a particular zone (Figure 107). All of the zones are shown in the selection list with a prefix of *Z*: indicating status as a zone. Additional selection items may also be included on the list and are shown with a different prefix.

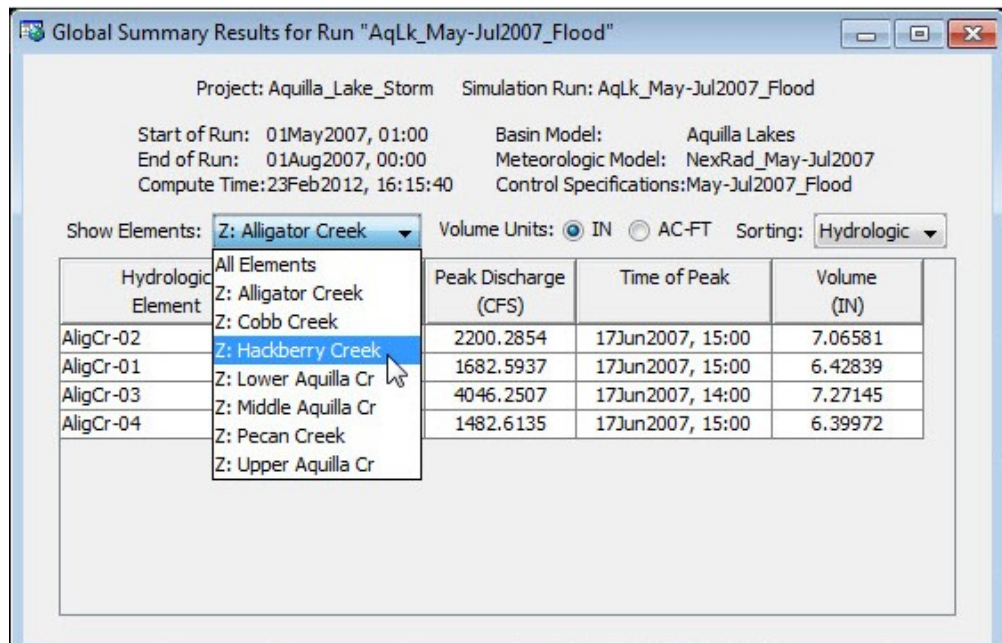

Figure 107. Viewing the results for subbasins assigned to zone "Alligator Creek" in the global summary table, and preparing to view subbasins assigned to zone "Hackberry Creek."

## Computation Points

Elements in the basin model can be designated as computation points. Generally only elements with observed flow, observed stage, or other observed data are designated as computation points. Computation points are designed primarily for use with simulation runs (Chapter 12) and forecast alternatives (Chapter 14). When used with a simulation run, the features of a computation point are a customizable editor that uses slider bars to adjust parameters upstream of the computation point, and result graphs with customizable time-series selection. Results from the simulation run are automatically recomputed as the slider bars are adjusted and the result graphs update dynamically. When used with forecast alternatives, the principal feature of a computation point is to make upstream to downstream calibration more efficient.

### Selecting Computation Points

Any element in the basin model can be selected as a computation point, and there is no limit to the number of computation points permitted. Usually an element is only designated as a computation point if it includes observed data that can aid in calibration. However, observed data is not absolutely necessary.

There are two ways to select an element as a computation point. The first way is to click on the element in the *Basin Model Map* window

using the right mouse button (Figure 108). Choose the **Select Computation Point** command to select the element as a computation point. It is only possible to select the element as a computation point if it is not already selected. An element selected as a computation point shows a small red circle added to the icon in the *Basin Model Map* window and also in the *Watershed Explorer*.

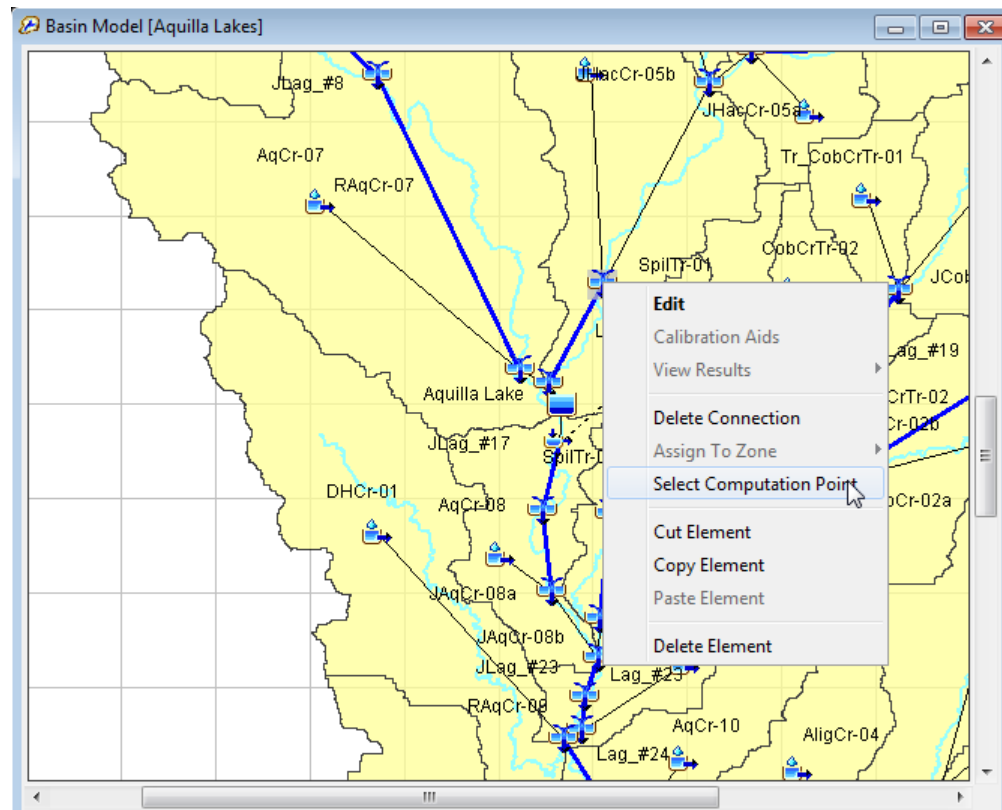

Figure 108. Setting a junction to be a computation point by right-clicking in the basin model map.

The second way to select an element as a computation point is by using the *Computation Point Manager* window (Figure 109). To access the manager, click on the **Parameters** menu and choose the **Computation Point Manager** command. The manager shows all of the elements that have been selected as computation points. Press the **Select Elements** button to begin the process of selecting an element as a computation point. The *Select Elements* window (Figure 110) includes a selection list for choosing the type of element to display in the selection table. The selection table shows the element name and description for all elements in the basin model that match the selected element type. By default only elements with observed data are shown in the table, but all elements can be shown by using the option in the upper right of the window. To select an element as a computation point, click on the row in the table and press the **Select** button. You cannot make a selection unless a row in the table is

selected; the selected row in the table is highlighted. Press the **Close** button when you are done selecting elements and you will return to the *Computation Point Manager* window.

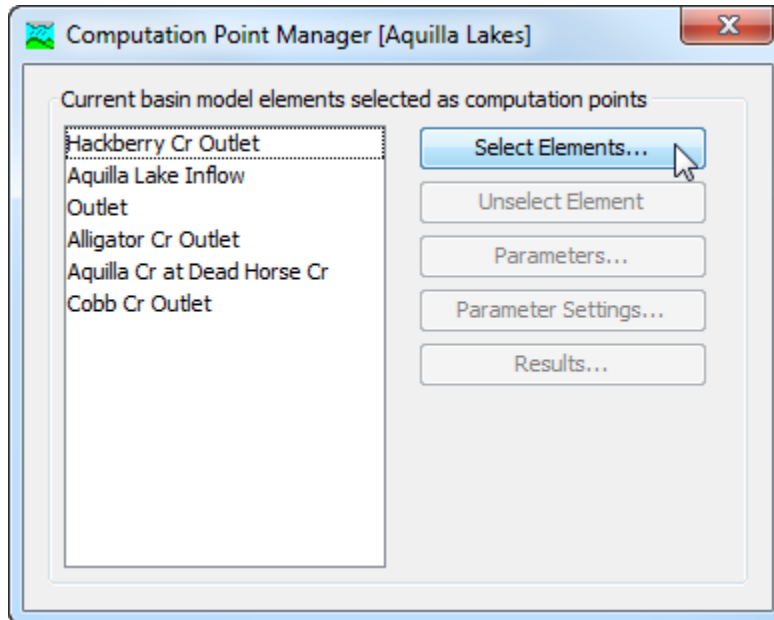

Figure 109. The computation point manager.

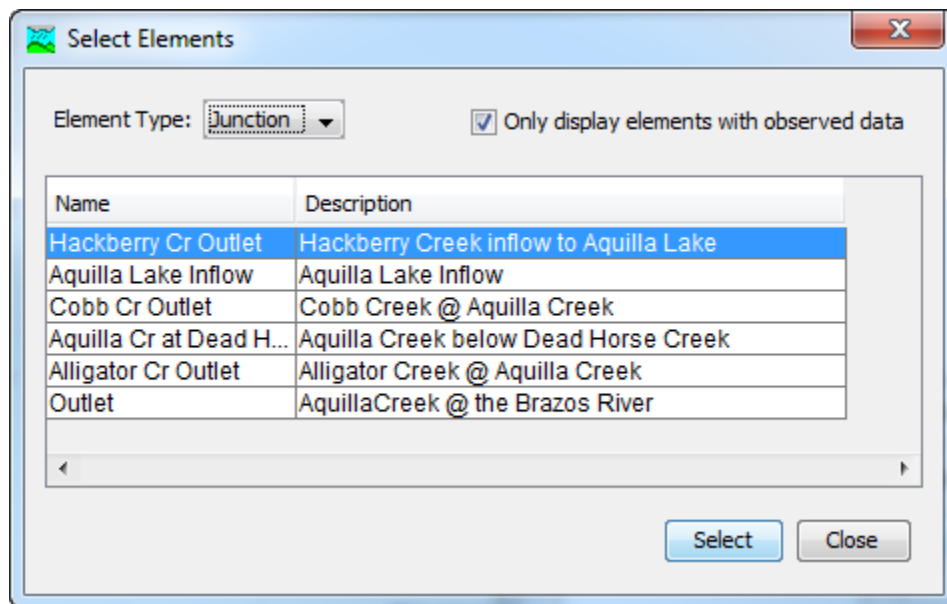

Figure 110. Selecting elements to be computation points. The element type is set to show only junctions, and the observed data option limits the elements to those with observed flow, observed stage, or another type of observed data.

## Unselecting Computation Points

There are two ways to unselect an element so that it is no longer a computation point. The first way is to click on the element in the *Basin Model Map* window using the right mouse button (Figure 111). Choose the **Unselect Computation Point** command to indicate the element will no longer be a computation point. It is only possible to unselect the element if it is already selected as a computation point. The small red circle added to the element icon in the *Basin Model Map* window and also in the *Watershed Explorer* will be removed to indicate the element is no longer a computation point.

The second way to unselect an element as a computation point is by using the *Computation Point Manager* window (Figure 112). To access the manager, click on the **Parameters** menu and choose the **Computation Point Manager** command. The manager shows all of the elements that have been selected as computation points. Select the element that will discontinue as a computation point; the selected element is highlighted in the list. Press the **Unselect Element** button to undesignate the selected element as a computation point.

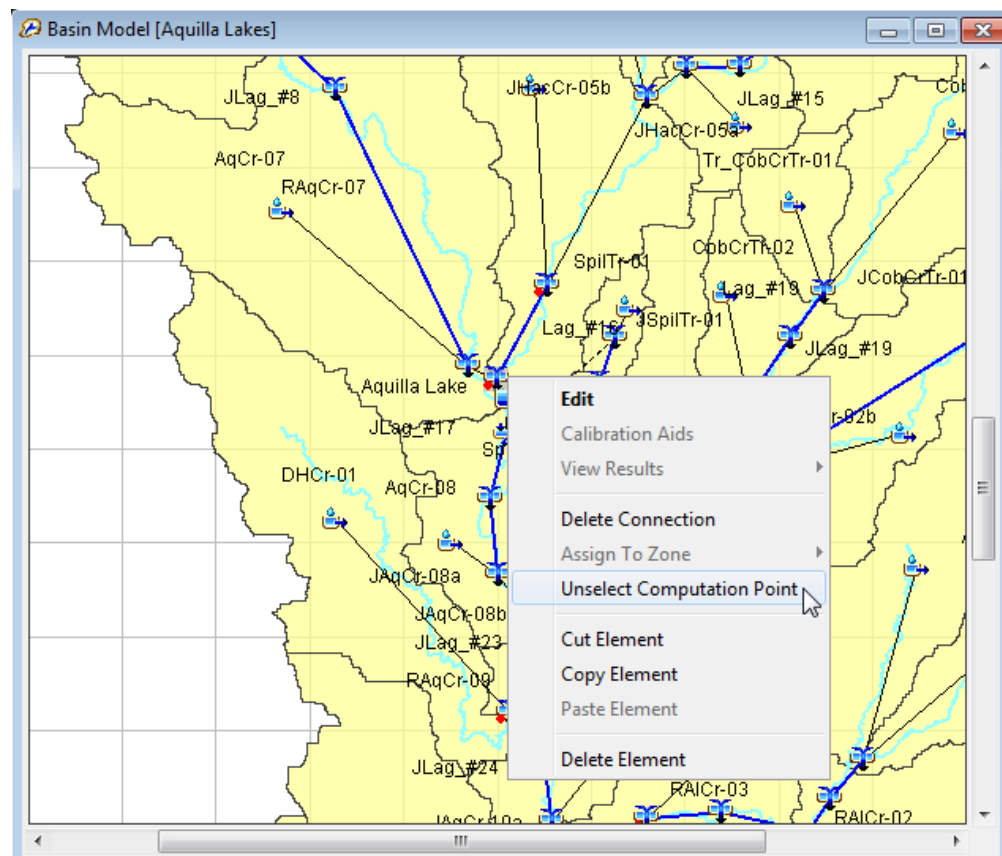

Figure 111. Setting a junction to no longer be a computation point by right-clicking in the basin model map.

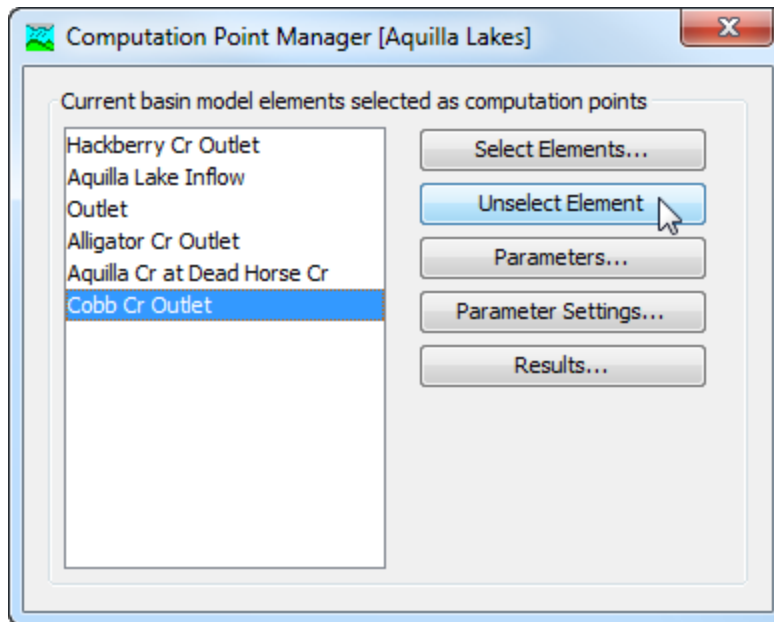

Figure 112. Unselecting an element as a computation point using the computation point manager.

### Selecting Calibration Parameters

Each computation point includes a customizable editor to aid in calibration of a simulation run. The editor can be customized by selecting the parameters it will contain. The parameters selected for the editor must be in the elements upstream of the computation point. If the computation point is a subbasin or reach element, then parameters at that element may also be selected. If there is an upstream computation point, then the selected parameters must be at elements between the two computation points. Parameters selected at one computation point will be automatically transferred if a new computation point is selected upstream.

The process of selecting parameters for the customizable editor at a computation point begins on the *Computation Point Manager* window (Figure 113). To access the manager, click on the **Parameters** menu and choose the **Computation Point Manager** command. The manager shows all of the elements that have been selected as computation points. Select the computation point where you wish to add parameters; the selected computation point is highlighted in the list. Press the **Parameters...** button open the parameter management window (Figure 114) and then press the **Select...** button to begin selecting the parameters for the computation point.

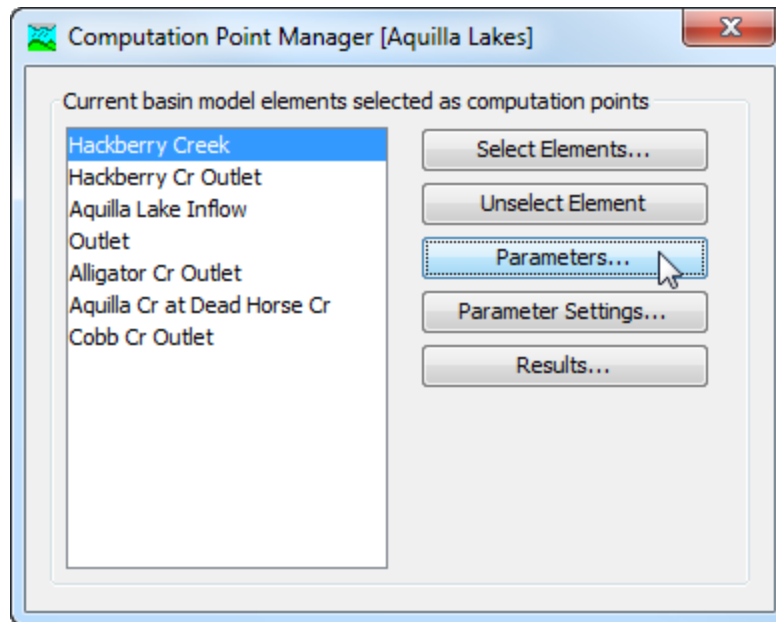

Figure 113. Preparing to select parameters for the customizable editor at the "Hackberry Creek" computation point.

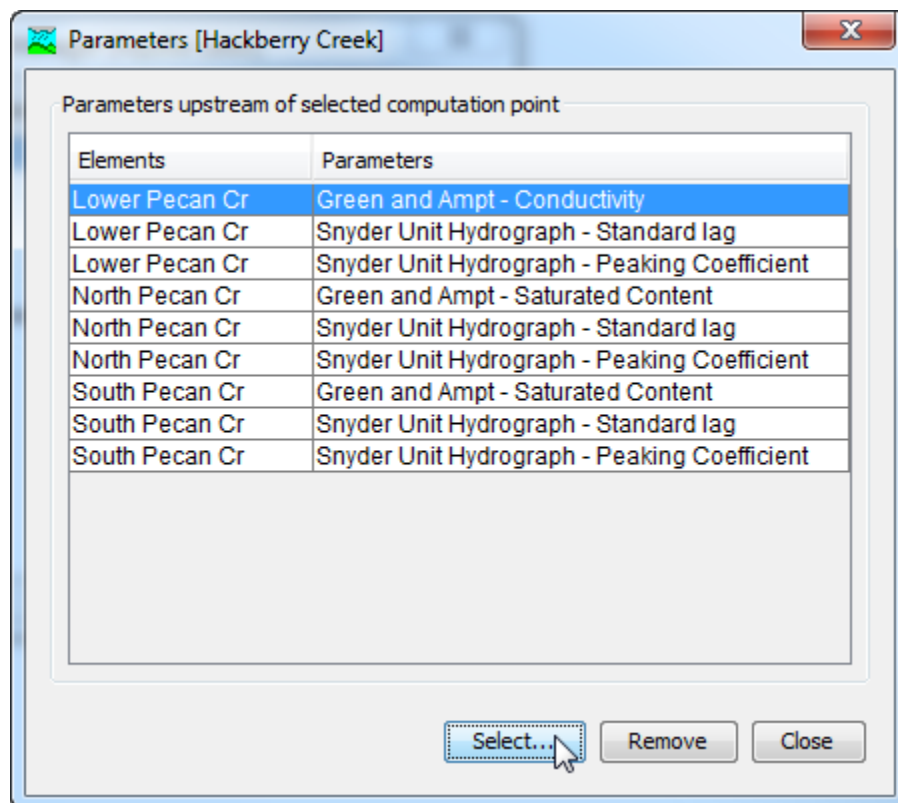

Figure 114. The parameters management window shows all the parameters for a computation point selected in the Computation Point Manager.



The *Select Parameters* window is used to choose the parameters to add to a computation point. Each of the subbasin and reach elements upstream of the computation point are shown in a list on the left side of the window. The element selected as the computation point is also shown in the list if the element is a subbasin or reach. Click on an element in the list on the left side of the window; the selected element is highlighted. The right side of the window will be updated to show all of the parameters at the selected element that can be chosen for the customizable editor (Figure 115). More than one parameter can be selected simultaneously by holding the control key and clicking on several parameters. Press the **Select** button when you have selected the parameters you wish to add. Selected parameters are removed from the list of available parameters. You can choose parameters from additional elements by clicking on each element in the list on the left side of the window and selecting parameters from that element. When you are finished selecting parameters for the computation point, press the **Close** button to return to the *Parameters* window.

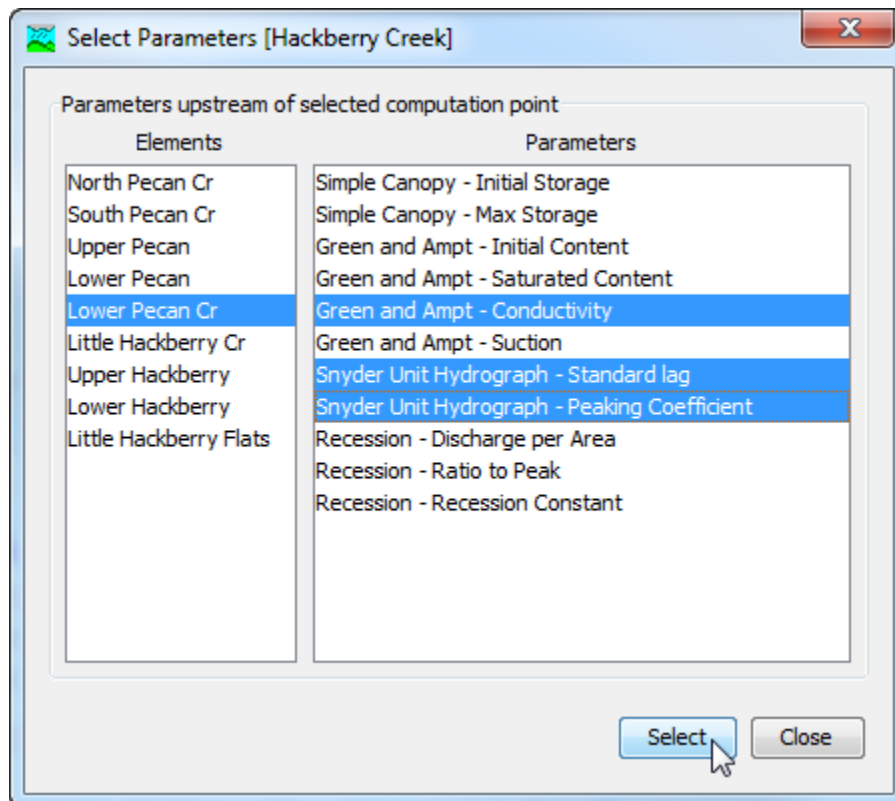

Figure 115. Selecting parameters for a computation point from those available at a subbasin element. Hold the control key and click with the mouse to select multiple parameters simultaneously.

## ***Unselecting Calibration Parameters***

Begin unselecting parameters from the customizable editor at a computation point using the the *Computation Point Manager* window (Figure 113). To access the manager, click on the **Parameters** menu and choose the **Computation Point Manager** command. The manager shows all of the elements that have been selected as computation points. Select the computation point where you wish to remove parameters; the selected computation point is highlighted in the list. Press the **Parameters..** button to begin removing parameters from the computation point.

The *Parameters* window shows all parameters that have been selected at the computation point. The left column in the table shows the name of the element and the right column in the table shows the parameter. The parameter is specified with the name of the method followed by the name of the parameter. In the example shown in Figure 116, the first row in the table represents the "Conductivity" parameter in the "Green Ampt" loss rate method of subbasin "Lower Pecan Cr." Click a row in the table to select it; the selected row is highlighted. Press the **Remove** button to remove the parameter from the computation point. You may unselect more than one parameter at a time by holding the control key and clicking on multiple rows in the table. Press the **Close** button when you have finished unselecting parameters and you will return to the *Computation Point Manager* window.

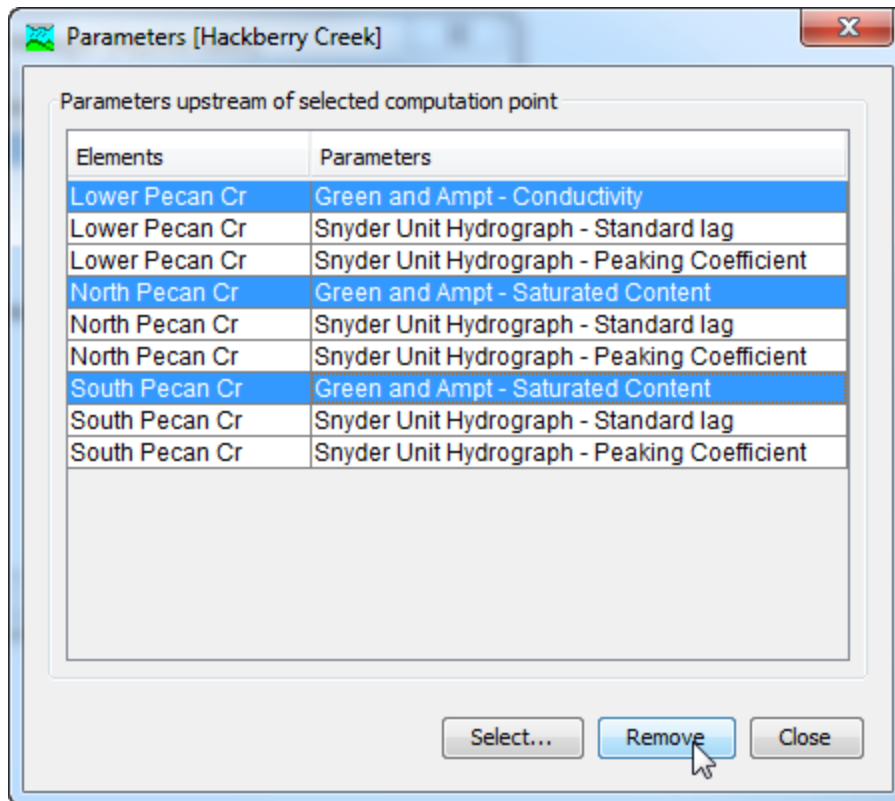

Figure 116. Unselecting parameters from a computation point. Hold the control key to select multiple parameters to be unselected.

## Settings for Calibration Parameters

The parameters in the customizable editor are represented with slider bars. The slider can be used to quickly change each parameter value in the range from a minimum value to a maximum value. By default the minimum and maximum values cover a very wide range. You can change the minimum and maximum values for each parameter to narrow the adjustment range to be suitable for a particular subbasin or reach in a watershed.

Change parameter settings for the customizable editor at a computation point using the *Computation Point Manager* window (Figure 113). To access the manager, click on the **Parameters** menu and choose the **Computation Point Manager** command. The manager shows all of the elements that have been selected as computation points. Select the computation point where you wish to make the parameter settings; the selected computation point is highlighted in the list. Press the **Parameter Settings** button to begin editing the parameter settings for the computation point.

The *Parameter Settings* window shows all of the parameters selected at a computation point. Each row in the table displays settings information for one parameter. The first column specifies the name of the element. The second column specifies the name of the method followed by the name of the parameter. The third column specifies the units of the parameter. In the example shown in Figure 117, the first row in the table represents the "Standard Lag" parameter in the "Snyder" transform method of subbasin "Lower Pecan Cr." The units of the parameter are "HR" which represents hours. You may specify the minimum and maximum value for the parameter in the final two columns of the table. While the parameter may take on values less than the minimum or greater than the maximum, the slider bar in the customizable editor for the computation point will only be able to adjust the parameter value within the range specified in the table.

Elements	Parameters	Units	Minimum	Maximum
Lower Pecan Cr	Green and Ampt - Conductivity	MM/HR	0.0100	250.0000
Lower Pecan Cr	Snyder Unit Hydrograph - Standard lag	HR	3.75	6.25
Lower Pecan Cr	Snyder Unit Hydrograph - Peaking Coefficient		0.25	0.50
North Pecan Cr	Green and Ampt - Saturated Content		0.0010	0.6000
North Pecan Cr	Snyder Unit Hydrograph - Standard lag	HR	4.50	7.50
North Pecan Cr	Snyder Unit Hydrograph - Peaking Coefficient		0.30	0.50
South Pecan Cr	Green and Ampt - Saturated Content		0.0010	0.6000
South Pecan Cr	Snyder Unit Hydrograph - Standard lag	HR	5.25	8.75
South Pecan Cr	Snyder Unit Hydrograph - Peaking Coefficient		0.30	0.50

Figure 117. Changing the minimum and maximum parameter values in the customizable editor at a computation point.

## Computation Point Results

A computation point may optionally include up to five customized result graphs. You may specify which time-series results appear in each graph. The results selected for a graph must be in the elements upstream of the computation point, or at the computation point itself. If there is an upstream computation point, then the selected parameters must be at elements between the two computation points. Any of the various time-series computed at an element may be included in a graph. The results in the graphs will automatically update as soon as adjustments are made to parameter values using the customizable editor at the computation point.

Configure results at a computation point using the the *Computation Point Manager* window (Figure 113). To access the manager, click on the **Parameters** menu and choose the **Computation Point Manager** command. The manager shows all of the elements that have been selected as computation points. Select the computation point where you wish to configure result graphs; the selected computation point is highlighted in the list. Press the **Results** button to begin configuring the results for the computation point. The *Results* window opens and allows you to configure the results for up to five graphs (Figure 118). The selector in the upper left allows you to choose which graph to configure; you may select any of the five graphs. The table in the center of the window shows all of the results for the selected graph. The element name and the result name are shown for each result added to the graph.

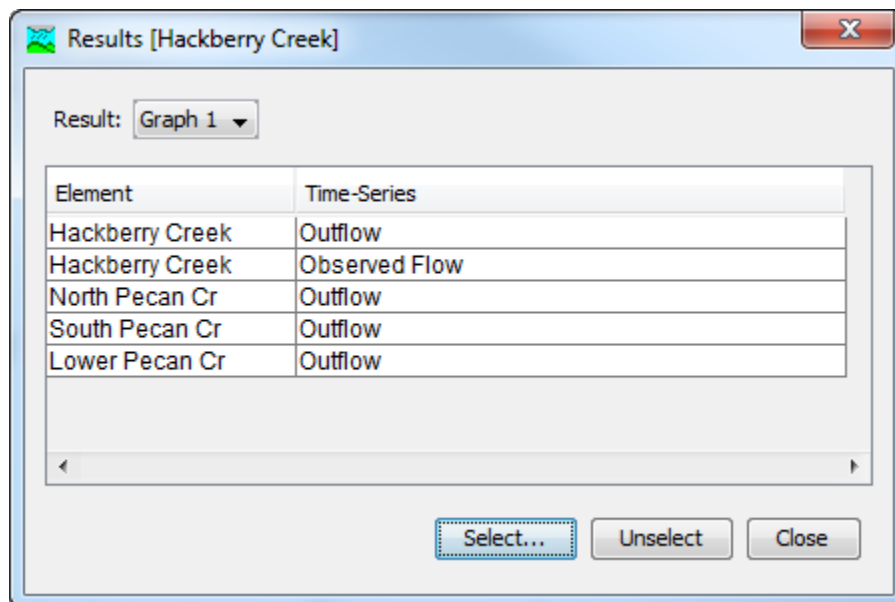
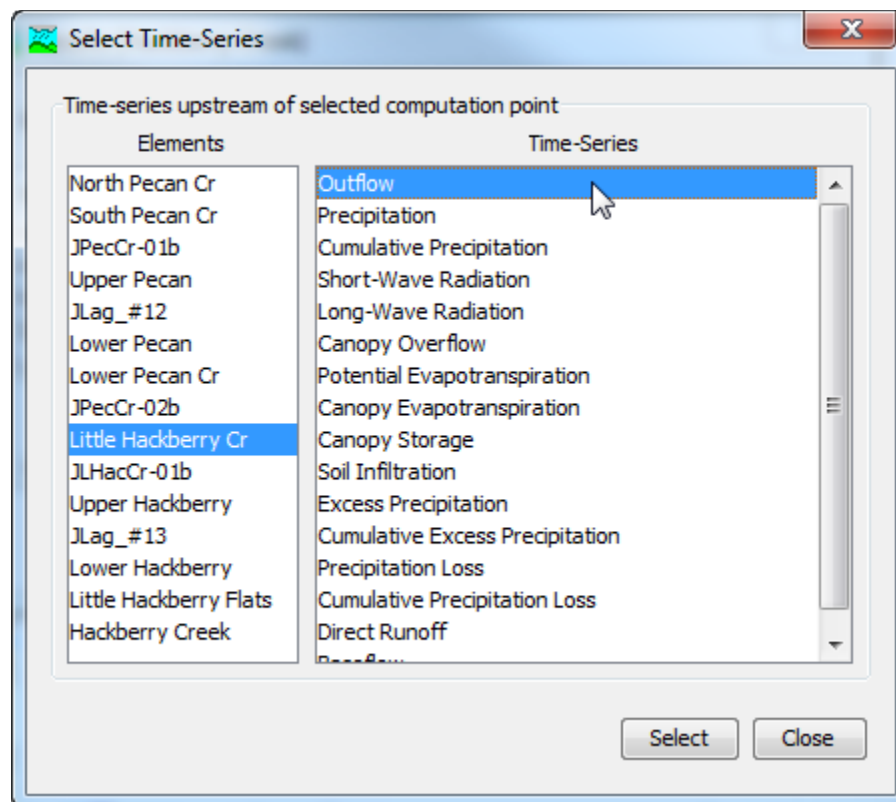

Figure 118. Selected results for the first graph at computation point "Hackberry Creek." The outflow and observed flow are included from the computation point, plus the outflow from several upstream subbasins.

Add a result to a graph by pressing the **Select** button in the *Results* window. The *Select Time-Series* window opens for choosing one or more results to add to the current graph selection (Figure 119). The left side of the window shows the computation point element and all elements upstream of it. Select the element that produces the result that you wish to add to the graph. Select the element by clicking on it with the mouse; the selected element is highlighted in the list. Only one element can be selected at a time. All of the available time-series for the selected element are shown on the right side. Select the time-series result you wish to add to the graph by clicking on it and then pressing the **Select** button. You can add multiple time-series results

simultaneously by holding the control key and clicking on more than one result. All selected time-series are added to the graph when the **Select** button is pressed. Time-series results are not shown in the list if they have already been added to the graph. Press the **Close** button when you are done selecting results and wish to return to the *Results* window.

Remove a selected time-series result from a graph directly on the *Results* window (Figure 120). Select the result you wish to remove by clicking it with the mouse; the selected result is highlighted in the list. You may select multiple results simultaneously by holding the control key and clicking additional results. Press the **Unselect** button to remove the time-series results from the current graph selection.



*Figure 119. Selecting the outflow time-series from a subbasin element for addition to a result graph at a computation point. Multiple time-series can be selected simultaneously by holding the control key and selecting additional time-series results.*

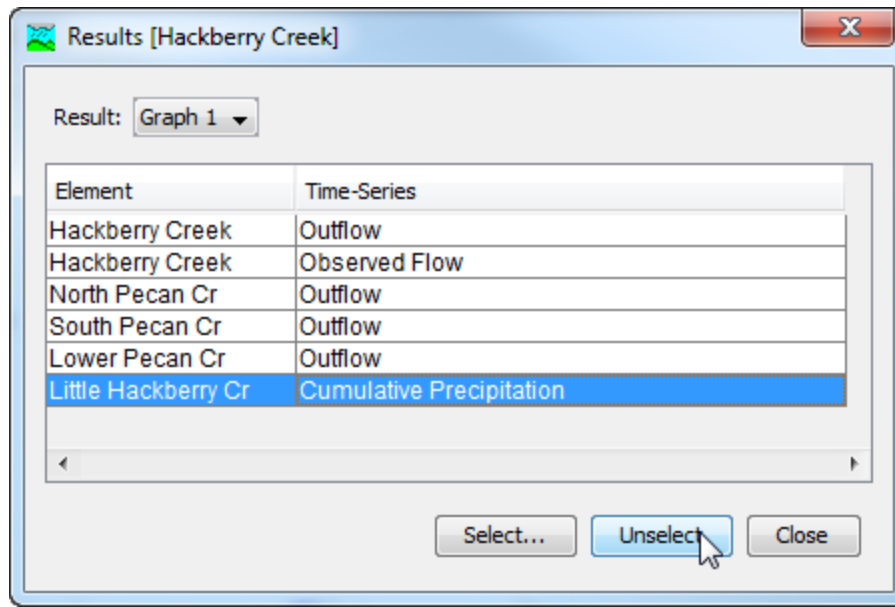

Figure 120. Removing a time-series result from a graph at a computation point.

## References

Autodesk, Inc. 2005. "AutoCAD 2006 Customization Guidebook." San Rafael, CA.

Barnes Jr., Harry H. 1967. "Roughness Characteristics of Natural Channels." U.S. Geological Survey, Denver, CO.

Environmental Systems Research Institute, Inc. July 1998. "ESRI Shapefile Technical Description." Redlands, CA.

U.S. Geological Survey. September 1999. "Standards for Digital Line Graphs: Part 2 Specifications." Department of the Interior, Washington, DC.

This Page Left Blank



## CHAPTER 7

# Subbasin Elements

A subbasin is an element that usually has no inflow and only one outflow. It is one of only two ways to produce flow in the basin model. Outflow is computed from meteorologic data by subtracting losses, transforming excess precipitation, and adding baseflow. Optionally the user can choose to include a canopy component to represent interception and evapotranspiration. It is also optional to include a surface component to represent water caught in surface depressional storage. The subbasin can be used to model a wide range of catchment sizes.

### Selecting a Canopy Method

The canopy is one of the components that can be included in the subbasin element and can represent the presence of plants in the landscape. Plants intercept precipitation, reducing the amount of precipitation that arrives at the ground surface. Intercepted water evaporates between storm events. Plants also extract water from the soil in a process called transpiration. Evaporation and transpiration are often combined as evapo-transpiration. Selecting a canopy method is optional but should be used for continuous simulation applications.

Figure 121. Subbasin component editor. All element editors include the basin model and element names, description, and downstream connection.

The canopy method for a subbasin is selected on the *Component Editor* for the subbasin element (Figure 121). Access the *Component Editor* by clicking the subbasin element icon on the "Components" tab of the *Watershed Explorer*. You can also access the *Component Editor* by clicking on the element icon in the basin map, if the map is currently open. You can select a canopy method from the list of four available choices. If you choose the `NONE` method, the subbasin will not compute any interception or evapo-transpiration and all precipitation will be assumed as direct precipitation on the ground surface, and subject to interception by the surface, and infiltration into the soil. Use the selection list to choose the method you wish to use. Each subbasin may use a different method or several subbasins may use the same method.

When a new subbasin is created, it is automatically set to use the default canopy method specified in the program settings. You may change the canopy method for a subbasin at any time using the *Component Editor* for the subbasin element. Since a subbasin can only use one canopy method at a time, you will be warned when changing methods that the old parameter data will be lost. You can turn off this warning in the program settings. You can change the canopy method for several subbasins simultaneously. Click on the **Parameters** menu and select the **Canopy ⇒ Change Method** command. The canopy method you choose will be applied to the selected subbasins in the basin model, or to all subbasins if none are currently selected.

The parameters for each canopy method are presented on a separate *Component Editor* from the subbasin element editor. The "Canopy" editor is always shown next to the "Subbasin" editor. If the kinematic wave transform method is selected, there may be two canopy editors, one for each runoff plane. The information shown on the canopy editor will depend on which method is currently selected.

### ***Dynamic Canopy***

This method includes an interception storage capacity and a crop coefficient that change in time. The storage capacity specifies the amount of water that can be held in the canopy before precipitation begins falling through to the ground surface. No through-fall will occur until the canopy storage is full. The canopy will use all potential evapo-transpiration until the storage is emptied. The potential evapotranspiration is multiplied by the crop coefficient to determine the amount of evapotranspiration from canopy storage and later the surface and soil components. Only after the canopy storage has been emptied will unused potential evapotranspiration be used by the

surface and soil components. The *Component Editor* is shown in Figure 122.

The initial condition of the canopy should be specified as the percentage of the canopy storage that is full of water at the beginning of the simulation.

There is currently only one method for specifying the storage capacity of the canopy. The storage is specified as a fixed effective depth of water that can be held in the canopy before additional precipitation falls through to the ground surface. The storage depth does not change for the duration of the simulation.

There are two methods for specifying the crop coefficient. A time-series may be used to specify how the crop coefficient changes during the plant growing season. The coefficient must be defined as a gage in the gage manager before it can be selected. You may use a chooser to select the gage by pressing the gage button next to the selection list. You will not be able to select a gage if no gages have been created in the time-series data manager. Alternately, a grid may be used to specify how the crop coefficient changes at each grid cell during the growing season. The crop coefficient grid must be selected from the grids that have been previously defined in the grid data manager.

The canopy can be set to only evaporate water from storage and extract water from the soil during dry time periods with no precipitation. Version 4.1 of the program and all previous versions only performed evapotranspiration calculations during dry periods. Alternately the canopy can be set to evaporate water from storage and extract water from the soil during both dry and wet periods. The choice for simultaneous precipitation and evapotranspiration can improve results when using a long time interval or during a snowmelt simulation.

There are two methods for extraction of water from the soil. The `Simple` method extracts water at the potential evapo-transpiration rate, and can be used with the deficit constant or soil moisture accounting loss rate methods. The `Tension Reduction` method extracts water at the potential evapo-transpiration rate from the gravity zone but reduces the rate when extracting from the tension zone; it can only be used with the soil moisture accounting loss rate method.

Subbasin Canopy Loss Transform Baseflow Options

**Basin Name: Alt Post Dam**  
**Element Name: Deer Cr**

\*Initial Storage (%) 0

Storage Method: Fixed

\*Max Storage (MM) 5.1

Crop Method: Time-Series Gage

Crop Gage: Hardwood Grow Season

Evapotranspiration: Only Dry Periods

Uptake Method: Tension Reduction

Figure 122. Dynamic canopy method editor.

### Gridded Simple Canopy

This method implements the simple canopy method on a grid cell basis. Each grid cell has separate parameter values, and separate precipitation. The *Component Editor* is shown in Figure 123.

The initial condition of the canopy should be specified as the percentage of the canopy storage that is full of water at the beginning of the simulation. The same percentage will be applied to every grid cell.

The canopy storage grid must be selected from the grids that have been previously defined in the grid data manager. The grid should specify the maximum canopy storage in each grid cell; the storage is constant for the duration of a simulation. You may use a chooser to select the grid by pressing the grid button next to the selection list. You will not be able to select a grid if no grids have been created in the grid data manager.

The crop coefficient grid must be selected from the grids that have been previously defined in the grid data manager. The grid should specify the ratio of the potential evapo-transpiration computed in the meteorologic model that should be applied in each grid cell; the coefficient is constant for the duration of a simulation. You may use a chooser to select the grid by pressing the grid button next to the selection list. You will not be able to select a grid if no grids have been created in the grid data manager.

Figure 123. Gridded simple canopy method editor.

The canopy can be set to only evaporate water from storage and extract water from the soil during dry time periods with no precipitation. Version 4.1 of the program and all previous versions only performed evapotranspiration calculations during dry periods. Alternately the canopy can be set to evaporate water from storage and extract water from the soil during both dry and wet periods. The choice for simultaneous precipitation and evapotranspiration can improve results when using a long time interval or during a snowmelt simulation.

There are two methods for extraction of water from the soil. The `Simple` method extracts water at the potential evapo-transpiration rate, and can be used with the deficit constant or soil moisture accounting loss rate methods. The `Tension Reduction` method extracts water at the potential evapo-transpiration rate from the gravity zone but reduces the rate when extracting from the tension zone; it can only be used with the soil moisture accounting loss rate method.

### **Simple Canopy**

This method is a simple representation of a plant canopy. All precipitation is intercepted until the canopy storage capacity is filled. Once the storage is filled, all further precipitation falls to the surface, or directly to the soil if no representation of the surface is included. All potential evapotranspiration will be used to empty the canopy storage until the water in storage has been eliminated. The potential evapotranspiration is multiplied by the crop coefficient to determine the amount of evapotranspiration from canopy storage and later the surface and soil components. Only after the canopy storage has been emptied will unused potential evapotranspiration be used by the surface and soil components. The *Component Editor* is shown in Figure 124.

The initial condition of the canopy should be specified as the percentage of the canopy storage that is full of water at the beginning of the simulation.

Canopy storage represents the maximum amount of water that can be held on leaves before through-fall to the surface begins. The amount of storage is specified as an effective depth of water.

The crop coefficient is a ratio applied to the potential evapotranspiration (computed in the meteorologic model) when computing the amount of water to actually extract from the soil.

The canopy can be set to only evaporate water from storage and extract water from the soil during dry time periods with no precipitation. Version 4.1 of the program and all previous versions only performed evapotranspiration calculations during dry periods. Alternately the canopy can be set to evaporate water from storage and extract water from the soil during both dry and wet periods. The choice for simultaneous precipitation and evapotranspiration can improve results when using a long time interval or during a snowmelt simulation.

There are two methods for extraction of water from the soil. The `Simple` method extracts water at the potential evapotranspiration rate, and can be used with the deficit constant or soil moisture accounting loss rate methods. The `Tension Reduction` method can be used with the soil moisture accounting method and extracts water at the potential evapotranspiration rate from the gravity zone but reduces the rate when extracting from the tension zone. No water is extracted from the soil unless the `Simple` or `Tension Reduction` method is selected

Basin Name: Alt Post Dam	
Element Name: Deer Cr	
*Initial Storage (%)	0
*Max Storage (MM)	5.1
Crop Coefficient:	1.0
Evapotranspiration:	Wet and Dry Periods
Uptake Method:	Simple

Figure 124. Simple canopy method editor.

## Selecting a Surface Method

The surface is one of the components that can be included in the subbasin element. It is intended to represent the ground surface where water may accumulate in surface depressional storage. The depression storage of an impervious surface such as a parking lot is generally close to zero. However, the depression storage for an agricultural field can be quite large if conservation tillage practices are

used. Precipitation through-fall from the canopy, or direct precipitation if there is no canopy, impacts on the surface. The net precipitation accumulates in the depression storage and infiltrates as the soil has capacity to accept water. Surface runoff will begin when the precipitation rate exceeds the infiltration rate, and the surface storage is filled. Precipitation residing in the surface storage can infiltrate after precipitation stops and is subject to potential evapo-transpiration. Selecting a surface method is optional and generally only used for continuous simulation applications.

The surface method for a subbasin is selected on the *Component Editor* for the subbasin element (Figure 121). Access the *Component Editor* by clicking the subbasin element icon on the "Components" tab of the *Watershed Explorer*. You can also access the *Component Editor* by clicking on the element icon in the basin map, if the map is currently open. You can select a surface method from the list of three available choices. If you choose the `NONE` method, the subbasin will not compute any surface depression storage and all through-fall precipitation will be assumed as direct precipitation on the ground surface, and subject to infiltration into the soil. Use the selection list to choose the method you wish to use. Each subbasin may use a different method or several subbasins may use the same method.

When a new subbasin is created, it is automatically set to use the default surface method specified in the program settings. You may change the surface method for a subbasin at any time using the *Component Editor* for the subbasin element. Since a subbasin can only use one surface method at a time, you will be warned when changing methods that the old parameter data will be lost. You can turn off this warning in the program settings. You can change the surface method for several subbasins simultaneously. Click on the **Parameters** menu and select the **Surface ⇒ Change Method** command. The surface method you choose will be applied to the selected subbasins in the basin model, or to all subbasins if none are currently selected.

The parameters for each surface method are presented on a separate *Component Editor* from the subbasin element editor. The "Surface" editor is always shown next to the "Canopy" editor. If the kinematic wave transform method is selected, there may be two surface editors, one for each runoff plane. The information shown on the surface editor will depend on which method is currently selected.

## Gridded Simple Surface

This method implements the simple surface method on a grid cell basis. Each grid cell has separate parameter values, and separate precipitation through-fall. The *Component Editor* is shown in Figure 125.

The initial condition of the surface should be specified as the percentage of the surface storage that is full of water at the beginning of the simulation. The same percentage will be applied to every grid cell.

The surface storage grid must be selected from the grids that have been previously defined in the grid data manager. The grid should specify the maximum surface storage in each grid cell. You may use a chooser to select the grid by pressing the grid button next to the selection list. You will not be able to select a grid if no grids have been created in the grid data manager.

Figure 125. Gridded simple surface method editor.

## Simple Surface

This method is a simple representation of the soil surface. All precipitation or precipitation through-fall that arrives on the soil surface is captured in storage until the storage capacity of the surface is filled. Water in surface storage infiltrates into the soil whenever it is present in storage. That is, water will infiltrate even when the storage capacity is not full. Surface runoff will be generated when the storage capacity is filled, and the precipitation through-fall rate exceeds the infiltration rate. The *Component Editor* is shown in Figure 126.

The initial condition of the surface should be specified as the percentage of the surface storage that is full of water at the beginning of the simulation.

Surface storage represents the maximum amount of water that can be held on the soil surface before surface runoff begins. The amount of storage is specified as an effective depth of water.



Loss	Transform	Baseflow	Options
 Subbasin	Canopy		Surface
<p><b>Basin Name: Alt Post Dam</b></p> <p><b>Element Name: Deer Cr</b></p> <p>*Initial Storage (%) <input type="text" value="0"/></p> <p>*Max Storage (MM) <input type="text" value="16"/></p>			

Figure 126. Simple surface method editor.

## Selecting a Loss Method

While a subbasin element conceptually represents infiltration, surface runoff, and subsurface processes interacting together, the actual infiltration calculations are performed by a loss method contained within the subbasin. A total of twelve different loss methods are provided. Some of the methods are designed primarily for simulating events while others are intended for continuous simulation. All of the methods conserve mass. That is, the sum of infiltration and precipitation left on the surface will always be equal to total incoming precipitation.

The loss method for a subbasin is selected on the *Component Editor* for the subbasin element. Access the *Component Editor* by clicking the subbasin element icon on the "Components" tab of the *Watershed Explorer* (Figure 121). You can also access the *Component Editor* by clicking on the element icon in the basin map, if the map is currently open. You can select a loss method from the list of twelve available choices. If you choose the `None` method, the subbasin will not compute infiltration and all precipitation will be assumed as excess and subject to surface storage and runoff. Use the selection list to choose the method you wish to use. Each subbasin may use a different method or several subbasins may use the same method.

When a new subbasin is created, it is automatically set to use the default loss method specified in the program settings. You may change the loss method for a subbasin at any time using the *Component Editor* for the subbasin element. Since a subbasin can only use one loss method at a time, you will be warned when changing methods that the old parameter data will be lost. You can turn off this warning in the program settings. You can change the loss method for several subbasins simultaneously. Click on the **Parameters** menu and select the **Loss ⇒ Change Method** command. The loss method you choose will be applied to the selected subbasins in the basin model, or to all subbasins if none are currently selected.

The parameters for each loss method are presented on a separate *Component Editor* from the subbasin element editor. The "Loss" editor is always shown next to the "Surface" editor. If the kinematic wave transform method is selected, there may be two loss editors, one for each runoff plane. The information shown on the loss editor will depend on which method is currently selected.

### **Deficit and Constant Loss**

The deficit constant loss method uses a single soil layer to account for continuous changes in moisture content. It should be used in combination with a canopy method that will extract water from the soil in response to potential evapo-transpiration computed in the meteorologic model. The soil layer will dry out between precipitation events as the canopy extracts soil water. There will be no soil water extraction unless a canopy method is selected. Percolation out the bottom of the layer only occurs when the soil layer is saturated. The *Component Editor* is shown in Figure 127.

Element Name: Deer Cr	
*Initial Deficit (IN)	3.2
*Maximum Deficit (IN)	5.4
*Constant Rate (IN/HR)	0.23
*Impervious (%)	5

Figure 127. Deficit constant loss method editor.

The initial deficit is the initial condition for the method. It is the amount of water required to fill the soil layer to the maximum storage.

The maximum deficit specifies the amount of water the soil layer can hold, specified as a depth. An upper bound is the depth of the active soil layer multiplied by the porosity. However, in most cases such an estimate must be reduced by the permanent wilting point and for other conditions that reduce the water holding capacity.

The constant rate defines the percolation rate when the soil layer is saturated. Saturated hydraulic conductivity is a good approximation.

The percentage of the subbasin which is directly connected impervious area can be specified. No loss calculations are carried out on the impervious area; all precipitation on that portion of the subbasin becomes excess precipitation and subject to surface storage and direct runoff.

## Exponential Loss

The exponential loss method is empirical and generally speaking should not be used without calibration. It represents incremental infiltration as a logarithmically decreasing function of accumulated infiltration. It includes the option for increased initial infiltration when the soil is particularly dry before the arrival of a storm. It should not be used for continuous simulation because it is a function of cumulative infiltration and does not include any type of recovery. The *Component Editor* is shown in Figure 128.

The initial range is the amount of initial accumulated infiltration during which the loss rate is increased. This parameter is considered to be a function primarily of antecedent soil moisture deficiency and is usually storm-dependent.

The initial coefficient specifies the starting loss rate coefficient on the exponential infiltration curve. It is assumed to be a function of infiltration characteristics and consequently may be correlated with soil type, land use, vegetation cover, and other properties of a subbasin.

Basin Name: Post Dam	
Element Name: Deer Cr	
*Initial Range (IN)	0.0
*Initial Coef ((IN/HR) <sup>(1-x)</sup> )	0.24
*Coef Ratio:	1.0
*Exponent:	0.7
*Impervious (%)	8

Figure 128. Exponential loss method editor.

The coefficient ratio indicates the rate at which the exponential decrease in infiltration capability proceeds. It may be considered a function of the ability of the surface of a subbasin to absorb precipitation and should be reasonably constant for large, homogeneous areas.

The precipitation exponent reflects the influence of precipitation rate on subbasin-average loss characteristics. It reflects the manner in which storms occur within an area and may be considered a characteristic of a particular region. It varies from 0.0 up to 1.0.

The percentage of the subbasin which is directly connected impervious area can be specified. No loss calculations are carried out on the

impervious area; all precipitation on that portion of the subbasin becomes excess precipitation and subject to direct runoff.

### **Green and Ampt Loss**

The Green and Ampt infiltration method is essentially a simplification of the comprehensive Richard's equation for unsteady water flow in soil. The Green and Ampt method assumes the soil is initially at uniform moisture content, and infiltration takes place with so-called piston displacement. The method automatically accounts for ponding at the soil-air interface. The *Component Editor* is shown in Figure 129.

The initial water content gives the initial saturation of the soil at the beginning of a simulation. It should be specified in terms of volume ratio.

Basin Name: Alt Post Dam	
Element Name: Deer Cr	
*Initial Content:	0.27
*Saturated Content:	0.48
*Suction (MM)	112
*Conductivity (MM/HR)	12.2
*Impervious (%)	0.0

Figure 129. Green Ampt loss method editor.

The saturated water content specifies the maximum water holding capacity in terms of volume ratio. It is often assumed to be the total porosity of the soil.

The wetting front suction must be specified. It is generally assumed to be a function of the soil texture.

The hydraulic conductivity must also be specified. It can be estimated from field tests or approximated by knowing the soil texture.

The percentage of the subbasin which is directly connected impervious area can be specified. No loss calculations are carried out on the impervious area; all precipitation on that portion of the subbasin becomes excess precipitation and subject to direct runoff.

### **Gridded Deficit Constant Loss**

The gridded deficit constant loss method essentially implements the deficit constant method on a grid cell by grid cell basis. Each grid cell receives separate precipitation and potential evapotranspiration from

the meteorologic model, while parameters are represented with grids from the grid data manager. A gridded canopy method should be selected that will extract water from the soil in response to potential evapo-transpiration computed in the meteorologic model. There will be no soil water extraction unless a canopy method is selected. The *Component Editor* is shown in Figure 130.

An initial deficit grid must be selected from the list of choices. The selection list will show all moisture deficit grids available in the grid data manager. You can use a chooser to select a grid by pressing the grid button next to the selection list. The chooser shows all of the moisture deficit grids in the grid data manager. Click on a grid to view the description. This is especially helpful since initial deficit and maximum storage grids are both stored as moisture deficit grids.

Figure 130. Gridded deficit constant loss method editor.

A maximum deficit grid must be selected from the list of choices. The selection list will show all moisture deficit grids available in the grid data manager. You can use a chooser to select a grid by pressing the grid button next to the selection list. The chooser shows all of the moisture deficit grids in the grid data manager. Click on a grid to view the description. This is especially helpful since initial deficit and maximum storage grids are both stored as moisture deficit grids.

A constant rate grid must be selected from the list of choices. The selection list will show all percolation rate grids available in the grid data manager. You can use the chooser to select a grid by pressing the grid button next to the selection list, or select directly from the list of choices.

An impervious grid must be selected from the list of choices. The selection list will show all impervious area grids available in the grid

data manager. You can use the chooser to select a grid by pressing the grid button next to the selection list.

The initial deficit grid ratio must be entered. The actual initial deficit value at each grid cell is obtained by multiplying the value obtained from the initial deficit grid by the specified ratio. The default value is 1.0.

The maximum deficit grid ratio must be entered. The actual maximum deficit value at each grid cell is obtained by multiplying the value obtained from the maximum deficit grid by the specified ratio. The default value is 1.0.

The constant rate grid ratio must be entered. The actual constant loss rate value at each grid cell is obtained by multiplying the value obtained from the constant rate grid by the specified ratio. The default value is 1.0.

The impervious grid ratio must be entered. The actual percentage of impervious area at each grid cell is obtained by multiplying the value obtained from the impervious grid by the specified ratio. The default value is 1.0.

### **Gridded Green and Ampt Loss**

The gridded Green and Ampt loss method essentially implements the Green and Ampt method on a grid cell by grid cell basis. Each grid cell receives separate precipitation from the meteorologic model. Parameters are represented with grids from the grid data manager. The *Component Editor* is shown in Figure 131.

The initial water content grid must be selected from the list of choices. The selection list will show all water content grids available in the grid data manager. You can use a chooser to select a grid by pressing the grid button next to the selection list. The chooser shows all of the water content grids in the grid data manager. Click on a grid to view the description. This is especially helpful since initial content and saturated content grids are both stored as water content grids. The saturated water content grid must be selected from the list of choices using these same procedures.

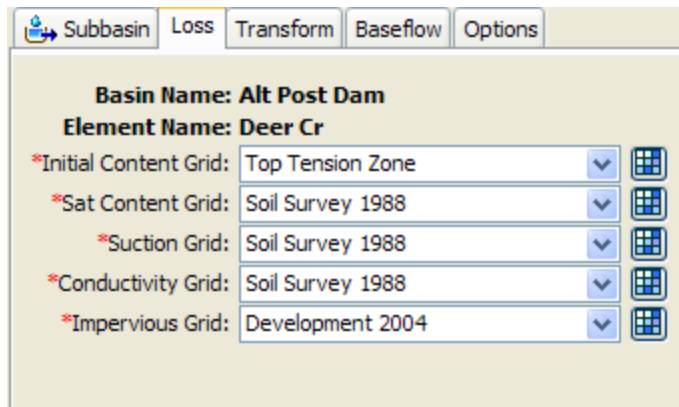

Figure 131. Gridded Green and Ampt loss rate component editor.

The wetting front suction grid must be selected from the list of choices. The selection list will show all of the water potential grids available in the grid data manager. You can use the chooser to select a grid by pressing the grid button next to the selection list.

The hydraulic conductivity grid must be selected from the list of choices. The selection list will show all of the percolation rate grids specified in the grid data manager, because conductivity is a type of percolation and has the same units. You can use the chooser to select a grid by pressing the grid button next to the selection list.

An impervious grid must be selected from the list of choices. The selection list will show all impervious area grids available in the grid data manager. You can use the chooser to select a grid by pressing the grid button next to the selection list.

### **Gridded SCS Curve Number Loss**

The gridded SCS curve number loss method essentially implements the Soil Conservation Service (SCS) curve number method on a grid cell by grid cell basis. Details of the curve number approach can be found in the National Engineering Handbook (NRCS, 2007). Each grid cell receives separate precipitation from the meteorologic model. All cells are initialized by scaling based on the curve number at each cell, and then allowed to evolve separately during the simulation based on individual precipitation inputs. The main parameter is represented with a grid from the grid data manager. The *Component Editor* is shown in Figure 132.

The curve number grid must be selected from the available choices. A curve number grid must be defined in the grid data manager before it can be used in the subbasin. You can use a chooser to select a grid by pressing the grid button next to the selection list. The chooser shows all of the curve number grids in the grid data manager.

The default initial abstraction ratio is 0.2 but may optionally be changed. The initial abstraction ratio is used to compute the initial abstraction at each grid cell. The potential retention is calculated from the curve number for each cell, then multiplied by the ratio to determine the actual initial abstraction for that cell.

The default potential retention scale factor is 1.0 but may optionally be changed. The potential retention scale factor is used to adjust the retention calculated from the curve number before it is multiplied by the initial abstraction ratio.

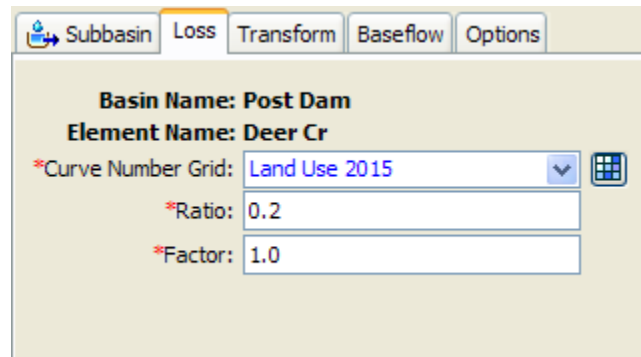

The screenshot shows a software interface with a tabbed menu at the top containing 'Subbasin', 'Loss', 'Transform', 'Baseflow', and 'Options'. The 'Loss' tab is active. Below the tabs, the following information is displayed:

- Basin Name: Post Dam
- Element Name: Deer Cr
- \*Curve Number Grid: Land Use 2015 (with a dropdown arrow and a grid icon)
- \*Ratio: 0.2
- \*Factor: 1.0

Figure 132. Gridded SCS curve number loss method editor.

### **Gridded Soil Moisture Accounting**

The gridded soil moisture accounting loss method essentially implements the soil moisture accounting method on a grid cell by grid cell basis. Each grid cell receives separate precipitation and potential evapotranspiration from the meteorologic model. All cells are initialized to the same initial conditions, and then allowed to evolve separately during the simulation based on individual precipitation inputs. Parameters are specified on a cell by cell basis using grids from the grid data manager. A gridded canopy method should be selected that will extract water from the soil in response to potential evapo-transpiration computed in the meteorologic model. There will be no soil water extraction unless a canopy method is selected. The *Component Editor* is shown in Figure 133.



Parameter	Value	Grid Selection
*Max Infiltration Grid:	Surface Influx Limit	Surface Influx Limit
*Initial Soil (%):	77	
*Soil Storage Grid:	Soil Storage (92 Survey)	Soil Storage (92 Survey)
*Tension Storage Grid:	Tension Storage (92 Survey)	Tension Storage (92 Survey)
*Soil Percolation Grid:	Soil Perc (92 Survey)	Soil Perc (92 Survey)
*Initial GW 1 (%):	65	
*GW 1 Storage Grid:	Upper GW	Upper GW
*GW 1 Percolation Grid:	Interflow Sept	Interflow Sept
*GW 1 Coefficient Grid:	Interflow	Interflow
*Initial GW 2 (%):	54	
*GW 2 Storage Grid:	Lower GW	Lower GW

Figure 133. Gridded soil moisture accounting loss method editor.

The maximum infiltration grid is selected from the percolation grids that have been previously defined in the grid data manager. The grid should specify the maximum infiltration rate at each grid cell. This is the upper bound on infiltration; the actual infiltration at any cell in a particular time interval is a linear function of the surface and soil storage in the cell, if a surface method is selected. Without a selected surface method, water will always infiltrate at the maximum rate. You may use a chooser to select the grid. The grid selections will be disabled unless you have previously created grids in the grid data manager. Likewise, you must also select a soil percolation and groundwater percolation grids. All infiltration and percolation grids use the same type of parameter grid so descriptions for the grids are important.

The initial condition of the soil should be specified as the percentage of the soil storage that is full of water at the beginning of the simulation. The same percentage will be applied to every grid cell. Likewise, you must specify the initial storage of each groundwater layer.

The soil storage grid must be selected from the grids that have been previously defined in the grid data manager. The grid should specify the maximum soil storage in each grid cell. You may use a chooser to select the grid by pressing the grid button next to the selection list. You will not be able to select a grid if no grids have been created in the grid data manager. Likewise, you must select a tension storage grid, and a storage grid for each groundwater layer. Because tension storage is contained within the total soil storage, the tension storage at each cell must be less than the soil storage at the same cell.

Groundwater coefficient grids must be selected for the upper and lower groundwater layers. The selected grid should specify the storage coefficient for each cell in the layer. The coefficient is used as the time lag on a linear reservoir for transforming water in storage to become lateral outflow. Contributions from each grid cell are accumulated to determine the total amount of flow available to become baseflow.

### **Initial and Constant Loss**

The initial constant loss method is very simple but still appropriate for watersheds that lack detailed soil information. It is also suitable for certain types of flow-frequency studies. The *Component Editor* is shown in Figure 134.

The initial loss specifies the amount of incoming precipitation that will be infiltrated or stored in the watershed before surface runoff begins. There is no recovery of the initial loss during periods without precipitation.

The constant rate determines the rate of infiltration that will occur after the initial loss is satisfied. The same rate is applied regardless of the length of the simulation.

The percentage of the subbasin which is directly connected impervious area can be specified. No loss calculations are carried out on the impervious area; all precipitation on that portion of the subbasin becomes excess precipitation and subject to direct runoff.

Basin Name: Post Dam	
Element Name: Deer Cr	
*Initial Loss (IN)	0.6
*Constant Rate (IN/HR)	0.19
*Impervious (%)	0.0

Figure 134. Initial and constant loss method editor.

### **SCS Curve Number Loss**

The Soil Conservation Service (SCS) curve number method implements the curve number methodology for incremental losses (NRCS, 2007). Originally, the methodology was intended to calculate total infiltration during a storm. The program computes incremental precipitation during a storm by recalculating the infiltration volume at the end of each time interval. Infiltration during each time interval is

the difference in volume at the end of two adjacent time intervals. The *Component Editor* is shown in Figure 135.

You may optionally enter an initial abstraction. The initial abstraction defines the amount of precipitation that must fall before surface excess results. However, it is not the same as an initial interception or initial loss since changing the initial abstraction changes the infiltration response later in the storm. If this value is left blank, it will be automatically calculated as 0.2 times the potential retention, which is calculated from the curve number.

You must enter a curve number. This should be a composite curve number that represents all of the different soil group and land use combinations in the subbasin. The composite curve number should not include any impervious area that will be specified separately as the percentage of impervious area.

The percentage of the subbasin which is directly connected impervious area can be specified. Any percentage specified should not be included in computing the composite curve number. No loss calculations are carried out on the impervious area; all precipitation on that portion of the subbasin becomes excess precipitation and subject to direct runoff.

Field	Value
Basin Name	Post Dam
Element Name	Deer Cr
Initial Abstraction (IN)	
*Curve Number	88
*Impervious (%)	0.0

Figure 135. SCS curve number loss method editor.

### **Smith Parlange Loss**

The Smith Parlange loss method approximates Richard's equation for infiltration into soil by assuming the wetting front can be represented with an exponential scaling of the saturated conductivity. This linearization approach allows the infiltration computations to proceed very quickly while maintaining a reasonable approximation of the wetting front. The *Component Editor* is shown in Figure 136.

Element Name: Deer Cr	
*Initial Content:	0.3
*Residual Content:	0.027
*Saturated Content:	0.463
*Bubbling Pressure (IN)	7.88
*Pore Distribution:	0.252
*Conductivity (IN/HR)	0.47
*Impervious (%)	0.0
Temperature Gage:	NCEP Temp
*Beta Zero (DEG F)	-682

Figure 136. Smith Parlange loss method editor.

The initial water content gives the initial saturation of the soil at the beginning of a simulation. It should be specified in terms of volume ratio.

The residual water content specifies the amount of water remaining in the soil after all drainage has ceased. It should be specified in terms of volume ratio. It may be determined in the laboratory or estimated from the soil texture.

The saturated water content specifies the maximum water holding capacity in terms of volume ratio. It is often assumed to be the total porosity of the soil.

The bubbling pressure, also known as the wetting front suction, must be specified. It is generally assumed to be a function of the soil texture.

The pore size distribution determines how the total pore space is distributed in different size classes. It is typically assumed to be a function of soil texture.

The hydraulic conductivity must also be specified, typically as the effective saturated conductivity. It can be estimated from field tests or approximated by knowing the soil texture.

The percentage of the subbasin which is directly connected impervious area can be specified. No loss calculations are carried out on the impervious area; all precipitation on that portion of the subbasin becomes excess precipitation and subject to direct runoff.

Optionally, a temperature gage may be selected for adjusting the water density, water viscosity, and matric potential based on temperature. If

no temperature gage is selected then a temperature of 25C (75F) is assumed to prevail. The gage must be defined in the time-series manager before it can be selected in the component editor.

The beta zero parameter is used to correct the matric potential based on temperature. It has been found to be a function of soil texture. It will only be shown for input if a temperature gage has been selected.

### **Soil Moisture Accounting Loss**

The soil moisture accounting loss method uses three layers to represent the dynamics of water movement in the soil. It should be used in conjunction with a canopy method and a surface method. The soil layer will dry out between precipitation events as the canopy extracts soil water. There will be no soil water extraction unless a canopy method is selected. The surface layer holds precipitation and allows it to infiltrate after the rain has stopped. Infiltration is generally reduced if no surface method is selected. Layers within the soil moisture accounting method include soil storage, upper groundwater, and lower groundwater. The soil layer is subdivided into tension storage and gravity storage. Groundwater layers are not designed to represent aquifer processes; they are intended to be used for representing shallow interflow processes. The method provides for wetting and recovery cycles and can be used for long periods of continuous simulation, so long as a canopy method is selected in order to compute evapo-transpiration. The *Component Editor* is shown in Figure 137.

Subbasin		Canopy	Surface
Loss	Transform	Baseflow	Options
<b>Basin Name: Alt Post Dam</b>			
<b>Element Name: Deer Cr</b>			
*Soil (%)	67		
*Groundwater 1 (%)	50		
*Groundwater 2 (%)	82		
*Max Infiltration (MM/HR)	53		
*Impervious (%)	0.0		
*Soil Storage (MM)	240		
*Tension Storage (MM)	206		
*Soil Percolation (MM/HR)	4		
*GW 1 Storage (MM)	250		
*GW 1 Percolation (MM/HR)	1.2		
*GW 1 Coefficient (HR)	120		

Figure 137. Soil moisture accounting loss method editor.

The initial condition of the soil should be specified as the percentage of the soil that is full of water at the beginning of the simulation. The initial condition of the upper and lower groundwater layers must also be specified.

The maximum infiltration rate sets the upper bound on infiltration from the surface storage into the soil. This is the upper bound on infiltration; the actual infiltration in a particular time interval is a linear function of the surface and soil storage, if a surface method is selected. Without a selected surface method, water will always infiltrate at the maximum rate.

The percentage of the subbasin which is directly connected impervious area can be specified. All precipitation on that portion of the subbasin becomes excess precipitation and subject to direct runoff.

Soil storage represents the total storage available in the soil layer. It may be zero if you wish to eliminate soil calculations and pass infiltrated water directly to groundwater.

Tension storage specifies the amount of water storage in the soil that does not drain under the affects of gravity. Percolation from the soil layer to the upper groundwater layer will occur whenever the current soil storage exceeds the tension storage. Water in tension storage is only removed by evapotranspiration. By definition, tension storage must be less that soil storage.

The soil percolation sets the upper bound on percolation from the soil storage into the upper groundwater. The actual percolation rate is a linear function of the current storage in the soil and the current storage in the upper groundwater.

Groundwater 1 storage represents the total storage in the upper groundwater layer. It may be zero if you wish to eliminate the upper groundwater layer and pass water percolated from the soil directly to the lower groundwater layer.

The groundwater 1 percolation rate sets the upper bound on percolation from the upper groundwater into the lower groundwater. The actual percolation rate is a linear function of the current storage in the upper and lower groundwater layers.

The groundwater 1 coefficient is used as the time lag on a linear reservoir for transforming water in storage to become lateral outflow. The lateral outflow is available to become baseflow.

Groundwater 2 storage represents the total storage in the lower groundwater layer. It may be zero if you wish to eliminate the lower

groundwater layer and pass water percolated from the upper groundwater layer directly to deep percolation.

The groundwater 2 percolation rate sets the upper bound on deep percolation out of the system. The actual percolation rate is a linear function of the current storage in the lower groundwater layer.

The groundwater 2 coefficient is used as the time lag on a linear reservoir for transforming water in storage to become lateral outflow. It is usually a larger value than the groundwater 1 coefficient. The lateral outflow is likewise available to become baseflow.

## Selecting a Transform Method

While a subbasin element conceptually represents infiltration, surface runoff, and subsurface processes interacting together, the actual surface runoff calculations are performed by a transform method contained within the subbasin. A total of eight different transform methods are provided. The choices include various unit hydrograph methods, a kinematic wave implementation, and a linear quasi-distributed method.

The transform method for a subbasin is selected on the *Component Editor* for the subbasin element. Access the *Component Editor* by clicking the subbasin element icon on the "Components" tab of the *Watershed Explorer* (Figure 121). You can also access the *Component Editor* by clicking on the element icon in the basin map, if the map is currently open. You can select a transform method from the list of seven available choices. If you choose the `None` method, the subbasin will transform all excess precipitation as runoff at the end of each time step. Use the selection list to choose the method you wish to use. Each subbasin may use a different method or several subbasins may use the same method.

When a new subbasin is created, it is automatically set to use the default transform method specified in the program settings. You may change the transform method for a subbasin at any time using the *Component Editor* for the subbasin element. Since a subbasin can only use one transform method at a time, you will be warned when changing methods that the old parameter data will be lost. You can turn off this warning in the program settings. You can change the transform method for several subbasins simultaneously. Click on the **Parameters** menu and select the **Transform ⇒ Change Method** command. The transform method you choose will be applied to the selected subbasins in the basin model, or to all subbasins if none are currently selected.

The parameters for each transform method are presented on a separate *Component Editor* from the subbasin element editor. The "Transform" editor is always shown near to the "Loss" editor. The kinematic wave method uses multiple tabs in the *Component Editor*. The information shown on the transform editor will depend on which method is currently selected.

### **Clark Unit Hydrograph Transform**

The Clark unit hydrograph is a synthetic unit hydrograph method. This means that the user is not required to develop a unit hydrograph through the analysis of past observed hydrographs. Instead, a time versus area curve (time-area curve) built into the program is used to develop the translation hydrograph resulting from a burst of precipitation. The resulting translation hydrograph is routed through a linear reservoir to account for storage attenuation effects across the subbasin. The *Component Editor* is shown in Figure 138.

Basin Name: Post Dam	
Element Name: Deer Cr	
*Time of Concentration (HR)	6.0
*Storage Coefficient (HR)	9.5
Time-Area Method:	Default

Figure 138. Clark unit hydrograph transform method editor.

The time of concentration defines the maximum travel time in the subbasin. It is used in the development of the translation hydrograph.

The storage coefficient is used in the linear reservoir that accounts for storage effects. A dimensionless ratio can be defined as the storage coefficient divided by the sum of the time of concentration and storage coefficient. Many studies have found that the dimensionless ratio is relatively constant over a region.

The default time-area curve represents the subbasin using a diamond shape. This shape has been shown to approximate the timing of surface runoff very well for typical subbasins. However, there is also an option to provide a user-specified time-area curve. The relationship must be defined as a percentage curve in the paired data manager before it can be used in the subbasin element. The independent axis of the percentage curve defines the percentage of the time of concentration, while the dependent axis of the curve defines the cumulative percentage of subbasin area contributing runoff. The curve must be monotonically increasing.



## Kinematic Wave Transform

The kinematic wave method is designed principally for representing urban areas, although it can be used for undeveloped regions as well. It is a conceptual model that includes one or two representative planes. Typically, one plane is used for pervious surfaces and one for impervious. The same meteorologic boundary conditions are applied to each plane. However, separate loss rate information is required for each plane and is entered separately as part of the loss method. A separate *Component Editor* is provided for each plane; they are displayed whenever the *Component Editor* is shown for the subbasin (Figure 139).

Basin Name: Post Dam	
Element Name: Deer Cr	
*Length (FT)	35
*Slope (FT/FT)	0.02
*Roughness:	0.45
*Area (%)	70
Routing Steps:	5

Figure 139. Plane editor for the kinematic wave transform method. The same properties are required for the second plane, if it is used.

The first parameter is the length. The typical length of the conceptual plane should be entered. For impervious areas, this should be the average flow length from the point where precipitation falls, to where the runoff first enters a collection gutter or channel. For pervious areas, this should likewise be the average flow length. When using the two planes to represent pervious and impervious areas, it is helpful to adopt a convention for which plane number (one or two) represents the pervious area.

The slope is also required for each plane that will be used. The slope should represent the average slope along the flow line from the point where precipitation falls to where the runoff first enters a gutter or channel.

Roughness is the principal difference between a plane meant to represent impervious or pervious area. Roughness coefficients for natural areas are much higher than for developed areas. However, in both cases the surface roughness coefficients are higher than typical Manning's roughness coefficients used for open channel flow.

The percentage of the subbasin area occupied by each plane must be entered. If you only want to use one plane, then enter 100 for the first plane and 0 for the second. You do not need to enter length, slope, or roughness if the area will be set to zero.

The number of routing steps is used as a hint to the program when it determines the correct distance step to use during runoff calculations. Criteria based on rate of precipitation and other factors are used to automatically determine the correct distance and time steps for solving the kinematic wave equation. The default value is five.

The outflow from each plane is scaled up to the subbasin according to the percentage of the subbasin occupied by each plane type. The resulting composite outflow is linked to a subcollector channel (Figure 140). The subcollector is intended to represent primary collection systems such as street gutters but cross section choices allow alternate representations. The outflow from the planes is applied to the subcollector as lateral inflow.

Subcollector		Loss 1	Loss 2	Channel	Collector
Subcollector		Plane 2	Plane 1	Baseflow	Options
<b>Basin Name: Post Dam</b>					
<b>Element Name: Deer Cr</b>					
*Length (FT)	320				
*Slope (FT/FT)	0.005				
*Manning's n:	0.023				
Subreaches:	5				
*Area (MI2)	0.12				
Shape:	Trapezoid				
*Bottom Width (FT)	0.5				
*Side Slope (xH:1V)	1.0				

Figure 140. Subcollector editor for the kinematic wave transform method. The same properties are required for the collector, if it is used.

The length should be the average distance from the beginning of the subcollector to where it will enter a collector. Usually this value will be measured from maps of the stormwater collection system.

The slope should be the average slope along the average flow length. This value may be estimated from maps if they provide sufficient vertical resolution. Field survey data may be necessary to actually determine elevations of the gutter or channel. If the slope varies significantly throughout the system, this may become a determining factor in how the system is broken into subcollectors, collectors, and main channel.

The Manning's  $n$  roughness coefficient should be the average value for the whole subcollector. It is important to remember that the parameter data entered for the subcollector should be typical of all similar subcollectors in the subbasin.

The number of subreaches is used as a hint to the program when it determines the correct distance step to use during routing calculations. The default value is five.

The typical area of each subcollector must be entered. This is used to determine how to apply the composite outflow from the subcollector to the collector channel. It essentially determines the number of subcollector channels in the subbasin.

Five options are provided for specifying the cross section shape: circle, deep, rectangle, trapezoid, and triangle. The circle shape cannot be used for pressure flow or pipe networks, but is suitable for representing a free water surface inside a pipe. The deep shape should only be used for flow conditions where the flow depth is approximately equal to the flow width. Depending on the shape you choose, additional information will have to be entered to describe the size of the cross section shape. This information may include a diameter (circle) bottom width (deep, rectangle, trapezoid) or side slope (trapezoid, triangle). The side slope is dimensionless and entered as the units of horizontal distance per one unit of vertical distance.

The outflow from the subcollector enters a collector as lateral inflow. The collector channel is intended to represent small ditches or open channels that are part of an engineered stormwater management system. The parameters for the collector are exactly the same as for the subcollector. Length, slope, Manning's  $n$ , and the number of subreaches all have the same definitions. The area served by a typical collector must be entered; this is used to apply lateral inflow from the collector to the main channel. Options for the cross section shape are exactly the same as for the subcollector.

Finally, the outflow from the collector enters a main channel (Figure 141). The channel is intended to represent the main stream in the subbasin. Outflow from the collector is applied to the channel as lateral inflow. Optionally, upstream inflow can be connected to the channel.

Subcollector	Plane 2	Plane 1	Baseflow	Options
Subbasin	Loss 1	Loss 2	Channel	Collector
<p><b>Basin Name: Post Dam</b></p> <p><b>Element Name: Deer Cr</b></p> <p>Route Upstream: No</p> <p>Routing Method: Kinematic Wave</p> <p>*Length (FT) 7560</p> <p>*Slope (FT/FT) 0.001</p> <p>Subreaches: 5</p> <p>Shape: Rectangle</p> <p>*Manning's n: 0.012</p> <p>*Width (FT) 5.75</p>				

Figure 141. Channel editor for the kinematic wave transform method.

Normally it is not possible to connect upstream inflow to a subbasin element. However, because of the conceptual representation of the kinematic wave method, it is possible to have an upstream inflow on the main channel. In order to connect upstream elements to the subbasin, you must select the "Route Upstream" option.

The surface runoff on the two planes is always routed using the kinematic wave method. However, you have the choice of using Muskingum-Cunge routing in the subcollector, collector, and main channel. All three channels use the same method. Select the method you wish to use.

If the route upstream option is turned on, the length should be the distance from the upstream boundary to the subbasin to the outlet. If the route upstream option is turned off, the length should be from the identifiable concentration point of the channel to the subbasin outlet. There is only one channel in each subbasin.

The slope should be the average slope for the whole channel. This value may be estimated from maps if they provide sufficient vertical resolution. Field survey data may be necessary to actually determine elevations of the channel bed for calculating the slope.

The number of subreaches is used as a hint to the program when it determines the correct distance step to use during routing calculations. The default value is five. This parameter is only entered when the kinematic wave routing method is selected.

A cross section shape must be selected. If the kinematic wave routing method is selected, the options will include circle, deep, rectangle, trapezoid, and triangle. When the Muskingum-Cunge routing method

is selected, the options will include circular, rectangle, trapezoid, triangle, and eight point. You will have to enter a Manning's n roughness value for the channel. If the eight point cross section shape is used, you will also have to enter a roughness value for the left and right overbank areas. You will have to enter other appropriate parameter data based on the cross section choice.

### **ModClark Transform**

The ModClark method is a linear, quasi-distributed transform method that is based on the Clark conceptual unit hydrograph. It fundamentally represents the subbasin as a collection of grid cells. The Clark method uses a time-area curve and the time of concentration to develop a translation hydrograph. By contrast, the ModClark method eliminates the time-area curve and instead uses a separate travel time index for each grid cell. The travel time index for each cell is scaled by the overall time of concentration. Excess precipitation falling on each grid cell is lagged by the scaled time index and then routed through a linear reservoir. The outputs from the linear reservoirs of the cells are combined to produce the final hydrograph. External utility programs are used to create the grid cell information at one of the following cell sizes: 10, 20, 50, 100, 200, 500, 1000, 2000, 5000, 10000 meters. The *Component Editor* is shown in Figure 142.

Basin Name: Post Dam	
Element Name: Deer Cr	
*Time of Concentration (HR)	12.8
*Storage Coefficient (HR)	22.5

Figure 142. ModClark transform method editor.

The time of concentration defines the maximum travel time in the subbasin. The grid cell in the subbasin with the largest travel time index will have exactly this specified time of concentration. All other grid cells will have a scaled time of concentration based on the ratio of the cell's travel time index to the maximum travel time index.

The storage coefficient is used in the linear reservoir for each grid cell. The same coefficient is used for all cells in the subbasin.

## SCS Unit Hydrograph Transform

The Soil Conservation Service (SCS) unit hydrograph method defines a curvilinear unit hydrograph by first setting the percentage of the unit runoff that occurs before the peak flow (NRCS, 2007). A triangular unit hydrograph can then be fit to the curvilinear unit hydrograph so that the total time base of the unit hydrograph can be calculated. The standard unit hydrograph is defined with 37.5% of unit runoff occurring before the peak flow. This definition corresponds to a peak rate factor of 484 which incorporates the percentage of unit runoff before the peak, calculated total time base, and unit conversions when applying the equations within the US Customary unit system. An example of the *Component Editor* is shown in Figure 143.

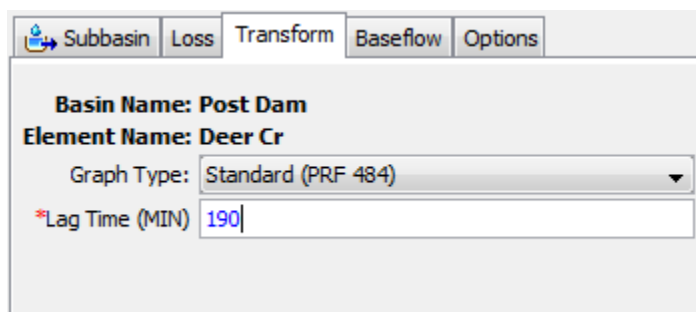

The screenshot shows a software interface with a tabbed menu at the top containing 'Subbasin', 'Loss', 'Transform', 'Baseflow', and 'Options'. The 'Transform' tab is active. Below the tabs, the following information is displayed:

- Basin Name: Post Dam
- Element Name: Deer Cr
- Graph Type: Standard (PRF 484) (dropdown menu)
- \*Lag Time (MIN): 190 (text input field)

Figure 143. SCS unit hydrograph transform method editor.

The percentage of unit runoff occurring before the peak flow is not uniform across all watersheds because it depends on flow length, ground slope, and other properties of the watershed. By changing the percentage of unit runoff before the peak, alternate unit hydrographs can be computed for watersheds with varying topography and other conditions that effect runoff. The percentage of runoff occurring before the peak is reflected in the peak rate factor (PRF). It has been found that flat watersheds typically have a lower PRF that may be as small as 100. Steeper watersheds have a larger PRF that may range up to 600. The default unit hydrograph has a PRF of 484. Unit hydrographs with specific peak rate factors are defined in the National Engineering Handbook (NRCS, 2007). A very specific case of the unit hydrograph for flat coastal watersheds is known as the Delmarva unit hydrograph (Welle, Woodward, and Moody, 1980).

The standard lag is defined as the length of time between the centroid of precipitation mass and the peak flow of the resulting hydrograph. Examination of the equations used in deriving the curvilinear unit hydrograph show that the lag time can be computed as the duration of unit precipitation divided by two, plus 60% of the time of concentration.

## Snyder Unit Hydrograph Transform

The Snyder unit hydrograph is a synthetic unit hydrograph method. The original data only supported computing the peak flow as the result of a unit of precipitation. Later, equations were developed to estimate the time base of the hydrograph and the width at 50% of the peak flow. Since it does not compute all ordinates of the hydrograph, a Clark hydrograph is created in such a way that the Snyder properties are maintained.

### Standard Method

The standard method requires the user to estimate parameters using appropriate techniques. Many approaches have been proposed for estimating the parameters, relying on different physical properties of the watershed under consideration. The approaches are typically developed by fitting the unit hydrograph parameters for a watershed with observed precipitation and discharge data. These approaches may be effective at estimating parameters in ungaged watersheds if they are similar to the watersheds used to develop the approach. The *Component Editor* is shown in Figure 144.

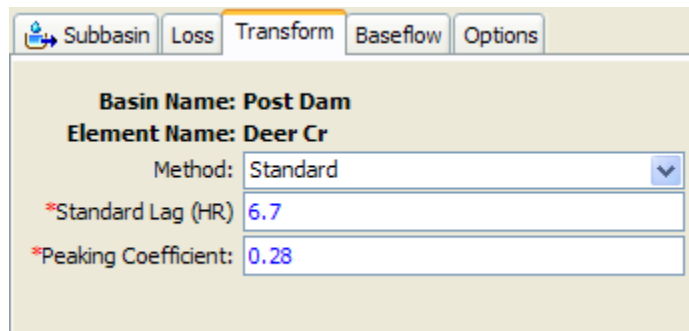

The screenshot shows a software interface for editing hydrograph parameters. At the top, there are five tabs: 'Subbasin', 'Loss', 'Transform' (which is highlighted), 'Baseflow', and 'Options'. Below the tabs, the 'Basin Name' is 'Post Dam' and the 'Element Name' is 'Deer Cr'. There are three input fields: 'Method' is a dropdown menu set to 'Standard'; '\*Standard Lag (HR)' is a text box containing '6.7'; and '\*Peaking Coefficient' is a text box containing '0.28'.

Figure 144. Snyder unit hydrograph transform method editor.

The standard lag is defined as the length of time between the centroid of precipitation mass and the peak flow of the resulting hydrograph. Many relationships for estimating lag from subbasin characteristics have been developed for different regions.

The peaking coefficient measures the steepness of the hydrograph that results from a unit of precipitation. It ranges typically from 0.4 to 0.8 with lower values associated with steep-rising hydrographs. It is estimated using the best judgement of the user, or possibly from locally-developed relationships to watershed physical features.

### Ft Worth District Method

The Ft Worth method is the result of regional urban studies conducted by the U.S. Army Corps of Engineers, Ft. Worth District in the Dallas-Ft

Worth, Austin, and San Antonio areas. The method is applicable for watersheds substantially similar to the watersheds included in the regional study. The user enters values for five physical characteristics of a subbasin. Equations from the regional study use the parameter values to calculate the Snyder standard lag. The *Component Editor* is shown in Figure 145.

The total length is measured from the outlet of the subbasin, along the main watercourse to the most hydraulically remote point on the subbasin boundary.

The centroid length is measured from the outlet of the subbasin, along the main watercourse, to a point opposite the subbasin centroid.

The weighted slope is the slope of the main watercourse between points located at 10 percent and 85 percent of the length of the main watercourse, measured from the subbasin outlet.

Basin Name: Post Dam	
Element Name: Deer Cr	
Method:	Ft Worth District
*Length (MI)	5.4
*Centroid Length (MI)	3.9
*Weighted Slope (FT/MI)	6.25
*Urbanization (%)	18
*Sand (%)	40
*Peaking Coefficient:	0.34

Figure 145. Snyder unit hydrograph transform method editor showing Ft Worth District parameter estimation.

Urbanization percentage is estimated as the percentage of the subbasin where the drainage system has been improved to more efficiently carry runoff to the outlet. Such improvements may include street gutters, straightened channels, concrete lined channels, or other efficiencies. This parameter provides a way to account for the effects of urbanization on the hydrologic response of the subbasin.

The sand percentage accounts for the effect of infiltration and surface runoff properties on hydrograph generation. Zero percent indicates essentially all-clay soils with characteristically low infiltration rates. Conversely, 100 percent indicates essentially all-sandy soils with characteristically high infiltration rates.



The Fort Worth method does not include estimation of the peaking coefficient. This parameter must be estimated by another method and entered directly.

### ***Tulsa District Method***

The Tulsa method is the result of regional urban studies conducted by the U.S. Army Corps of Engineers, Tulsa District using watersheds across Oklahoma. The method is applicable for watersheds substantially similar to the watersheds included in the regional study. The user enters values for four physical characteristics of a subbasin. The values are used with equations developed in the regional study for estimating the standard lag and peaking coefficient. The *Component Editor* is shown in Figure 146.

The screenshot shows a software interface with a tabbed menu at the top containing 'Subbasin', 'Loss', 'Transform', 'Baseflow', and 'Options'. The 'Transform' tab is active. Below the tabs, the following information is displayed:

- Basin Name: Post Dam
- Element Name: Deer Cr
- Method: Tulsa District (selected in a dropdown menu)
- \*Length (MI): 4.8
- \*Centroid Length (MI): 3.1
- \*Weighted Slope (FT/MI): 5.75
- \*Channelization (%): 30

Figure 146. Snyder unit hydrograph transform method editor showing Tulsa District parameter estimation.

The total length is measured from the outlet of the subbasin, along the main watercourse to the most hydraulically remote point on the subbasin boundary.

The centroid length is measured from the outlet of the subbasin, along the main watercourse, to a point opposite the subbasin centroid.

The weighted slope is the slope of the main watercourse between points located at 10 percent and 85 percent of the length of the main watercourse, measured from the subbasin outlet.

Channelization percentage is estimated as the percentage of the subbasin where the drainage system has been improved to more efficiently carry runoff to the outlet. Such improvements may include street gutters, straightened channels, concrete lined channels, or other efficiencies. This parameter provides a way to account for the effects of urbanization on the hydrologic response of the subbasin.

## User-Specified S-Graph Transform

The user-specified s-graph method is not synthetic. It uses a special summation unit hydrograph (abbreviated as s-graph) to represent the response of a subbasin to a unit of precipitation. The s-graph is defined with percentage of the time lag as the independent variable (x axis), and percentage of the cumulative runoff volume as the dependent variable (y axis). Computationally, the s-graph is scaled by a specified time lag and then successive differences are taken along the curve to compute a unit hydrograph directly from the scaled s-graph. A given s-graph is generally only applicable in a particular region with subbasins that share certain characteristics.

The s-graph must be chosen from a selection list of percentage curves defined previously in the paired data manager. While percentage curves are used for other applications in the program, in this case they represent percentage of unit discharge versus percentage of time lag. You will not be able to use the selection list until you create at least one s-graph. If you wish, you can use the paired data button next to the selection list to open a chooser that will assist in selecting the correct s-graph. Click on a percentage curve to view its description. Descriptions are particularly important for percentage curves because of the different applications in the program.

There are two different methods for specifying the lag time to be applied to the s-graph. The `Standard` method allows the simple specification of the lag time in hours. The lag time is defined as the length of time between the centroid of precipitation mass and the peak flow of the resulting hydrograph. An example of this method is shown in Figure 147.

The screenshot shows a software interface for configuring a subbasin element. At the top, there are five tabs: 'Subbasin', 'Loss', 'Transform', 'Baseflow', and 'Options'. The 'Transform' tab is selected. Below the tabs, the following information is displayed:

- Basin Name:** Post Dam
- Element Name:** Deer Cr
- \*S-Graph:** Mountain Valleys (with a small graph icon to the right)
- Method:** Standard
- \*Lag Time (HR):** 6.5

Figure 147. User-specified s-graph transform method editor with a specified time lag in hours.

The `Regression` method provides for the automatic calculation of the lag time using an equation commonly applied in regional regression studies. The equation is applied to the parameters within the context of the U.S. Customary unit system. If parameters are entered in

System International units, then the equation is evaluated after converting the parameters to U.S. Customary equivalents. The equation takes the following form for computing the lag time in hours:

$$lag = C \left( \frac{L L_{ca}}{s^p} \right)^m$$

The length of the longest flowpath in the subbasin is specified using the  $L$  parameter. The length along the stream from the outlet to a point opposite the centroid is specified by the  $L_{ca}$  parameter. A typical stream slope must be specified as the  $s$  parameter. The  $C$  coefficient describes hydraulic efficiency of the stream channel. The  $m$  and  $p$  parameters should be found through a regional regression study of watershed properties and observed lag time. An example of this method is shown in Figure 148.

Parameter	Value
*S-Graph	Mountain Valleys
Method	Regression
*Length (MI)	2.3
*Centroid Length (MI)	0.9
*Slope (FT/MI)	4.2
*Coefficient	0.79
*M Exponent	0.38
*P Exponent	0.5

Figure 148. User-specified  $s$ -graph transform method editor with a site-specific example of regression parameter values.

### User-Specified Unit Hydrograph Transform

The user-specified unit hydrograph method is not a synthetic technique. Consequently, a separate unit hydrograph must be developed for each subbasin. Ideally these unit hydrographs are developed from multiple storm observations when precipitation and flow have been measured at similar time intervals. The unit hydrograph developed in this manner has a so-called duration that is equal to the duration of excess precipitation. For example, a 3-hour duration unit hydrograph is generated by a precipitation event with 3 hours of excess precipitation.

A unit hydrograph must be defined in the paired data manager before it can be used for a subbasin. An example of a unit hydrograph in the

paired data manager is shown in Figure 149. Notice the duration selection for the unit hydrograph. The duration must be set equal to the excess precipitation duration used to develop the unit hydrograph. The duration is also used as the time interval for the ordinates defining the unit hydrograph. For example, a unit hydrograph developed from excess precipitation with duration of 3 hours must define the resulting unit hydrograph with ordinates at a 3-hour interval. It is currently not possible to enter ordinates at a different time interval than the unit hydrograph duration. If more ordinates are needed to adequately define the shape of the unit hydrograph, then the user should transform the unit hydrograph original duration to a shorter duration before entering ordinates in the paired data manager.

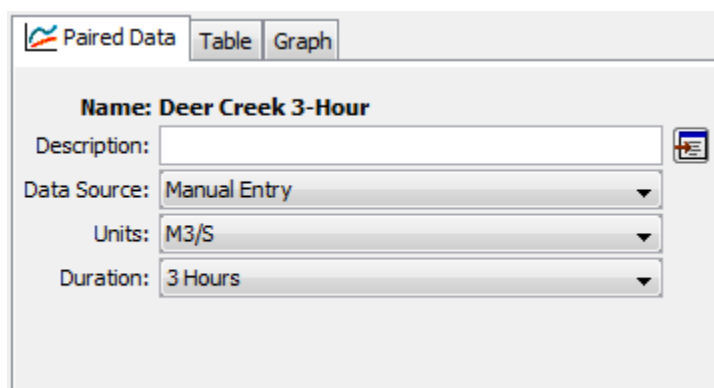

The screenshot shows a software window titled "Paired Data" with two tabs: "Table" and "Graph". The "Table" tab is active. The window contains the following fields:

- Name:** Deer Creek 3-Hour
- Description:** [Empty text box]
- Data Source:** Manual Entry (dropdown menu)
- Units:** M3/S (dropdown menu)
- Duration:** 3 Hours (dropdown menu)

Figure 149. Entering a unit hydrograph in the paired data manager.

The only parameter for the user-specified unit hydrograph method is the selection of a unit hydrograph from the paired data manager, as shown in Figure 150. The unit hydrograph must be entered in the paired data manager before it can be selected in the *Component Editor*. If you wish, you can use the paired data button next to the selection list to open a chooser to assist in selecting the correct unit hydrograph.

The unit hydrograph is defined for the duration specified in the paired data manager, and has ordinates defined at the same time interval as the duration. In simulations where the duration of the unit hydrograph is not equal to the simulation time interval, the program will automatically use the s-graph technique to match the unit hydrograph to the simulation time interval.

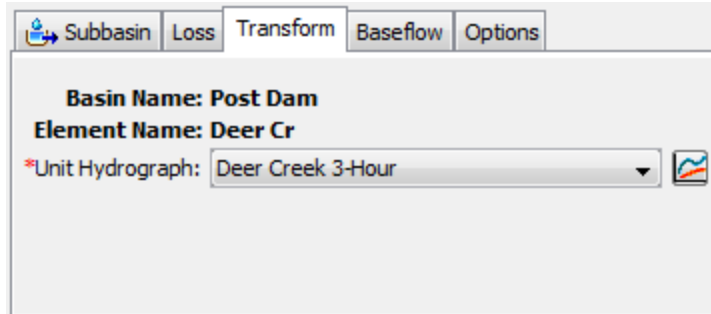

Figure 150. User-specified unit hydrograph transform method editor.

## Selecting a Baseflow Method

While a subbasin element conceptually represents infiltration, surface runoff, and subsurface processes interacting together, the actual subsurface calculations are performed by a baseflow method contained within the subbasin. A total of six different baseflow methods are provided. Some of the methods are designed primarily for simulating events while others are intended for continuous simulation.

The baseflow method for a subbasin is selected on the *Component Editor* for the subbasin element. Access the *Component Editor* by clicking the subbasin element icon on the "Components" tab of the *Watershed Explorer* (Figure 121). You can also access the *Component Editor* by clicking on the element icon in the basin map, if the map is currently open. You can select a baseflow method from the list of six available choices. If you choose the `None` method, the subbasin will not compute baseflow and the outflow will only include direct runoff from the transform method. Use the selection list to choose the method you wish to use. Each subbasin may use a different method or several subbasins may use the same method.

When a new subbasin is created, it is automatically set to use the default baseflow method specified in the program settings. You may change the baseflow method for a subbasin at any time using the *Component Editor* for the subbasin element. Since a subbasin can only use one baseflow method at a time, you will be warned when changing methods that the old parameter data will be lost. You can turn off this warning in the program settings. You can change the baseflow method for several subbasins simultaneously. Click on the **Parameters** menu and select the **Baseflow ⇒ Change Method** command. The baseflow method you choose will be applied to the selected subbasins in the basin model, or to all subbasins if none are currently selected.

The parameters for each baseflow method are presented on a separate *Component Editor* from the subbasin element editor. The "Baseflow" editor is always shown near the "Transform" editor. The information shown on the baseflow editor will depend on which method is currently selected.

### ***Bounded Recession Baseflow***

The bounded recession baseflow method is intended primarily for real-time forecasting operations. The method is very similar to the recession method, and like it, does not conserve mass in the subbasin. The principal difference is that monthly baseflow limits can be specified. The baseflow is computed according to the recession methodology and then the monthly limits are imposed. Though there are many similarities with the recession method, one important difference is that this method does not reset the baseflow after a storm event. The *Component Editor* is shown in Figure 151.

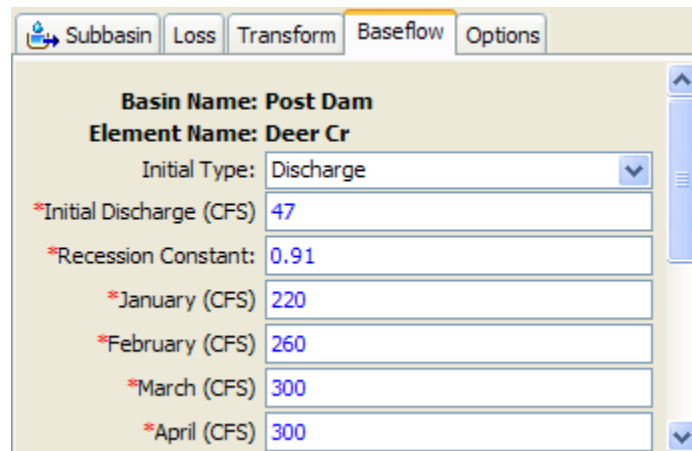

Parameter	Value
Basin Name	Post Dam
Element Name	Deer Cr
Initial Type	Discharge
*Initial Discharge (CFS)	47
*Recession Constant	0.91
*January (CFS)	220
*February (CFS)	260
*March (CFS)	300
*April (CFS)	300

Figure 151. Bounded recession baseflow method editor.

The initial baseflow at the beginning of a simulation must be specified. Two methods are available for specifying the initial condition: initial discharge and initial discharge per area. Using the first method, you must specify the initial baseflow as a discharge with units of volume per time. This method is particularly good when there is observed streamflow data at the outlet of the subbasin for determining the initial flow in the channel. In the second method you specify the initial baseflow as a volume per area per time. This method is better suited when general guidelines for watershed yield must be used to estimate the initial flow.

The recession constant describes the rate at which baseflow recedes between storm events. It is defined as the ratio of baseflow at the current time, to the baseflow one day earlier.

A baseflow value must be entered for the month of January. Likewise, a value must also be entered for each of the remaining months from February to December. This value is used to limit the computed baseflow.

### **Constant Monthly Baseflow**

The constant monthly baseflow method allows the specification of a constant baseflow for each month of the year. It does not conserve mass within the subbasin. It is intended primarily for continuous simulation in subbasins where the baseflow is nicely approximated by a constant flow for each month. The *Component Editor* is shown in Figure 152.

A baseflow value must be entered for the month of January. Likewise, a value must also be entered for each of the remaining months from February to December.

Month	Baseflow (CFS)
*January (CFS)	100
*February (CFS)	110
*March (CFS)	130
*April (CFS)	180
*May (CFS)	260
*June (CFS)	270
*July (CFS)	250

Figure 152. Constant monthly baseflow method editor.

### **Linear Reservoir Baseflow**

The linear reservoir baseflow method, as its name implies, uses a linear reservoir to model the recession of baseflow after a storm event. It conserves mass within the subbasin. Infiltration computed by the loss method is connected as the inflow to the linear reservoir. It can be used with one or two layers. When it is used with the soil moisture accounting or gridded soil moisture accounting methods, the infiltration is connected to the lateral outflow of the groundwater layers. For all other loss methods, the computed infiltration is separated equally between the two layers defined in the baseflow method. The *Component Editor* is shown in Figure 153.

The screenshot shows a software dialog box titled "Linear reservoir baseflow method editor". At the top, there are five tabs: "Subbasin", "Loss", "Transform", "Baseflow" (which is highlighted), and "Options". Below the tabs, the dialog contains the following fields and values:

- Basin Name:** Post Dam
- Element Name:** Deer Cr
- Initial Type:** Discharge (selected from a dropdown menu)
- \*GW 1 Initial (CFS):** 210
- \*GW 1 Coefficient:** 12
- GW 1 Reservoirs:** 2 (indicated by a spinner control)
- GW 2 Initial (CFS):** (empty field)
- GW 2 Coefficient:** (empty field)
- GW 2 Reservoirs:** 1 (indicated by a spinner control)

Figure 153. Linear reservoir baseflow method editor.

The initial baseflow at the beginning of a simulation must be specified. Two methods are available for specifying the initial condition: initial discharge and initial discharge per area. Using the first method, you must specify the initial baseflow as a discharge with units of volume per time. This method is particularly good when there is observed streamflow data at the outlet of the subbasin for determining the initial flow in the channel. In the second method you specify the initial baseflow as a volume per area per time. This method is better suited when general guidelines for watershed yield must be used to estimate the initial flow. The same method must be used for specifying the initial condition for both layers.

The groundwater storage coefficient is the time constant for the linear reservoir in each layer. Since it is measured in hours, it gives a sense of the response time of the subbasin.

The number of groundwater reservoirs can be used so that baseflow is routing through several sequential reservoirs. Minimum attenuation is achieved when only one routing step is selected. Attenuation of the baseflow increases as the number of steps increases.

### ***Nonlinear Boussinesq Baseflow***

The nonlinear Boussinesq baseflow method is designed to approximate the typical behavior observed in watersheds when channel flow recedes after an event. It is similar to the recession baseflow method, but by assuming an unconfined groundwater layer and invoking the Boussinesq assumptions, it is possible to parameterize the method using measurable field data. This method is intended primarily for event simulation. However, it does have the ability to automatically reset after each storm event and consequently may be used for continuous simulation. It does not conserve mass within the subbasin. The *Component Editor* is shown in Figure 154.



Basin Name: Post Dam	
Element Name: Deer Cr	
Initial Type:	Discharge
*Initial Discharge (CFS)	210
Threshold Type:	Ratio To Peak
*Ratio:	0.2
*Length: (FT)	4800
*Conductivity: (IN/HR)	0.47
*Porosity:	0.42

Figure 154. Nonlinear Boussinesq baseflow method editor.

The initial baseflow at the beginning of a simulation must be specified. Two methods are available for specifying the initial condition: initial discharge and initial discharge per area. Using the first method, you must specify the initial baseflow as a discharge with units of volume per time. This method is particularly good when there is observed streamflow data at the outlet of the subbasin for determining the initial flow in the channel. In the second method you specify the initial baseflow as a volume per area per time. This method is better suited when general guidelines for watershed yield must be used to estimate the initial flow.

There are two different methods for determining how to reset the baseflow during a storm event: ratio to peak and threshold flow. When using the ratio to peak method, you must specify the flow ratio to the peak. The baseflow is reset when the current flow divided by the peak flow is falls to the specified value. For example, if a ratio of 0.2 is selected, the baseflow will be reset on the receding limb of an event hydrograph when the flow has decreased to 20% of the event peak flow. With the threshold flow method, the baseflow is always reset when the receding limb of the hydrograph falls to a specified flow value, regardless of the peak flow during the previous storm event.

The characteristic subsurface flow length must be specified. This could be estimated as the mean distance from the subbasin boundary to the stream.

The conductivity of the soil must be specified. This could be estimated from field tests or from the soil texture.

The drainable porosity must be specified in terms of volume ratio. The upper limit would be the total porosity minus the residual porosity. The actual drainable porosity depends on local conditions.

## Recession Baseflow

The recession baseflow method is designed to approximate the typical behavior observed in watersheds when channel flow recedes exponentially after an event. This method is intended primarily for event simulation. However, it does have the ability to automatically reset after each storm event and consequently may be used for continuous simulation. It does not conserve mass within the subbasin. The *Component Editor* is shown in Figure 155.

The initial baseflow at the beginning of a simulation must be specified. Two methods are available for specifying the initial condition: initial discharge and initial discharge per area. Using the first method, you must specify the initial baseflow as a discharge with units of volume per time. This method is particularly good when there is observed streamflow data at the outlet of the subbasin for determining the initial flow in the channel. In the second method you specify the initial baseflow as a volume per area per time. This method is better suited when general guidelines for watershed yield must be used to estimate the initial flow.

Basin Name: Post Dam	
Element Name: Deer Cr	
Initial Type:	Discharge Per Area
*Initial Discharge (CFS/MI2)	0.9
*Recession Constant:	0.91
Threshold Type:	Ratio To Peak
*Ratio:	0.25

Figure 155. Recession baseflow method editor.

The recession constant describes the rate at which baseflow recedes between storm events. It is defined as the ratio of baseflow at the current time, to the baseflow one day earlier.

There are two different methods for determining how to reset the baseflow during a storm event: ratio to peak and threshold flow. When using the ratio to peak method, you must specify the flow ratio to the peak. The baseflow is reset when the current flow divided by the peak flow is falls to the specified value. For example, if a ratio of 0.2 is selected, the baseflow will be reset on the receding limb of an event hydrograph when the flow has decreased to 20% of the event peak flow. With the threshold flow method, the baseflow is always reset

when the receding limb of the hydrograph falls to a specified flow value, regardless of the peak flow during the previous storm event.

## **References**

Natural Resources Conservation Service (NRCS). 2007. *National Engineering Handbook: Chapter 16 Hydrographs*. Washington, DC.

Welle, P., D. Woodward, and H. Moody. 1980. "A Dimensionless Unit Hydrograph for the Delmarva Peninsula." American Society of Agricultural Engineers Paper 80-2013, St. Joseph, Michigan.

This Page Left Blank

## CHAPTER 8

# *Reach Elements*

A reach is an element with one or more inflow and only one outflow. Inflow comes from other elements in the basin model. If there is more than one inflow, all inflow is added together before computing the outflow. Outflow is computed using one of the several available methods for simulating open channel flow. Optionally it may include a method for representing interactions with the subsurface. The reach element can be used to model rivers and streams.

### *Selecting a Routing Method*

While a reach element conceptually represents a segment of stream or river, the actual calculations are performed by a routing method contained within the reach. A total of seven different routing methods are provided. Each of the methods implements a hydrologic routing methodology as compared to a hydraulic approach that implements the full unsteady flow equations. Each method included in the program provides a different level of detail and not all methods are equally adept at representing a particular stream.

The routing method for a reach is selected on the *Component Editor* for the reach element. Access the *Component Editor* by clicking the reach element icon on the "Components" tab of the *Watershed Explorer* (Figure 156). You can also access the *Component Editor* by clicking on the element icon in the basin map, if the map is currently open. You can select a routing method from the list of seven available choices. If you choose the `NONE` method, the reach will translate flow instantaneously and without attenuation. Use the selection list to choose the method you wish to use. Each reach may use a different method or several reaches may use the same method.

When a new reach is created, it is automatically set to use the default routing method specified in the program settings. You may change the routing method for a reach at any time using the *Component Editor* for the reach element. Since a reach can only use one routing method at a time, you will be warned when changing methods that the old parameter data will be lost. You can turn off this warning in the program settings. You can change the routing method for several reaches simultaneously. Click on the **Parameters** menu and select the **Routing** ⇒ **Change Method** command. The routing method you

choose will be applied to the selected reaches in the basin model, or to all reaches if none are currently selected.

The parameters for each routing method are presented on a separate *Component Editor* from the reach element editor. The "Routing" editor is always shown next to the "Reach" editor. The information shown on the routing editor will depend on which method is currently selected.

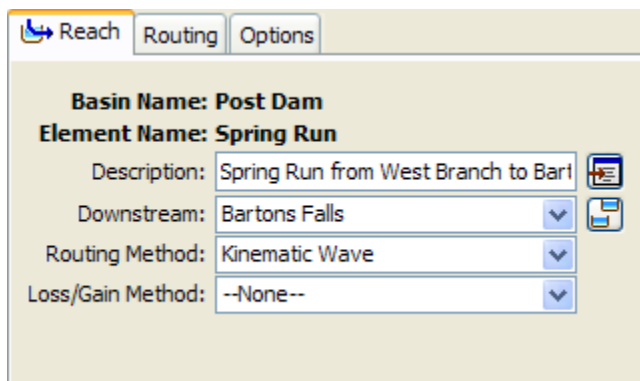

Figure 156. Reach component editor. All element editors include the basin model and element name, description, and downstream connection. The reach editor also has the routing and loss/gain method selections.

### **Kinematic Wave Routing**

The kinematic wave routing method approximates the full unsteady flow equations by ignoring inertial and pressure forces. It also is assumed that the energy slope is equal to the bed slope. Consequently, this method is best suited to fairly steep streams. It is often used in urban areas where natural channels have been modified to have regular shapes and slopes. The *Component Editor* is shown in Figure 157.

The length should be the total length of the reach element. Usually this value will be measured from maps of the watershed.

Figure 157. Kinematic wave routing method editor.

The slope should be the average slope for the whole reach. This value may be estimated from maps if they provide sufficient vertical resolution. Field survey data may be necessary to actually determine elevations of the channel bed for calculating the slope. If the slope varies significantly throughout the stream represented by the reach, it may be necessary to use multiple reaches with different slopes.

The Manning's n roughness coefficient should be the average value for the whole reach. This value can be estimated from pictures of streams with known roughness coefficient (Barnes, 1967) or by calibration.

The number of subreaches is used as a hint to the program when it determines the correct distance step to use during routing calculations. Criteria based on steepness of the inflow hydrograph and other factors are used to automatically determine the correct distance and time steps for solving the kinematic wave equation. The default value is 2 but may be optionally increased.

Five options are provided for specifying the cross section shape: circle, deep, rectangle, trapezoid, and triangle. The circle shape cannot be used for pressure flow or pipe networks, but is suitable for representing a free water surface inside a pipe. The deep shape should only be used for flow conditions where the flow depth is approximately equal to the flow width. Depending on the shape you choose, additional information will have to be entered to describe the size of the cross section shape. This information may include a diameter (circle) bottom width (deep, rectangle, trapezoid) or side slope (trapezoid, triangle). The side slope is dimensionless and entered as the units of horizontal distance per one unit of vertical distance.

## Lag Routing

The lag routing method only represents the translation of flood waves. It does not include any representation of attenuation or diffusion processes. Consequently, it is best suited to short stream segments with a predictable travel time that doesn't vary with flow depth. The *Component Editor* is shown in Figure 158.

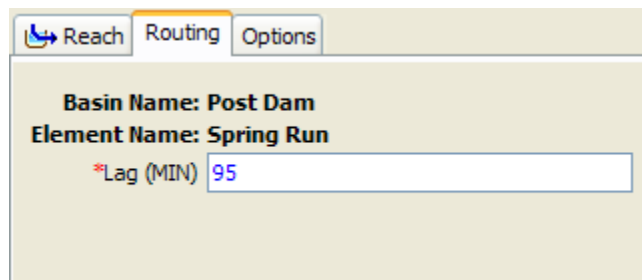

Figure 158. Lag routing method editor.

The only parameter is the lag time in minutes. Inflow to the reach is delayed in time by an amount equal to the specified lag, and then becomes outflow.

## Modified Puls Routing

The modified Puls routing method is also known as storage routing or level pool routing. It uses conservation of mass and a relationship between storage and discharge to route flow through the stream reach. Attenuation is achieved through the storage and delayed release of water in the reach instead of through a rigorous conservation of momentum approach. It can be useful for representing backwater due to flow constrictions in a channel so long as the backwater effects are fully contained within the reach. The *Component Editor* is shown in Figure 159.

A storage-discharge function defines the amount of outflow for a specific amount of storage in the reach. Storage is the independent variable and the values entered must cover the entire range of storages that may be encountered during a simulation. Usually the first storage will be zero and the maximum storage should be slightly more than the volume in the stream reach when it is at maximum flow. Generally the outflow values corresponding to each storage value are computed with the assistance of a hydraulic model that computes water surface profiles. The function must be monotonically increasing. The storage-discharge function must be defined in the paired data manager before it can be used in the reach element.



Figure 159. Modified Puls routing method editor. The optional elevation-discharge function is disabled because no curves are currently available for selection. The invert can be entered after a curve is selected.

The number of subreaches must be entered. It affects attenuation where one subreach gives the maximum attenuation and increasing the number of subreaches approaches zero attenuation. This parameter is necessary because the travel time through a subreach should be approximately equal to the simulation time step. A good estimate is to divide the actual reach length by the product of the wave celerity and the simulation time step. It can also be a calibration parameter in some cases.

There are two options for initial condition: specified discharge, and inflow equals outflow. If you use the first option, you will also have to enter a discharge value. The initial storage in the reach will be calculated from the specified discharge and the storage-discharge function. If you use the second option, it will be assumed that the initial outflow is the same as the initial inflow to the reach from upstream elements. This is essentially the same as assuming a steady-state initial condition. The initial storage will be computed from the first inflow to the reach and storage-discharge function.

Optionally an elevation-discharge function can be selected. If used, it should represent the depth of water for any given outflow from the reach. The function must be monotonically increasing. The elevation-discharge function must be defined in the paired data manager before it can be used in the reach element.

If the optional elevation-discharge function is selected, then an invert elevation should also be specified. The flow depth is added to the invert elevation to compute the stage.

## Muskingum Routing

The Muskingum routing method uses a simple conservation of mass approach to route flow through the stream reach. However, it does not assume that the water surface is level. By assuming a linear, but non-level, water surface it is possible to account for increased storage during the rising side of a flood wave and decreased storage during the falling side. By adding a travel time for the reach and a weighting between the influence of inflow and outflow, it is possible to approximate attenuation. The *Component Editor* is shown in Figure 160.

Figure 160. Muskingum routing method editor.

The Muskingum K is essentially the travel time through the reach. It can be estimated from knowledge of the cross section properties and flow properties. It may be a calibration parameter in some cases.

The Muskingum X is the weighting between inflow and outflow influence; it ranges from 0.0 up to 0.5. In practical application, a value of 0.0 results in maximum attenuation and 0.5 results in no attenuation. Most stream reaches require an intermediate value found through calibration.

The number of subreaches must be entered. It affects attenuation where one subreach gives more attenuation and increasing the number of subreaches decreases the attenuation. A good approximation is to divide the reach length by the product of the wave celerity and the simulation time step.

## Muskingum-Cunge Routing

The Muskingum-Cunge routing method is based on the combination of the conservation of mass and the diffusion representation of the conservation of momentum. It is sometimes referred to as a variable coefficient method because the routing parameters are recalculated every time step based on channel properties and the flow depth. It represents attenuation of flood waves and can be used in reaches with a small slope. The *Component Editor* is shown in Figure 161.

Figure 161. Muskingum-Cunge routing method editor with optional invert elevation left unspecified.

The time interval selection provides two options. The program can automatically select a fixed time interval that maintains numeric stability during the most steeply rising hydrograph. Alternately, the program can automatically vary the time interval to take as long a time interval as possible while also maintaining numeric stability.

The length should be the total length of the reach element. Usually this value will be measured from maps of the watershed.

The slope should be the average slope for the whole reach. This value may be estimated from maps if they provide sufficient vertical resolution or by field surveying. If the slope varies significantly throughout the stream represented by the reach, it may be necessary to use multiple reaches with different slopes.

The Manning's  $n$  roughness coefficient should be the average value for the whole reach. This value can be estimated from pictures of streams with known roughness coefficient (Barnes, 1967) or by calibration.

Optionally, an invert elevation may be specified. When used, the flow depth computed during the routing is added to the invert elevation to compute the stage.

Five options are provided for specifying the cross section shape: circle, eight point, rectangle, trapezoid, and triangle. The circle shape cannot be used for pressure flow or pipe networks, but is suitable for representing a free water surface inside a pipe. Depending on the shape you choose, additional information will have to be entered to describe the size of the cross section shape. This information may include a diameter (circle) bottom width (rectangle, trapezoid) or side

slope (trapezoid, triangle). The side slope is dimensionless and entered as the units of horizontal distance per one unit of vertical distance. The eight point shape requires a cross section simplified with only eight station-elevation values. The cross section is usually configured to represent the main channel plus left and right overbank areas. A separate Manning's n value is entered for each overbank. The cross section should extend from the channel invert up to the maximum water surface elevation that will be encountered during a simulation. The cross section must be created in the Paired Data Manager before it can be used in the reach.

### **Straddle Stagger Routing**

The straddle stagger method uses empirical representations of translation and attenuation processes to route water through a reach. Inflow is delayed a specified amount of time. The delayed flows are averaged over a specified amount of time to produce the final outflow. The *Component Editor* is shown in Figure 162.

The lag parameter specifies travel time through the reach. Inflow to the reach is delayed in time by an amount equal to the specified lag.

The duration parameter specifies the amount of spreading in a flood peak as it travels through the reach. The delayed inflows are averaged over this specified time duration. The duration parameter loses physical meaning when it is greater than twice the lag time.

Figure 162. Straddle stagger routing method editor.

### **Selecting a Loss/Gain Method**

While a reach element conceptually represents a segment of stream or river, optional modeling of interactions with the subsurface is performed by a loss/gain method contained within the reach. A loss/gain method represents losses from the channel, additions to the channel from groundwater, or bi-directional water movements depending on the specific implementation of a method. A total of three different gain/loss methods are provided. Each method included in the

program provides a different level of detail and not all methods are equally adept at representing a particular stream. Further, because of differing data requirements, some loss/gain methods are only compatible with certain routing methods.

The loss/gain method for a reach is selected on the *Component Editor* for the reach element. Access the *Component Editor* by clicking the reach element icon on the "Components" tab of the *Watershed Explorer* (Figure 156). You can also access the *Component Editor* by clicking on the element icon in the basin map, if the map is currently open. You can select a loss/gain method from the list of three available choices. If you choose the `None` method, the reach will perform routing calculations without including any losses or gains to the channel. Use the selection list to choose the method you wish to use. Each reach may use a different method or several reaches may use the same method.

When a new reach is created, it is automatically set to use the default loss/gain method specified in the program settings. You may change the loss/gain method for a reach at any time using the *Component Editor* for the reach element. Since a reach can only use one loss/gain method at a time, you will be warned when changing methods that the old parameter data will be lost. You can turn off this warning in the program settings. You can change the loss/gain method for several reaches simultaneously. Click on the **Parameters** menu and select the **Loss/Gain ⇒ Change Method** command. The loss/gain method you choose will be applied to the selected reaches in the basin model, or to all reaches if none are currently selected.

The parameters for each loss/gain method are presented on a separate *Component Editor* from the reach element editor. The "Loss/Gain" editor is always shown next to the "Routing" editor. The information shown on the loss/gain editor will depend on which method is currently selected.

### ***Constant Loss/Gain***

The constant loss/gain method uses an empirical relationship to calculate channel loss using a fixed flow rate reduction and a ratio of the flow. It does not include any capability to representing gaining streams. A fixed flow rate is subtracted from the routed flow and then the remainder is multiplied by a ratio. The reduced flow becomes the outflow for the reach. This method is compatible with all routing methods. The *Component Editor* is shown in Figure 163.

The flow rate parameter specifies the amount of flow to be subtracted from the inflow. It may be zero or greater than zero; if the specified value is zero then no flow rate reduction will occur. If the specified

value is greater than the inflow for a time step, then no outflow will result for that interval.

The fraction is used to reduce the inflow in linear proportion to the flow rate. After the constant value is subtracted from the routed inflow, the remainder is multiplied by the value one minus the fraction. The fraction must be between zero and one.

Figure 163. Constant loss/gain method editor.

### Percolation Loss/Gain

The percolation method uses a constant infiltration rate in combination with the inundated area in the reach to compute channel loss. It does not include any capability to representing gaining streams. This method is only compatible with the modified Puls and Muskingum-Cunge routing methods. When used with the modified Puls method, the optional elevation-discharge function and invert elevation must be specified in the routing parameters. The inundated area is calculated differently depending on the routing method. In combination with the modified Puls method, the current storage and outflow are combined with the elevation-discharge curve to compute inundated area. With the Muskingum-Cunge method, the wetted perimeter is multiplied by the reach length to compute area. The *Component Editor* is shown in Figure 164.

The rate parameter specifies percolation in terms of a flow rate per area. The inundated area is multiplied by the rate to determine the channel loss for each time interval.



The screenshot shows a software interface with four tabs: Reach, Routing, Loss/Gain, and Options. The 'Loss/Gain' tab is selected. Below the tabs, the text reads: 'Basin Name: Post Dam' and 'Element Name: Spring Run'. A text input field labeled '\*Rate (CFS/ACRE)' contains the value '0.0014'.

Figure 164. Percolation loss/gain method editor.

This Page Left Blank



## CHAPTER 9

# Reservoir Elements

A reservoir is an element with one or more inflow and one computed outflow. Inflow comes from other elements in the basin model. If there is more than one inflow, all inflow is added together before computing the outflow. It is assumed that the water surface in the reservoir pool is level. Several methods are available for defining the storage properties of the reservoir. The element can be used to model reservoirs, lakes, and ponds. Access the *Component Editor* by clicking the reservoir element icon on the "Components" tab of the *Watershed Explorer* (Figure 165).

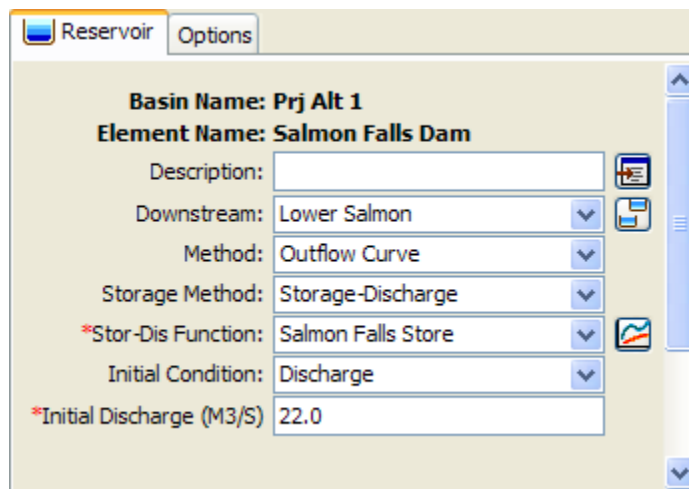

Figure 165. Reservoir component editor using the outflow curve routing method with a storage-discharge function.

## Selecting a Routing Method

While a reservoir element conceptually represents a natural lake or a lake behind a dam, the actual storage simulation calculations are performed by a routing method contained within the reservoir. Four different routing methods are available. One is designed to simply represent the reservoir with a known storage-outflow relationship. The second method uses a specified release and computes the storage that would result. The final method is designed to represent individual components of the outlet works. There is also a choice for the `None` routing method. This option assumes no storage in the reservoir and all inflow is passed as outflow for each time interval of the simulation.

The routing method for a reservoir is selected on the *Component Editor* for the reservoir element. Access the *Component Editor* by clicking the reservoir element icon on the "Components" tab of the *Watershed Explorer*. You can also access the *Component Editor* by clicking on the element icon in the basin map, if the map is currently open. You can select a routing method from the list of four available choices (Figure 165). Use the selection list to choose the method you wish to use.

The parameters for each routing method are presented below the method selection list. The exact parameter data displayed in the *Component Editor* depends on which method is selected. Some parameters are common to more than one routing method. However, all possible required and optional data for each routing method is described in the following sections.

## **Outflow Curve Routing**

This routing method represents the reservoir or lake with a user-provided relationship between storage and discharge. The water surface in the reservoir is assumed to be level. The relationship between discharge and storage must be unique, which does not permit looped rating curves. Further, the relationship must be monotonically increasing with storage. The user must develop the storage relationship external to the program by considering all the possible outlets for water from the reservoir and combining them in a single storage relationship. The simulation is accomplished with the modified Puls algorithm using one routing step.

### **Storage Method**

There are three different options for specifying the storage relationship. The first option is the *Storage-Discharge* choice. The user must select a storage-discharge curve from the available curves in the Paired Data Manager. The second option is the *Elevation-Storage-Discharge* choice. The user must select both a storage-discharge curve and elevation-storage curve from the Paired Data Manager. The final option is the *Elevation-Area-Discharge* choice. In this case the user must select both an elevation-area curve and an elevation-discharge curve from the Paired Data Manager. With this choice, the program automatically transforms the elevation-area curve into an elevation-storage curve using the conic formula. Regardless of which option is selected, the routing is always performed using only the storage-discharge curve. After the routing is complete using the storage-discharge curve, the program will compute the elevation and surface area for each time step, depending on the selected storage method.

Interpolation is used when the `Elevation-Storage-Discharge` or `Elevation-Area-Discharge` storage methods are used. This means that it is not necessary for the storage-discharge and elevation-storage curves used in the `Elevation-Storage-Discharge` method to contain matching independent variables. The two curves do not need to have the same storage values in each curve, or even have the same number of rows. At compute time, the two curves selected by the user are combined into a single routing table with three rows: elevation, storage, and discharge. The table is initially configured using the curve selected by the user as the `Primary` curve. The remaining column is interpolated from the curve *not selected* as the primary curve. Finally the storage routing is completed from the combined table using the storage and outflow columns, and then elevation and area is calculated from the computed storages where possible. A similar procedure is also used with the `Elevation-Area-Discharge` storage method.

You must select appropriate functions to define the selected storage method. For example, if you select the `Elevation-Storage-Discharge` method, you must select an elevation-storage and a storage-discharge paired data function. Appropriate selection lists will be shown directly under the storage method selection list. Any necessary paired data functions must be defined in the paired data manager before they can be used in the reservoir. Choose an appropriate function in each selection list. If you wish, you can use a chooser by clicking the paired data button next to the selection list. A chooser will open that shows all of the paired data functions of that type. Click on a function to view its description.

### ***Initial Condition***

The initial condition sets the amount of storage in the reservoir at the beginning of a simulation. Therefore, the simplest option is to specify the `Storage` as a volume of water in the reservoir. For convenience, other options are also provided. The `Inflow=Outflow` method takes the inflow to the reservoir at the beginning of the simulation, and uses the storage-discharge curve to determine the storage required to produce that same flowrate as the outflow from the reservoir. Some storage methods permit the specification of `Elevation` as the initial condition. In this case, the elevation provided by the user is used to interpolate a storage value from the elevation-storage curve. Other storage methods permit the specification of `Discharge` as the initial condition. In this case, the storage is interpolated from the storage-discharge curve. The initial condition options depend on the selected storage method and are shown in Table 21.

*Table 21. Available initial condition options for different storage methods used with the outflow curve routing method.*

<b>Storage Method</b>	<b>Available Initial Conditions</b>
Storage-Discharge	Discharge, storage, inflow = outflow
Elevation-Storage-Discharge	Discharge, storage, elevation, inflow = outflow
Elevation-Area-Discharge	Discharge, elevation, inflow = outflow

## **Specified Release Routing**

The specified release routing method is designed to model reservoirs where the total discharge is known for each time interval of a simulation. Usually this method is used when the discharge is either observed or completely specified by an external decision process. The method can then be used to preserve the specified release and track the storage using the inflow, outflow, and conservation of mass.

### **Storage Method**

There are two different options for specifying the storage relationship, as shown in Figure 166. The first option is the `Elevation-Storage` choice. The user must select an elevation-storage curve from the available curves in the Paired Data Manager. After the routing is complete, the program will compute the elevation and storage for each time interval. The second option is the `Elevation-Area` choice, which requires the selection of an elevation-area curve from the available curves in the Paired Data Manager. With this choice, the program automatically transforms the elevation-area curve into an elevation-storage curve using the conic formula. After the routing is complete, the program will compute the elevation, surface area, and storage for each time interval.

You must select an appropriate function to define the selected storage method. For example, if you select the `Elevation-Storage` method you must select an appropriate elevation-storage paired data function that defines the storage characteristics of the reservoir. The appropriate selection list will be shown directly under the storage method selection list. The necessary paired data functions must be defined in the paired data manager before they can be used in the reservoir. Choose an appropriate function in each selection list. If you wish, you can use a chooser by clicking the paired data button next to the selection list. A chooser will open that shows all of the paired data functions of that type. Click on a function to view its description.

## Initial Condition

The initial condition sets the amount of storage in the reservoir at the beginning of a simulation. The choices depend on the method selected for specifying the storage characteristics of the reservoir. When the `Elevation-Storage` method is selected, you may choose to specify the initial elevation or the initial storage. When the `Elevation-Area` method is selected, you must specify an initial elevation.

## Discharge Gage Selection

You must select a discharge time-series gage as the outflow from the reservoir. The gage should record the discharge to use for each time interval of the simulation. If there is missing data in the record and the basin model options are set to replace missing data, a zero flow rate will be substituted for each missing data value. If the basin model is not set to replace missing data, any missing data will cause the simulation to stop and an error message will be displayed.

The time-series discharge gage must be defined in the time-series manager before it can be used in the reservoir editor (Figure 166). Selecting the correct gage is performed on the *Component Editor* for the reservoir element. Access the *Component Editor* by clicking the reservoir element icon on the "Components" tab of the *Watershed Explorer*. You can also access the *Component Editor* by clicking on the element icon in the basin map, if the map is currently open.

The screenshot shows the 'Reservoir Options' dialog box. The 'Basin Name' is 'Prj Alt 1' and the 'Element Name' is 'Salmon Falls Dam'. The 'Description' field is empty. The 'Downstream' dropdown is set to 'Lower Salmon'. The 'Method' dropdown is set to 'Specified Release'. The 'Storage Method' dropdown is set to 'Elevation-Storage'. The '\*Elev-Stor Function' dropdown is set to 'Salmon Falls Store'. The 'Initial Condition' dropdown is set to 'Elevation'. The '\*Initial Elevation (M)' text box contains the value '6.37'. The '\*Discharge Gage' dropdown is set to 'Salmon Tailwater Gage'. The 'Max Release (M3/S)' and 'Max Capacity (1000 M3)' text boxes are empty. There are several icons on the right side of the dialog, including a plus sign, a save icon, a list icon, a chart icon, and a refresh icon.

Figure 166. Reservoir component editor using the specified release routing method with an elevation-storage function.

### ***Discharge Limit Options***

The maximum release setting is optional. It will cause a warning message during a simulation if the specified release exceeds the setting value. The specified release from the time-series gage record will always be discharged from the reservoir. However, the warning will occur when the specified release exceeds the optional maximum release value.

The maximum capacity setting is optional. It will cause a warning message during a simulation if the calculated storage exceeds the setting value. The storage is calculated for each time interval using conservation of mass. The storage at the end of the previous time interval, and the inflow volume and specified outflow volume for the current time interval, are used to calculate the storage at the end of the current time interval. The calculated storage will not be changed when it exceeds the setting value. However, the warning message will occur when the calculated storage exceeds the setting value.

### ***Outflow Structures Routing***

The outflow structures routing method is designed to model reservoirs with a number of uncontrolled outlet structures. For example, a reservoir may have a spillway and several low-level outlet pipes. While there is an option to include gates on spillways, the ability to control the gates is extremely limited at this time. There are currently no gates on outlet pipes. However, there is an ability to include a time-series of releases in addition to the uncontrolled releases from the various structures. An external analysis may be used to develop the additional releases based on an operations plan for the reservoir.

Additional features in the reservoir for culverts and pumps allow the simulation of interior ponds. This class of reservoir often appears in urban flood protection systems. A small urban creek drains to a collection pond adjacent to a levee where flood waters collect. When the main channel stage is low, water in the collection pond can drain through culverts into the main channel. Water must be pumped over the levee when the main channel stage is high.

### ***Storage Method***

There are two different options for specifying the storage relationship. The first option is the `Elevation-Storage` choice, as shown in Figure 167. The user must select an elevation-storage curve from the available curves in the Paired Data Manager. After the routing is complete, the program will compute the elevation and storage for each time interval. The second option is the `Elevation-Area` choice,

which requires the selection of an elevation-area curve from the available curves in the Paired Data Manager. With this choice, the program automatically transforms the elevation-area curve into an elevation-storage curve using the conic formula. After the routing is complete, the program will compute the elevation, surface area, and storage for each time interval.

The screenshot shows the 'Reservoir Options' dialog box. The 'Basin Name' is 'Prj Alt 1' and the 'Element Name' is 'Salmon Falls Dam'. The 'Description' field is empty. The 'Downstream' is set to 'Lower Salmon'. The 'Method' is 'Outflow Structures'. The 'Storage Method' is 'Elevation-Storage'. The '\*Elev-Stor Function' is 'Salmon Falls Store'. The 'Initial Condition' is 'Elevation'. The '\*Initial Elevation (M)' is 29.3. The 'Main Tailwater' is 'Fixed Stage'. The '\*Stage (M)' is 1.2. The 'Auxiliary' is '--None--'. The 'Time Step Method' is 'Automatic'. The 'Outlets' are 3, 'Spillways' are 1, and 'Dam Tops' are 1. 'Pumps' are 0. 'Dam Break', 'Dam Seepage', 'Release', and 'Evaporation' are all set to 'No'.

Figure 167. Reservoir component editor using the outflow structures routing method with three outlets, one spillway, and one dam top representing an emergency spillway.

You must select an appropriate function to define the selected storage method. For example, if you select the `Elevation-Storage` method you must select an appropriate elevation-storage paired data function that defines the storage characteristics of the reservoir. The appropriate selection list will be shown directly under the storage method selection list. Any necessary paired data functions must be defined in the paired data manager before they can be used in the reservoir. Choose an appropriate function in each selection list. If you wish, you can use a chooser by clicking the paired data button next to

the selection list. A chooser will open that shows all of the paired data functions of that type. Click on a function to view its description.

### **Initial Condition**

The initial condition sets the amount of storage in the reservoir at the beginning of a simulation. Therefore, the simplest option is to specify the `Storage` as a volume of water in the reservoir. For convenience, other options are also provided. The `Inflow=Outflow` method takes the inflow to the reservoir at the beginning of the simulation, and determines the pool elevation necessary to cause that outflow through the outlet structures. The pool elevation is then used in the elevation-storage curve to determine the matching storage. The pool `Elevation` method can also be selected for the initial condition. In this case, the elevation provided by the user is used to interpolate a storage value from the elevation-storage curve. The initial condition options depend on the selected storage method and are shown in Table 22.

*Table 22. Available initial condition options for different storage methods used with the outlet structures routing method.*

<b>Storage Method</b>	<b>Available Initial Conditions</b>
Elevation-Storage	Elevation, storage, inflow = outflow
Elevation-Area	Elevation, inflow = outflow

### **Tailwater Method**

The selected tailwater method determines how submergence will be calculated for the individual structures specified as part of the reservoir. When a structure is submerged, the discharge through the structure will decrease in accordance with the physics of the structure and the tailwater elevation for each time interval. Only one tailwater method can be selected and it is applied to all structures specified as part of the reservoir.

The `Assume None` method is used in cases where reservoir tailwater has no affect on the reservoir outflow.

The `Reservoir Main Discharge` method is typically used with reservoirs that span the stream channel and are not influenced by backwater from downstream sources. For such cases, the tailwater below the reservoir only comes from the reservoir releases. A rating curve defined by an elevation-discharge paired data function must be selected to convert reservoir outflow to stage. The elevation-discharge function must be defined before it can be used in the reservoir.

Choose an appropriate function in the selection list or use a chooser by



clicking the paired data button next to the selection list. The rating curve should be specified in the same vertical datum as the function used to describe the storage characteristics of the reservoir.

The `Downstream Of Main Discharge` method is typically used with reservoirs that represent an interior pond or pump station, and the outflow from the reservoir will be a significant impact on the downstream stage. In this case, the outflow from the reservoir is combined with all other inflows to the element downstream of the reservoir. That combined inflow is used in combination with a rating curve to determine the stage for the reservoir tailwater. The elevation-discharge function for the rating curve must be defined in the paired data manager before it can be used in the reservoir. Choose an appropriate function in the selection list or use a chooser by clicking the paired data button next to the selection list. The rating curve should be specified in the same vertical datum as the function used to describe the storage characteristics of the reservoir.

The `Specified Stage` method is typically used with reservoirs that represent an interior pond or pump station, and the outflow from the reservoir will have minimal affect on the downstream stage. In this case, the outflow from the reservoir is adjusted for submergence based on the stage specified in a stage time-series gage. The gage must be defined in the time-series data manager before it can be used in the reservoir. Choose an appropriate gage in the selection list or use a chooser by clicking the gage data button next to the selection list. The stage should be specified in the same vertical datum as the function used to describe the storage characteristics of the reservoir.

The `Fixed Stage` method is typically used with reservoirs that represent an interior pond or pump station. The same stage is used for all time intervals in a simulation. In this case, the outflow from the reservoir is adjusted for submergence based on the specified stage.

### ***Auxiliary Discharge Location***

All reservoirs have a primary discharge to the downstream. Flow through outlets, spillways, and other structures leaves the reservoir and enters some type of channel. However, some reservoirs also have an auxiliary discharge in addition to the primary discharge. The flow exiting through the auxiliary discharge location does not enter the same channel as the main discharge. The auxiliary discharge may be an emergency spillway that enters a secondary channel that eventually enters the main downstream channel. The auxiliary discharge could also be a withdrawal for urban consumptive use or possibly an agricultural irrigation canal.

Each structure added to the reservoir can be designated to discharge to the `Main` or `Auxiliary` direction. The default is for a structure to discharge in the main direction. Optionally, one or more outlet structures can be set to discharge in the auxiliary direction. Both the main and auxiliary locations use separate tailwater methods. An appropriate tailwater selection should be made for the auxiliary location if it will be used. The selection of tailwater method is independent for the two directions so they may be the same or different. When a rating curve is used for the tailwater method, the rating curve should be appropriate for the main or auxiliary location where it is selected for use.

### ***Time Step Control***

The `Outflow Structures` routing method uses an adaptive time step algorithm. The time step specified in the *Control Specifications* is used during periods of a simulation when the reservoir pool elevation is changing slowly. However, under conditions when the pool elevation is changing rapidly, such as during a dam break, a shorter time step is used. The adaptive time step algorithm automatically selects an interval based on the rates at which the pool elevation, storage, and outflow are changing. Results are always computed at the time interval specified in the *Control Specifications*. Any adaptive steps taken between these time intervals are used internally to obtain the solution but are not stored for later use or display. The adaptive time step algorithm obtains very good solutions of the pool elevation and outflow. However, many more calculations may be necessary to obtain the results. For preliminary simulations, especially those with a long time window, it may be advantageous to disable the adaptive time step portion of the algorithm. This can be accomplished in the reservoir component editor (Figure 167) by selecting the `Simulation Interval` time step method. Simulations with a short time window or final simulations with a long time window should use the `Automatic Adaption` time step method to get the best possible precision in the results.

### ***Outlets***

Outlets can only be included in reservoirs using the `Outflow Structures` routing method. Outlets typically represent structures near the bottom of the dam that allow water to exit in a controlled manner. They are often called gravity outlets because they can only move water when the head in the reservoir is greater than the head in the tailwater. Up to 10 independent outlets can be included in the reservoir. Select the number of outlets you wish to include. An icon for each outlet will be added to the reservoir icon in the *Watershed Explorer*. You will need to click on the individual outlet icon to enter

parameter data for it. There are two different methods for computing outflow through an outlet: culvert or orifice.

### **Culvert Outlet**

The culvert outlet allows for partially full or submerged flow through a culvert with a variety of cross-sectional shapes. It can account for inlet controlled outflow or outlet control. A typical culvert outlet is shown in Figure 168.

The screenshot shows a software interface for editing an outlet. At the top, there are three tabs: 'Reservoir', 'Outlet 1', and 'Options'. The 'Outlet 1' tab is active. Below the tabs, the following information is displayed:

- Basin Name:** Prj Alt 1
- Element Name:** Salmon Falls Dam
- Method:** Culvert Outlet (selected in a dropdown menu)
- Direction:** Main (selected in a dropdown menu)
- Number Barrels:** 1 (selected in a spinner box)
- Solution Method:** Automatic (selected in a dropdown menu)
- Shape:** Circular (selected in a dropdown menu)
- Chart:** 3: Concrete Pipe Culvert; Beveled Ring Entrance (selected in a dropdown menu)
- Scale:** 2(B): Large bevel: b/D 0.083; a/D 0.125; c/D ... (selected in a dropdown menu)
- \*Length (M):** 18.2
- \*Diameter (M):** 2.05
- \*Inlet Elevation (M):** 10.2
- \*Entrance Coefficient:** 0.2
- \*Outlet Elevation (M):** 9.8
- \*Exit Coefficient:** 1.0
- \*Mannings n:** 0.011

Figure 168. Outlet editor with the culvert method selected.

You must select a solution method for the culvert: inlet control, outlet control, or automatic. You may select `Inlet Control` if it is known that at all times during a simulation the culvert outflow will be controlled by a high pool elevation in the reservoir. You may likewise select `Outlet Control` if it is known that at all times the culvert outflow will be controlled by a high tailwater condition. In general it is best to select `Automatic` control and the program will automatically determine the controlling inlet or outlet condition.

You must select the number of identical barrels. This can be used to specify several culvert outlets that are identical in all parameters. There can be up to 10 identical barrels.

The shape specifies the cross-sectional shape of the culvert: circular, semi circular, elliptical, arch, high-profile arch, low-profile arch, pipe arch, box, or con span. The shape you choose will determine some of the remaining parameters in the *Component Editor*. The parameters you will need to enter are shown in Figure 168.

The chart specifies the FHWA chart identification number. Only the charts that apply to the selected shape will be shown in the selection list (Figure 168).

The scale specifies the FHWA scale identification number. Only the scales that apply to the selected chart number will be shown in the selection list.

*Table 23. Listing of which parameters are required for each cross section shape.*

<b>Cross Section Shape</b>	<b>Diameter</b>	<b>Rise</b>	<b>Span</b>
Circular	X		
Semi Circular	X		
Elliptical		X	X
Arch		X	X
High-Profile Arch			X
Low-Profile Arch			X
Pipe Arch		X	X
Box		X	X
Con Span		X	X

The length of the culvert must be specified. This should be the overall length of the culvert including any projection at the inlet or outlet.

The inlet elevation must be specified as the invert elevation at the bottom of the culvert on the inlet side. The inlet side is always assumed to be in the reservoir pool. This should be measured in the same vertical datum as the paired data functions defining the storage characteristics of the reservoir.

The entrance coefficient describes the energy loss as water moves into the inlet of the culvert. Values may range from 0.2 up to 1.0.

The exit coefficient describes the energy loss that occurs when water expands as it leaves the culvert outlet. Typically the value is 1.0.

The outlet elevation must be specified as the invert elevation at the bottom of the culvert on the outlet side. The outlet side is always assumed to be in the reservoir tailwater. This should be measured in

the same vertical datum as the paired data functions defining the storage characteristics of the reservoir.

A Manning's  $n$  value should be entered that describes the roughness in the culvert. At this time, the same  $n$  value must be used for the entire length of the culvert, as well as the entire top, sides, and bottom.

### Orifice Outlet

The orifice outlet assumes sufficient submergence on the outlet for orifice flow conditions to dominate. It should not be used to represent an outlet that may flow only partially full. The inlet of the structure should be submerged at all times by a depth at least 0.2 times the diameter. A typical orifice outlet editor is shown in Figure 169.

Basin Name: Prj Alt 1	
Element Name: Salmon Falls Dam	
Method:	Orifice Outlet
Direction:	Main
Number Barrels:	1
*Center Elevation (M)	10.71
*Area (M2)	0.8667
*Coefficient:	0.8

Figure 169. Outlet editor with the orifice method selected.

You must select the number of identical barrels. This can be used to specify several culvert outlets that are identical in all parameters. There can be up to 10 identical barrels.

The center elevation specifies the center of the cross-sectional flow area. This should be measured in the same vertical datum as the paired data functions defining the storage characteristics of the reservoir. It is used to compute the head on the outlet, so no flow will be released until the reservoir pool elevation is above this specified elevation.

The cross-sectional flow area of the outlet must be specified. The orifice assumptions are independent of the shape of the flow area.

The dimensionless discharge coefficient must be entered. This parameter describes the energy loss as water exits the reservoir through the outlet.

## Spillways

Spillways can only be included in reservoirs using the `Outflow Structures` routing method. Spillways typically represent structures at the top of the dam that allow water to go over the dam top in a controlled manner. Up to 10 independent spillways can be included in the reservoir. Select the number of spillways you wish to include. An icon for each spillway will be added to the reservoir icon in the *Watershed Explorer*. You will need to click on the individual outlet icon to enter parameter data for it. There are three different methods for computing outflow through a spillway: broad-crested, ogee, and user specified. The broad-crested and ogee methods may optionally include gates. If no gates are selected, then flow over the spillway is unrestricted. When gates are included, the flow over the spillway will be controlled by the gates. Up to 10 independent gates may be included on a spillway.

### Broad-Crested Spillway

The broad-crested spillway allows for controlled flow over the top of the reservoir according to the weir flow assumptions. A typical broad-crested spillway editor is shown in Figure 170.

The crest elevation of the spillway must be specified. This should be measured in the same vertical datum as the paired data functions defining the storage characteristics of the reservoir.

The screenshot shows a software window titled 'Spillway 1' with three tabs: 'Reservoir', 'Spillway 1', and 'Options'. The 'Spillway 1' tab is active. The interface displays the following information:

- Basin Name:** Prj Alt 1
- Element Name:** Salmon Falls Dam
- Method:** Broad-Crested Spillway (selected in a dropdown menu)
- Direction:** Main (selected in a dropdown menu)
- \*Elevation (M):** 26.4
- \*Length (M):** 24.0
- \*Coefficient (M<sup>0.5</sup>/S):** 1.48
- Gates:** 0 (with a small up/down arrow icon)

Figure 170. Spillway editor with the broad-crested method selected.

The length of the spillway must be specified. This should be the total width through which water passes.

The discharge coefficient accounts for energy losses as water enters the spillway, flows through the spillway, and eventually exits the spillway. Depending on the exact shape of the spillway, typical values

range from 1.10 to 1.66 in System International units (2.0 to 3.0 US Customary units).

### Ogee Spillway

The ogee spillway allows for controlled flow over the top of the reservoir according to the weir flow assumptions. However, the discharge coefficient in the weir flow equation is automatically adjusted when the upstream energy head is above or below the design head. A typical ogee spillway editor is shown in Figure 171.

The screenshot shows a software interface for editing a spillway. At the top, there are three tabs: 'Reservoir', 'Spillway 1', and 'Options'. The 'Spillway 1' tab is active. Below the tabs, the following information is displayed:

- Basin Name:** Prj Alt 1
- Element Name:** Salmon Falls Dam
- Method:** Ogee Spillway (selected in a dropdown menu)
- Direction:** Main (selected in a dropdown menu)
- Abutments:** 2 (selected in a dropdown menu)
- Abutment Type:** Concrete (selected in a dropdown menu)
- \*Approach Depth (M):** 4.88
- \*Approach Loss (M):** 0.04
- \*Crest Elevation (M):** 14.2
- \*Crest Length (M):** 24.0
- \*Apron Elevation (M):** 3.2
- \*Apron Length (M):** 24.0
- \*Design Head (M):** 1.75
- Gates:** 0 (selected in a dropdown menu)

Figure 171. Spillway editor with the ogee method selected.

The ogee spillway may be specified with concrete or earthen abutments. These abutments should be the dominant material at the sides of the spillway above the crest. The selected material is used to adjust energy loss as water passes through the spillway. The spillway may have one, two, or no abutments depending on how the spillway or spillways in a reservoir are conceptually represented.

The ogee spillway is assumed to have an approach channel that moves water from the main reservoir to the spillway. If there is such an approach channel, you must specify the depth of the channel, and the energy loss that occurs between the main reservoir and the spillway. If there is no approach channel, the depth should be the difference between the spillway crest and the bottom of the reservoir, and the loss should be zero.

The crest elevation of the spillway must be entered. This should be measured in the same vertical datum as the paired data functions defining the storage characteristics of the reservoir.

The crest length of the spillway must be specified. This should be the total width through which water passes.

The apron elevation is the elevation at the bottom of the ogee spillway structure. This should be measured in the same vertical datum as the paired data functions defining the storage characteristics of the reservoir.

The apron width must be specified. This should be the total width of the spillway bottom.

The design head is the total energy head for which the spillway is designed. The discharge coefficient will be automatically calculated when the head on the spillway departs from the design head.

### **Specified Spillway**

The user-specified spillway can be used to represent spillways with flow characteristics that cannot be represented by the broad-crested or ogee weir assumptions. The user must create an elevation-discharge curve that represents the spillway discharge as a function of reservoir pool elevation. At this time there is no ability to include submergence effects on the spillway discharge. Therefore the user-specified spillway method should only be used for reservoirs where the downstream tailwater stage cannot affect the discharge over the spillway. A typical user-specified spillway editor is shown in Figure 172.

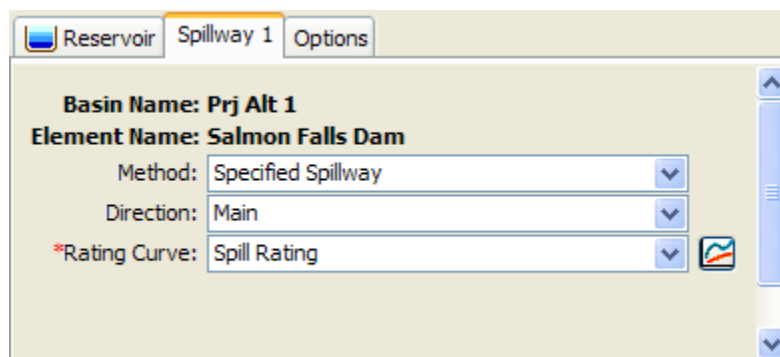

Figure 172. Spillway editor with the user-specified method selected.

The rating curve describing flow over the spillway must be selected. Before it can be selected it must be created in the *Paired Data Manager* as an elevation-discharge function. The function must be calculated external to the program on the basis of advanced spillway hydraulics or experimentation.



## Spillway Gates

Spillway gates are an optional part of specifying the configuration of a spillway. They may be included on either broad-crested or ogee spillways. The number of gates to use for a spillway is specified on the spillway editor (Figure 170 and Figure 171). An icon for each gate will be added to the spillway icon under the reservoir icon in the *Watershed Explorer*. You will need to click on the individual gate icon to enter parameter data for it. There are two different methods for computing outflow through a gated spillway: sluice or radial. In both cases you may specify the number of identical units; each identical unit has exactly the same parameters, including how the gate is controlled.

### Sluice Gate

A sluice gate moves up and down in a vertical plane above the spillway in order to control flow. The water passes under the gate as it moves over the spillway. For this reason it is also called a vertical gate or underflow gate. The editor is shown in Figure 173.

Basin Name: Prj Alt 1	
Element Name: Salmon Falls Dam	
Spillway Name: Spillway 1	
Method:	Sluice Gate
Number Identical:	1
*Width (M)	10.0
*Gate Coefficient:	0.62
*Orifice Coefficient:	0.80
Control Method:	Fixed Opening
*Opening (M)	1.55

Figure 173. Sluice gate editor for spillways.

The width of the sluice gate must be specified. It should be specified as the total width of an individual gate.

The gate coefficient describes the energy losses as water passes under the gate. Typical values are between 0.5 and 0.7 depending on the exact geometry and configuration of the gate.

The orifice coefficient describes the energy losses as water passes under the gate and the tailwater of the gate is sufficiently submerged. A typical value for the coefficient is 0.8.

## Radial Gate

A radial gate rotates above the spillway with water passing under the gate as it moves over the spillway. This type of gate is also known as a tainter gate. The editor is shown in Figure 174.

Basin Name:	Prj Alt 1
Element Name:	Salmon Falls Dam
Spillway Name:	Spillway 1
Method:	Radial Gate
Number Identical:	6
*Width (M)	10.0
*Gate Coefficient:	0.62
*Orifice Coefficient:	0.8
*Trunnion Height (M)	4.0
*Trunnion Exponent:	0.160
*Opening Exponent:	0.721
*Head Exponent:	0.620
Control Method:	Fixed Opening
*Opening (M)	1.55

Figure 174. Radial gate editor for spillways.

The width of the radial gate must be specified. It should be specified as the total width of an individual gate.

The gate coefficient describes the energy losses as water passes under the gate. Typical values are between 0.5 and 0.7 depending on the exact geometry and configuration of the gate.

The orifice coefficient describes the energy losses as water passes under the gate and the tailwater of the gate is sufficiently submerged. A typical value for the coefficient is 0.8.

The pivot point for the radial gate is known as the trunnion. The height of the trunnion above the spillway must be entered.

The trunnion exponent is part of the specification of the geometry of the radial gate. A typical value is 0.16.

The gate opening exponent is used in the calculation of flow under the gate. A typical value is 0.72.

The head exponent is used in computing the total head on the radial gate. A typical value is 0.62.

## **Controlling Spillway Gates**

An important part of defining gates on a spillway is the specification of how each gate will operate. It is rare that a gate is simply opened a certain amount and then never changed. Usually gates are changed on a regular basis in order to maintain the storage in the reservoir pool at targets; usually seasonal targets will be defined in the reservoir regulation manual. Under some circumstances, the gate operation may be changed to prevent flooding or accommodate other special concerns. At this time there is only one method for controlling spillway gates but additional methods will be added in the future.

The `Fixed Opening` control method only accommodates a single setting for the gate. The distance between the spillway and the bottom of the gate is specified. The same setting is used for the entire simulation time window.

## **Dam Tops**

Dam tops can only be included in reservoirs using the `Outflow Structures` routing method. These typically represent the top of the dam, above any spillways, where water goes over the dam top in an uncontrolled manner. In some cases it may represent an emergency spillway. Up to 10 independent dam tops can be included in the reservoir. Select the number of dam tops you wish to include. An icon for each dam top will be added to the reservoir icon in the *Watershed Explorer*. You will need to click on the individual dam top icon to enter parameter data for it. There are two different methods for computing outflow through a dam top: level or non-level.

### **Level Dam Top**

The level dam top assumes flow over the dam can be represented as a broad-crested weir. The calculations are essentially the same as for a broad-crested spillway. They are included separately mostly for conceptual representation of the reservoir structures. A typical level dam top is shown in Figure 175.

Basin Name:	Prj Alt 1
Element Name:	Salmon Falls Dam
Method:	Level Overflow
Direction:	Main
*Elevation (M)	30.0
*Length (M)	28.00
*Coefficient (M <sup>0.5</sup> /S)	1.48

Figure 175. Dam top editor with the level overflow method selected.

The crest elevation of the dam top must be specified. This should be measured in the same vertical datum as the paired data functions defining the storage characteristics of the reservoir.

The length of the dam top must be specified. This should be the total width through which water passes, excluding any amount occupied by spillways if any are included.

The discharge coefficient accounts for energy losses as water approaches the dam top and flows over the dam. Depending on the exact shape of the dam top, typical values range from 1.10 to 1.66 in System International units (2.0 to 3.0 US Customary units).

### **Non-Level Dam Top**

The non-level dam top assumes that the top of the dam can be well-represented by a cross section with eight station-elevation pairs. A separate flow calculation is carried out for each segment of the cross section. The broad-crested weir assumptions are made for each segment. A typical non-level dam top is shown in Figure 176.

A cross section must be selected which describes the shape of the top of the dam with a simplified eight point shape. From abutment to abutment of the dam, but should not include any spillways that may be included. It may be necessary to use multiple dam tops to represent the different sections of the dam top between spillways. The cross section should extend from the dam top up to the maximum water surface elevation that will be encountered during a simulation. The cross section must be defined in the paired data manager before it can be used in the reservoir element.

The discharge coefficient accounts for energy losses as water approaches the dam top and flows over the dam. The same value is used for all segments of the dam top. Typical values range from 2.6 to 4.0 depending on the exact shape of the dam top.

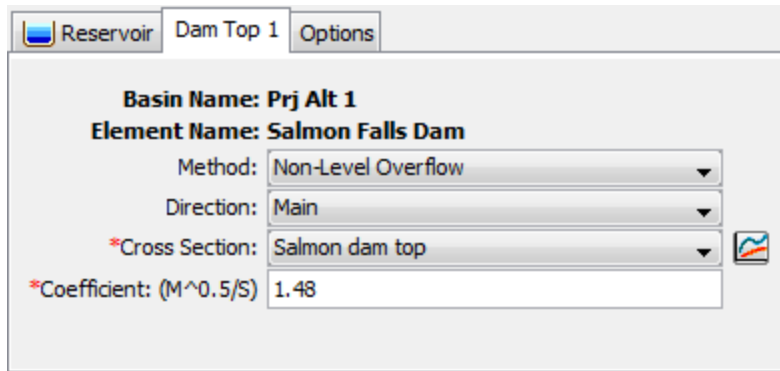

Figure 176. Dam top editor with the non-level overflow method selected.

## Pumps

Pumps can only be included in reservoirs using the `Outflow Structures` routing method. These typically represent pumps in interior ponds or pump stations that are intended to move water out of the reservoir and into the tailwater when gravity outlets alone cannot move sufficient water. Up to 10 independent pumps can be included in the reservoir. Select the number of pumps you wish to include. An icon for each pump will be added to the reservoir icon in the *Watershed Explorer*. You will need to click on the individual pump icon to enter parameter data for it. There is only one method for computing outflow through a pump: head-discharge pump.

### Head-Discharge Pump

The head-discharge pump is designed to represent low-head, high-flow situations. This means that the pump is designed for high flow rates against a relatively small head. The pump can be controlled to come on and shut off as the reservoir pool elevation changes. A typical head-discharge pump is shown in Figure 177.

The number of identical units must be specified. This allows data to be entered only once when there are multiple pump units with exactly the same parameters.

Figure 177. Pump editor with the head-discharge method selected.

The intake elevation defines the elevation in the reservoir pool where the pump takes in water. This should be measured in the same vertical datum as the paired data functions defining the storage characteristics of the reservoir.

The line elevation defines the highest elevation in the pressure line from the pump to the discharge point. This should be measured in the same vertical datum as the paired data functions defining the storage characteristics of the reservoir.

You must specify the elevation when the pump turns on. This should be measured in the same vertical datum as the paired data functions defining the storage characteristics of the reservoir. Once the pump turns on, it will remain on until the reservoir pool elevation drops below the trigger elevation to turn the pump off.

You must specify the elevation when the pump turns off. This should be measured in the same vertical datum as the paired data functions defining the storage characteristics of the reservoir. This elevation must be lower than the elevation at which the pump turns on.

The specification of a minimum rest time is optional. If it is used, once a pump shuts off it must remain off the specified minimum rest time even if the reservoir pool elevation reaches the trigger elevation to turn the pump on.

The specification of a minimum run time is optional. If it is used, once a pump turns on it must remain on the specified minimum run time

even if the reservoir pool elevation drops below the trigger elevation to turn the pump off. The only exception is if the pool elevation drops below the intake elevation, then the pump will shut off even though the minimum run time is not satisfied.

The equipment loss includes all energy losses between the intake and discharge points, including the pump itself. This loss is added to the head difference due to reservoir pool elevation and tailwater elevation to determine the total energy against which the pump must operate.

The head-discharge curve describes the capacity of the pump as a function of the total head. Total head is the head difference due to reservoir pool elevation and tailwater elevation, plus equipment loss. A curve must be defined as an elevation-discharge function in the paired data manager before it can be selected for a pump in the reservoir. You can press the paired data button next to the selection list to use a chooser. The chooser shows all of the available elevation-discharge functions in the project. Click on a function to view its description.

### **Dam Break**

Dam break can only be included in reservoirs using the `Outflow Structures` routing method. Only one dam break can be included in the reservoir. Choose whether you wish to include dam break. An icon for the dam break will be added to the reservoir icon in the *Watershed Explorer*. You will need to click on the dam break icon to enter parameter data for it. There are two different methods for computing outflow through a dam break: overtop and piping.

#### **Overtop Dam Break**

The overtop dam break (Figure 178) is designed to represent failures caused by overtopping of the dam. These failures are most common in earthen dams but may also occur in concrete arch, concrete gravity, or roller compacted dams as well. The failure begins when appreciable amounts of water begin flowing over or around the dam face. The flowing water will begin to erode the face of the dam. Once erosion begins it is almost impossible to stop the dam from failing. The method begins the failure at a point on the top of the dam and expands it in a trapezoidal shape until it reaches the maximum size. Flow through the expanding breach is modeled as weir flow.

The top elevation is the top of the dam face. The breach may be initiated at a lower elevation than the top depending on the selection of the trigger. This information is used to constrain the top of the breach opening as it grows. It should be measured in the same vertical datum as the paired data functions defining the storage characteristics of the reservoir.

The screenshot shows a software interface for editing dam break parameters. At the top, there are three tabs: 'Reservoir', 'Dam Break', and 'Options'. The 'Dam Break' tab is active. Below the tabs, the 'Basin Name' is 'Prj Alt 1' and the 'Element Name' is 'Salmon Falls Dam'. The 'Method' is set to 'Overtop Breach'. The 'Direction' is 'Main'. The parameters are as follows:

Parameter	Value
*Top Elevation (M)	31.0
*Bottom Elevation (M)	3.5
*Bottom Width (M)	30
*Left Slope (xH:1V)	1.2
*Right Slope (xH:1V)	1.2
*Development Time (HR)	6
Trigger Method	Duration at Elevation
*Trigger Elevation (M)	31.0
*Trigger Duration (HR)	12
Progression Method	Linear

Figure 178. Dam break editor with the overtop breach method selected.

The bottom elevation defines the elevation of the bottom of the trapezoidal opening in the dam face when the breach is fully developed. This should be measured in the same vertical datum as the paired data functions defining the storage characteristics of the reservoir.

The bottom width defines the width of the bottom of the trapezoidal opening in the dam face when the breach is fully developed.

The left side slope is dimensionless and entered as the units of horizontal distance per one unit of vertical distance. The right side slope is likewise dimensionless and entered as the units of horizontal distance per one unit of vertical distance.

The development time defines the total time for the breach to form, from initiation to reaching the maximum breach size. It should be specified in hours.

There are three methods for triggering the initiation of the failure: elevation, duration at elevation, and specific time. Depending on the method you choose, additional parameters will be required. For the `Elevation` method, you will enter an elevation when the failure should start. The breach will begin forming as soon as the reservoir pool elevation reaches that specified elevation. For the `Duration at Elevation` method, you will enter an elevation and duration to define when the failure should start. The reservoir pool will have to remain at or above the specified elevation for the specified duration before the



failure will begin. For the `Specific Time` method, the breach will begin opening at the specified time regardless of the reservoir pool elevation. When specifying an elevation, it should be measured in the same vertical datum as the paired data functions defining the storage characteristics of the reservoir.

The progression method determines how the breach grows from initiation to maximum size during the development time. Select the `Linear` method to have the breach grow in equal increments of depth and width. Select the `Sine Wave` method to have the breach grow quickly in the early part of breach development and more slowly as it reaches maximum size. The speed varies according to the first quarter cycle of a sine wave. Select the `User Curve` method to have the breach grow according to a specified pattern. You will need to select a curve in the selection list, which will show all percentage curves defined in the paired data manager. The independent variable should range from 0 to 100 percent and define the percentage of the development time. The dependent variable should define the percentage opening of the maximum breach size. The function must be monotonically increasing.

### ***Piping Dam Break***

The piping dam break is designed to represent failures caused by piping inside the dam. These failures typically occur only in earthen dams. The failure begins when water naturally seeping through the dam core increases in velocity and quantity enough to begin eroding fine sediments out of the soil matrix. If enough material erodes, a direct piping connect may be established from the reservoir water to the dam face. Once such a piping connect is formed it is almost impossible to stop the dam from failing. The method begins the failure at a point in the dam face and expands it as a circular opening. When the opening reaches the top of the dam, it continues expanding as a trapezoidal shape. Flow through the circular opening is modeled as orifice flow while in the second stage it is modeled as weir flow.

The piping dam break (Figure 179) uses many of the same parameters as the overtop dam break. The top elevation, bottom elevation, bottom width, left slope, and right slope all are used to describe a trapezoidal breach opening that will be the maximum opening in the dam. These are only used once the piping opening transitions to an open breach. The parameters for development time, trigger method, and progression method are also the same for defining when the failure initiates, how long it takes to attain maximum breach opening, and how the breach develops during the development time. The remaining parameters, unique to piping dam break, are described below.

The screenshot shows a software interface for editing dam break parameters. At the top, there are three tabs: 'Reservoir', 'Dam Break', and 'Options'. The 'Dam Break' tab is active. Below the tabs, the following information is displayed:

- Basin Name:** Prj Alt 1
- Element Name:** Salmon Falls Dam
- Method:** Piping Breach (selected in a dropdown menu)
- Direction:** Main (selected in a dropdown menu)
- \*Top Elevation (M):** 31.0
- \*Bottom Elevation (M):** 3.5
- \*Bottom Width (M):** 30
- \*Left Slope (xH: 1V):** 1.2
- \*Right Slope (xH: 1V):** 1.2
- \*Piping Elevation (M):** 18.27
- \*Piping Coefficient:** 0.80
- \*Development Time (HR):** 5.75
- Trigger Method:** Elevation (selected in a dropdown menu)
- \*Trigger Elevation (M):** 28.77
- Progression Method:** Linear (selected in a dropdown menu)

Figure 179 Dam break editor with the piping breach method selected.

The piping elevation indicates the point in the dam where the piping failure first begins to form. This should be measured in the same vertical datum as the paired data functions defining the storage characteristics of the reservoir.

The piping coefficient is used to model flow through the piping opening as orifice flow. As such, the coefficient represents energy losses as water moves through the opening.

### **Dam Seepage**

Dam seepage can only be included in reservoirs using the `Outflow Structures` routing method. Most dams have some water seeping through the face of the dam. The amount of seepage depends on the elevation of water in the dam, the elevation of water in the tailwater, the integrity of the dam itself, and possibly other factors. In some situations, seepage from the pool through the dam and into the tailwater can be a significant source of discharge that must be modeled. Interior ponds may discharge seepage water but in some situations water in the main channel may seep through the levee or dam face and enter the pool. Both of these situations can be represented using the dam seepage structure.

There can only be one dam seepage structure in a reservoir that must represent all sources and sinks of seepage. When water seeps out of

the reservoir, the seepage is automatically taken from the reservoir storage and added to the main tailwater discharge location. This is the mode of seepage when the pool elevation is greater than the tailwater elevation. Seepage into the reservoir happens when the tailwater elevation is higher than the pool elevation. In this mode the appropriate amount of seepage is added to reservoir storage, but it is not subtracted from the tailwater.

### **Tabular Seepage**

The tabular seepage method uses an elevation-discharge curve to represent seepage as shown in Figure 180. Usually the elevation-discharge data will be developed through a geotechnical investigation separate from the hydrologic study. A curve may be specified for inflow seepage from the tailwater toward the pool, and a separate curve selected for outflow seepage from the pool to the tailwater. The same curve may be selected for both directions if appropriate. Any curve used for dam seepage must first be created in the *Paired Data Manager*. If a curve is not selected for one of the seepage directions, then no seepage will be calculated in that direction.

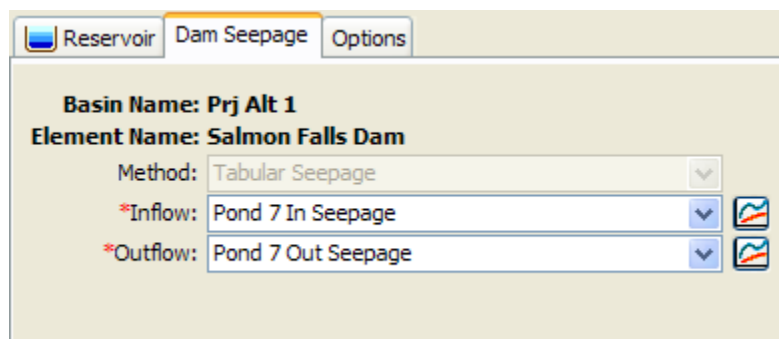

Figure 180. Dam seepage editor showing seepage into a reservoir.

### **Additional Release**

An additional release can only be included in reservoirs using the `Outflow Structures` routing method. In most situations a dam can be properly configured using various outlet structures such as spillways, outlets, etc. The total outflow from the reservoir can be calculated automatically using the physical properties entered for each of the included structures. However, some reservoirs may have an additional release beyond what is represented by the various physical structures. In many cases this additional release is a schedule of managed releases achieved by operating spillway gates. The additional release can be used in combination with other outlet structures to determine the total release from the reservoir.

The additional release that will be specified must be stored as a discharge gage. The appropriate gage can be selected in the editor as

shown in Figure 181. The gage must be defined in the *Time-Series Data Manager* before it can be selected. You can press the time-series data button next to the selection list to use a chooser. The chooser shows all of the available discharge gages in the project. Click on a gage to view its description.

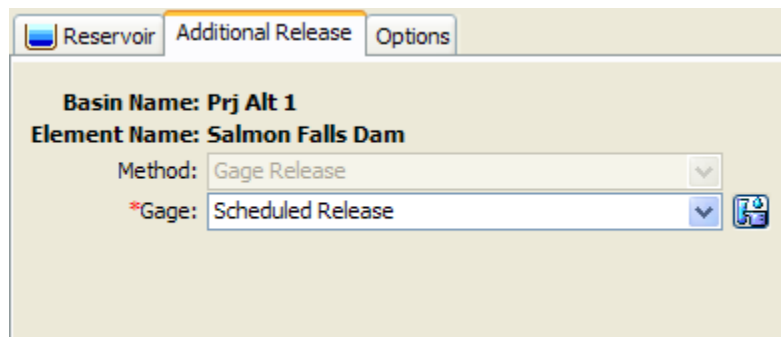

Figure 181. Additional release editor showing a selected discharge gage.

## Evaporation

Evaporation can only be included in reservoirs using the `Outflow Structures` routing method. Additionally, the reservoir must be set to use the `elevation-area` storage option. Water losses due to evaporation may be an important part of the water balance for a reservoir, especially in dry or desert environments. The evaporation losses are different from other structures because they do not contribute to either main or auxiliary outflow. They are accounted separately and available for review with the other time-series results for the reservoir. An evaporation depth is computed for each time interval and then multiplied by the current surface area.

### Monthly Evaporation

The monthly evaporation method can be used to specify a separate evaporation rate for each month of the year, entered as a total depth for the month. The evaporation data must be developed through separate, external analysis and entered as shown in Figure 182.

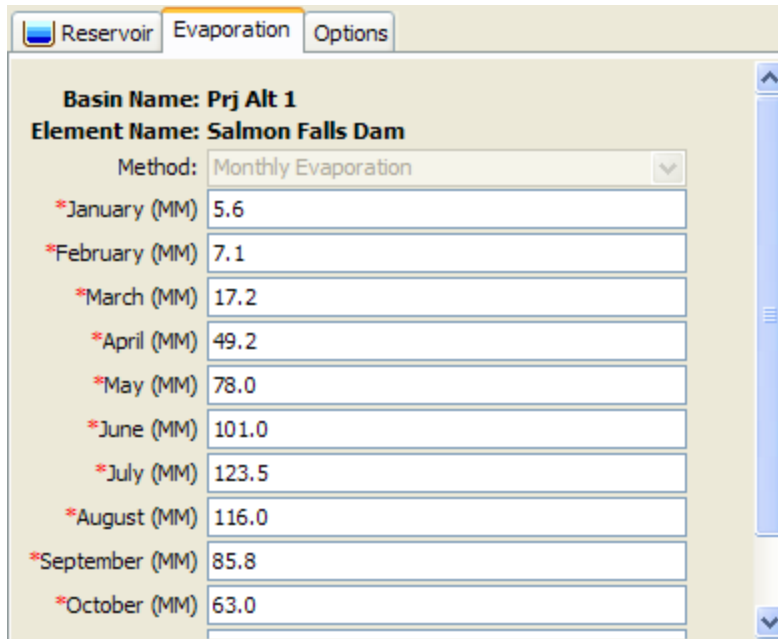

Basin Name: Prj Alt 1  
Element Name: Salmon Falls Dam

Method: Monthly Evaporation

*January (MM)	5.6
*February (MM)	7.1
*March (MM)	17.2
*April (MM)	49.2
*May (MM)	78.0
*June (MM)	101.0
*July (MM)	123.5
*August (MM)	116.0
*September (MM)	85.8
*October (MM)	63.0

Figure 182. Evaporation editor showing the monthly evaporation method for a reservoir.

This Page Left Blank

## CHAPTER 10

## Source, Junction, Diversion, and Sink Elements

Source elements provide a way to add measured inflows to the flow network, or to represent upstream boundary conditions. Junction elements are used in the flow network to combine multiple inflows, often at a confluence. The diversion element is used to represent locations in the flow network where water is withdrawn from the channel, and may be discharged to a canal or stream. Finally, sink elements are used to represent the outlet of a watershed. It is permissible to have more than one outlet in a basin model.

### Source

A source is an element with no inflow, one outflow, and is one of only two ways to produce flow in the basin model. The source can be used to represent boundary conditions to the basin model such as measured outflow from reservoirs or unmodeled headwater regions. The boundary condition can also represent contributing area modeled in a separate basin model. Access the *Component Editor* by clicking the source element icon on the "Components" tab of the *Watershed Explorer* (Figure 183).

Figure 183. Source component editor. All element editors include the basin model and element name, description, and downstream connection. The source editor also has an area and other properties depending on the method.

### Representative Area

Specification of a representative area for the source is optional. If the area is specified, then it will be possible for the program to

automatically compute drainage area at downstream elements. If the area is not specified, then downstream elements will not have a drainage area. When the source represents a region modeled separately, then the area should be equal to the drainage area at the source location in the watershed. When the source is used to represent a spring, inter-basin transfer, or other movement of water, then the area should usually be set to zero.

If you choose to include a representative area, specify the area on the *Component Editor* for the source element (Figure 183). Access the *Component Editor* by clicking the source element icon on the "Components" tab of the *Watershed Explorer*. You can also access the *Component Editor* by clicking on the element icon in the basin map, if the map is currently open.

### **Selecting an Inflow Method**

While a source element conceptually represents a source of inflow to the flow network, the actual calculations are performed by an inflow method contained within the source element. Three methods are currently available for computing the inflow. The source method is selected on the *Component Editor* for the diversion element. Access the *Component Editor* by clicking the source element icon on the "Components" tab of the *Watershed Explorer* (Figure 183). You can also access the *Component Editor* by clicking on the element icon in the basin map, if the map is currently open. You can select an inflow method from the list of three available choices. If you choose the `None` method, the source will have a discharge of exactly zero into the flow network throughout the simulation. Use the selection list to choose the method you wish to use. Each source element may use a different method or several sources may use the same method.

The parameters for the inflow method are presented on a separate *Component Editor* from the source element editor. The "Inflow" editor is always shown next to the "Source" editor. The information shown on the inflow editor will depend on which method is currently selected.

### **Discharge Gage**

When the `Discharge Gage` method is selected for the source, you must select a time-series discharge gage. The gage should record the discharge to use for each time interval during a simulation. If there is missing data in the record and the basin model options are set to replace missing data, a zero flow rate will be substituted for each missing data value. If the basin model is not set to replace missing data, any missing data will cause the simulation to stop and an error message will be displayed.



The time-series discharge gage must be defined in the time-series manager before it can be used in the source element, as shown in Figure 184. Selecting the correct gage is performed on the *Component Editor* for the source element. Access the *Component Editor* by clicking the source element icon on the "Components" tab of the *Watershed Explorer*. You can also access the *Component Editor* by clicking on the element icon in the basin map, if the map is currently open.

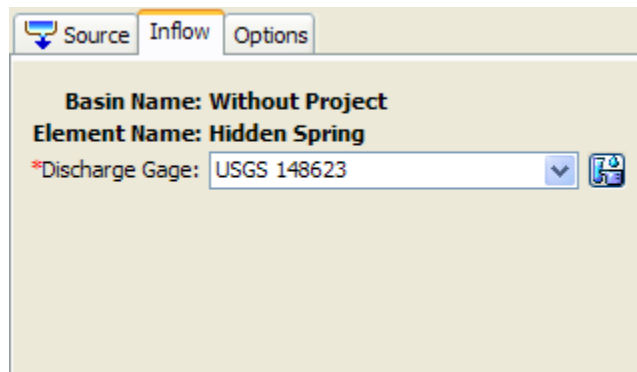

Figure 184. Selecting a discharge gage at a source.

### Constant Flow

When the "Constant Flow" method is selected for the source, you must enter a flow rate. The same flow rate is used for all time steps during a simulation. Specify the flow rate on the *Component Editor* for the source element. Access the *Component Editor* by clicking the source element icon on the "Components" tab of the *Watershed Explorer* (Figure 185). You can also access the *Component Editor* by clicking on the element icon in the basin map, if the map is currently open.

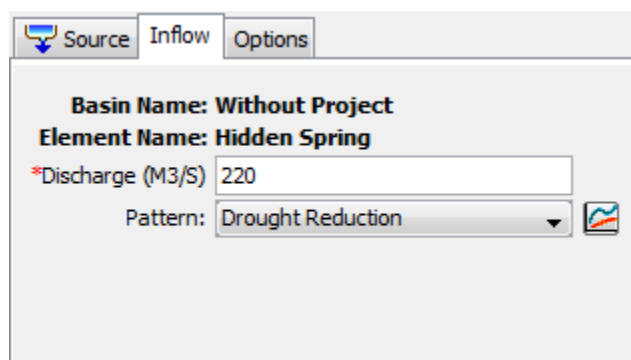

Figure 185. Source editor using the constant flow method.

An annual adjustment pattern is optional. Without a specified annual pattern, the same discharge value is used for every time interval in the simulation. When a pattern is specified, the discharge value is multiplied by the percentage found in the annual pattern for each time interval in the simulation. The annual pattern provides a percentage

that varies throughout the year. The percent annual pattern must be defined in the paired data manager before it can be used in the source element.

## Junction

A junction is an element with one or more inflows and only one outflow. All inflow is added together to produce the outflow by assuming zero storage at the junction. It is usually used to represent a river or stream confluence.

The junction element does not have any special data or properties; it only has the standard *Component Editor* used by all elements. Access the *Component Editor* by clicking the junction element icon on the "Components" tab of the *Watershed Explorer* (Figure 186). You can also access the *Component Editor* by clicking on the element icon in the basin map, if the map is currently open.

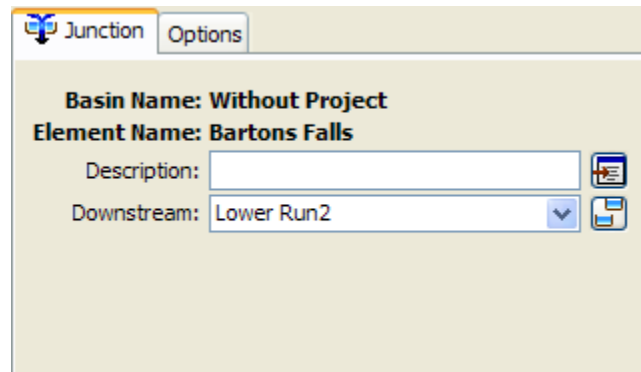

Figure 186. Junction component editor.

## Diversion

A diversion is an element with two outflows, main and diverted, and one or more inflows. Inflow comes from other elements in the basin model. If there is more than one inflow, all inflow is added together before computing the outflows. Six methods are available for computing the diverted flow that will be taken out of the channel. All flow that is not diverted becomes the main outflow. Diverted flow can be connected to an element that is computationally downstream. The diversion can be used to represent weirs or pump stations that divert flow into canals or off-stream storage. The diversion element includes optional properties for limiting the amount of diverted flow. Access the *Component Editor* by clicking the diversion element icon on the "Components" tab of the *Watershed Explorer* (Figure 187).

## Connecting Diversion Flow

You may optionally choose to connect the diversion flow to another point in the element network. In this case, the diversion flow can become inflow to a junction or other element. This can be useful for representing water that is diverted at a point location in a watershed, moves through a separate channel network, and rejoins the stream from which it was diverted. Properly configured, it can also be used to represent inter-basin transfers. If you do not connect the diversion flow, then it is removed from the system at the diversion element. In either case, the time-series of diversion flow is shown in the graph and time-series tables for the diversion element. The amount of diversion flow is also shown in the diversion element summary table.

The connection for diversion flow is specified on the *Component Editor* for the diversion element. Access the *Component Editor* by clicking the diversion element icon on the "Components" tab of the *Watershed Explorer* (Figure 187). You can also access the *Component Editor* by clicking on the element icon in the basin map, if the map is currently open. The selection list includes all elements that are computationally downstream of the diversion element. Select an element from the list to connect the diversion flow to that element as an inflow, or choose Not Connected.

Figure 187. Diversion component editor. Connecting the diverted flow is optional, as is the maximum volume and maximum diversion flow.

## Limiting Flow or Volume

Two options are available for limiting the amount of water removed from the channel as diversion flow. If neither option is used, the diversion flow will not be limited. If one or both options are used, diversion flow will be computed first without any limitations then reduced as necessary to meet the optional requirements. The optional limitations are included on the *Component Editor* for the diversion

element. Access the *Component Editor* by clicking the diversion element icon on the "Components" tab of the *Watershed Explorer* (Figure 187). You can also access the *Component Editor* by clicking on the element icon in the basin map, if the map is currently open.

The first option for limiting diversion flow is the specification of a maximum volume. Diversion flow is computed normally and the cumulative volume of diverted flow is tracked. Once the cumulative volume reaches the specified maximum volume, all future diversion flow will be set to zero.

The second option for limiting diversion flow is the specification of a maximum allowed flowrate. Diversion flow is initially computed without limitation. For every time interval, the computed diversion flow is compared to the specified maximum flow. If the computed flow is above the maximum flow, the diversion flow is reduced to the specified maximum flow.

### **Selecting a Divert Method**

While a diversion element conceptually represents a diversion from the stream or river, the actual calculations are performed by a divert method contained within the diversion element. Six methods are currently available for computing the diversion flow. The divert method is selected on the *Component Editor* for the diversion element. Access the *Component Editor* by clicking the diversion element icon on the "Components" tab of the *Watershed Explorer* (Figure 187). You can also access the *Component Editor* by clicking on the element icon in the basin map, if the map is currently open. You can select a divert method from the list of six available choices. If you choose the `None` method, the diversion will pass all flow down the main connection and no flow will be diverted. Use the selection list to choose the method you wish to use. Each diversion element may use a different method or several diversions may use the same method.

The parameters for the divert method are presented on a separate *Component Editor* from the diversion element editor. The "Divert" editor is always shown next to the "Diversion" editor. The information shown on the divert editor will depend on which method is currently selected.

### **Constant Flow Divert**

This method uses a constant diversion flowrate for the entire simulation. It is best suited to event simulation when the diversion flow is more likely to be constant. In cases where the diversion flowrate changes during the year according to a reliable pattern, the optional

percentage pattern can be used to adjust the constant rate throughout the year. The *Component Editor* is shown in Figure 188.

The diversion flowrate must be specified. It is entered on the *Component Editor*. If the total inflow to the diversion element is less than the specified diversion flow, the diversion flow will be limited to the total inflow.

Figure 188. Specifying the constant diversion flowrate without using the optional annual adjustment pattern.

An annual adjustment pattern is optional. Without a specified annual pattern, the same diversion flowrate is used for every time interval in the simulation. When a pattern is specified, the diversion value is multiplied by the percentage found in the annual pattern for each time interval in the simulation. The annual pattern provides a percentage that varies throughout the year. The percent annual pattern must be defined in the paired data manager before it can be used in the source element.

### ***Inflow Function Divert***

This method uses a functional relationship between inflow and diversion flow to determine the amount of flow to divert from the channel. The range of inflows specified in the function should cover the complete range of total inflow from upstream elements. Usually the first inflow in the function should be zero. The last inflow should be greater than the maximum anticipated inflow to the element. Diversion flow is the dependent variable and must be specified for each corresponding inflow value. The determination of the correct diversion flow for a specified inflow depends on how the diversion operates. Generally you must compute the diversion for each inflow value using knowledge of the lateral weir, pump station, or other structure that is represented by the diversion element. The *Component Editor* is shown in Figure 189.

Select the inflow-diversion function from the list of available choices. The inflow-diversion function must be specified in the paired data manager before it can be selected in the component editor.

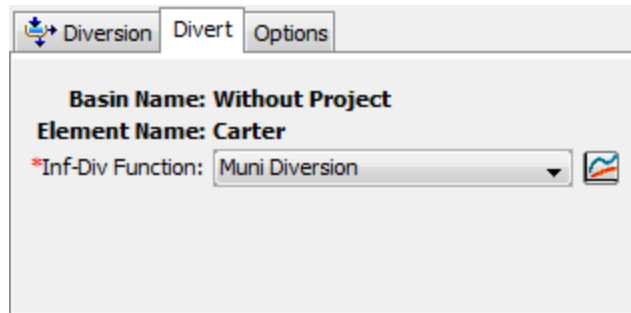

Figure 189. The inflow-diversion function divert editor.

### Lateral Weir Divert

The only method currently available for computing flow over the lateral weir is the broad-crested spillway method. Flow depth in the channel is computed using a rating curve. It is assumed to be level with a uniform head along the length of the weir computed using the rating curve. Tailwater is similarly computed using a rating curve that represents the characteristics of the area where the weir discharges the diverted flow. The *Component Editor* is shown in Figure 190.

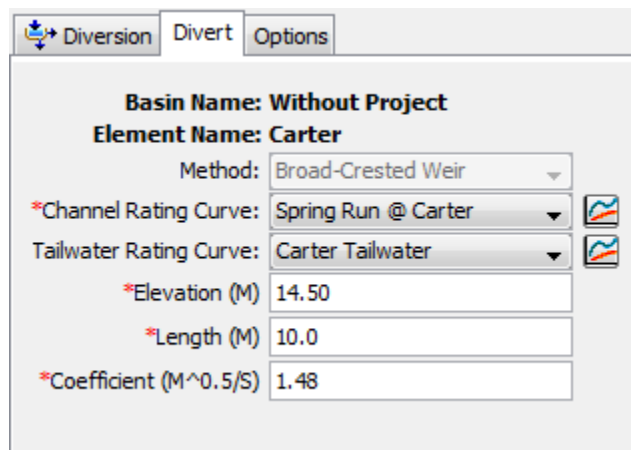

Figure 190. The lateral weir divert method editor.

A rating curve must be selected for the channel. The curve should give the stage for the entire range of inflows that will occur during a simulation. The curve must be monotonically increased. It must be defined in the paired data manager before it can be selected.

Optionally, a rating curve may be entered for tailwater. The curve should give the tailwater stage in the area where the diverted flow is discharged. It is used to automatically account for submergence of the weir. The curve must be monotonically increasing. It must be defined in the paired data manager before it can be selected. If the optional rating curve is not specified, then flow over the weir is computed assuming no tailwater influence.

The crest elevation of the weir must be specified. This should be measured in the same vertical datum as the paired data functions defining the rating curves.

The length of the weir must be specified. This should be the total width through which water passes.

The discharge coefficient accounts for energy losses as water enters the weir, flows over the weir, and then exits. Depending on the exact shape of the weir, typical values range from 1.10 to 1.66 in System International units (2.0 to 3.0 US Customary units).

### **Pump Station Divert**

The pump station divert method is designed to represent one or more pump units extracting water from a channel and discharging it into a canal or other open channel. Flow depth in the channel is computed using a rating curve, then compared with the operating elevations for the pump. Tailwater is similarly computed using a rating curve that represents the characteristics of the area where the pump discharges the diverted flow. The *Component Editor* is shown in Figure 191.

The screenshot shows the 'Pump Station Divert' method editor. It features a tabbed interface with 'Diversion', 'Divert', and 'Options' tabs. The 'Divert' tab is selected. The editor displays the following configuration:

- Basin Name:** Without Project
- Element Name:** Carter
- Method:** Head-Discharge Pump
- \*Channel Rating Curve:** Spring Run @ Carter
- Tailwater Rating Curve:** Carter Tailwater
- Number Units:** 3
- \*Intake Elevation (M):** 10.25
- \*Line Elevation (M):** 15.7
- \*On Elevation (M):** 12.8
- \*Off Elevation (M):** 11.8
- Minimum Rest (MIN):** (empty)
- Minimum Run (MIN):** (empty)
- \*Equipment Loss (M):** 0.042
- \*Head-Discharge Curve:** Model 115

Figure 191. The pump station divert method editor.

A rating curve must be selected for the channel. The curve should give the stage for the entire range of inflows that will occur during a simulation. The curve must be monotonically increased. It must be defined in the paired data manager before it can be selected. You can press the paired data button next to the selection list to use a chooser.

The chooser shows all of the available elevation-discharge functions in the project. Click on a function to view its description.

Optionally, a rating curve may be entered for tailwater. The curve should give the tailwater stage in the area where the diverted flow is discharged. It is used to automatically account for submergence of the pump discharge line. The curve must be monotonically increasing. It must be defined in the paired data manager before it can be selected. If the optional rating curve is not specified, then discharge from the pump is computed assuming no tailwater influence on the discharge line.

The number of identical units must be specified. This allows data to be entered only once when there are multiple pump units with exactly the same parameters.

The intake elevation defines the elevation in the reservoir pool where the pump takes in water. This should be measured in the same vertical datum as the paired data functions defining the storage characteristics of the reservoir.

The line elevation defines the highest elevation in the pressure line from the pump to the discharge point. This should be measured in the same vertical datum as the paired data functions defining the storage characteristics of the reservoir.

You must specify the elevation when the pump turns on. This should be measured in the same vertical datum as the paired data function defining the stage in the channel. Once the pump turns on, it will remain on until the stage in the channel drops below the trigger elevation to turn the pump off.

You must specify the elevation when the pump turns off. This should be measured in the same vertical datum as the paired data function defining the stage in the channel. This elevation must be lower than the elevation at which the pump turns on.

The specification of a minimum rest time is optional. If it is used, once a pump shuts off it must remain off the specified minimum rest time even if the reservoir pool elevation reaches the trigger elevation to turn the pump on.

The specification of a minimum run time is optional. If it is used, once a pump turns on it must remain on the specified minimum run time even if the reservoir pool elevation drops below the trigger elevation to turn the pump off. The only exception is if the pool elevation drops below the intake elevation, then the pump will shut off even though the minimum run time is not satisfied.



The equipment loss includes all energy losses between the intake and discharge points. These losses are sometimes called static losses because they do not change very much even as the water surface elevation in the channel fluctuates. Components of the loss include entrance losses to the suction line, losses in the pump itself, pipe friction losses, bend losses in the line, and exit losses at the end of the discharge line. This loss is added to the dynamic head to determine the total head against which the pump must operate.

The head-discharge curve describes the pumping capability of the pump as a function of the total head. The total head is the sum of the equipment loss and the dynamic head. The dynamic head is first estimated as the difference between the water surface elevation in the channel and the line elevation. If the water surface elevation is above the line elevation, then the estimated value will be zero. Secondly, the estimate is adjusted for tailwater submergence. This second stage is only necessary if an optional tailwater rating curve is specified. When specified, the tailwater water surface elevation is compared to the line elevation. If the tailwater exceeds the line elevation, then the depth of submergence over the line elevation is added to the initial estimate of the dynamic head. The head-discharge curve is used to calculate the diverted flow given the calculated total head. A curve must be defined as an elevation-discharge function in the paired data manager before it can be selected for a pump in the diversion element. You can press the paired data button next to the selection list to use a chooser. The chooser shows all of the available elevation-discharge functions in the project. Click on a function to view its description.

### ***Specified Flow Divert***

The specified flow diversion method is designed for situations where the flow diverted from the channel is measured with a flow gage. Alternately, it can be used if the diversion flow is calculated externally from the program. In either case, the user may enter a time-series of discharges to be diverted from the channel. If the specified diversion discharge exceeds the total inflow to the diversion, then diversion will be limited to the inflow volume. The *Component Editor* is shown in Figure 192.

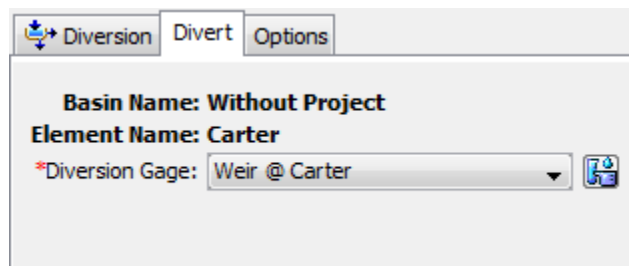

Figure 192. The specified flow divert method.

The time-series discharge gage representing the diversion flows must be defined in the time-series manager before it can be used in the diversion element, as shown in Figure 192. Selecting the correct gage is performed on the *Component Editor* for the diversion element. Access the *Component Editor* by clicking the diversion element icon on the "Components" tab of the *Watershed Explorer*. You can also access the *Component Editor* by clicking on the element icon in the basin map, if the map is currently open.

## Sink

A sink is an element with one or more inflows but no outflow. Multiple inflows are added together to determine the total amount of water entering the element. Sinks can be used to represent the lowest point of an interior drainage area or the outlet of the basin model.

The sink element does not have any special data or properties; it only has the standard *Component Editor* used by all elements. Access the *Component Editor* by clicking the sink element icon on the "Components" tab of the *Watershed Explorer* (Figure 193). You can also access the *Component Editor* by clicking on the element icon in the basin map, if the map is currently open.

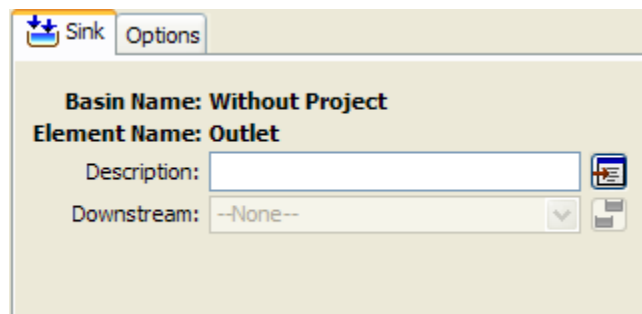

Figure 193. Sink component editor.

## CHAPTER 11

# ***Meteorology Description***

This chapter describes how meteorology information is entered into the program using a meteorologic model. The meteorologic model is responsible for preparing the boundary conditions that act on the watershed during a simulation. Consequently, a meteorologic model is prepared for use with one or more basin models. If the basin model contains subbasin elements, then the meteorologic model must specify how precipitation will be generated for each subbasin. Snowmelt may optionally be included if environmental conditions require it. Evapotranspiration should be included if the basin model is configured for continuous simulation using any of the following loss methods: deficit constant, gridded deficit constant, soil moisture accounting, gridded soil moisture accounting. Finally, when you select energy balance methods for snowmelt or evapotranspiration it will also be necessary to select shortwave and longwave radiation methods.

### ***Meteorologic Models***

Meteorologic models are one of the main components in a project. The principle purpose is to prepare meteorologic boundary conditions for subbasins. Consequently, you must create at least one basin model before creating a meteorologic model. A meteorologic model can be used with many different basin models. However, results computed by the meteorologic model will be matched with the subbasins in the basin models using the name of the subbasin. If subbasins in different basin models have the same name, they will both receive the same boundary conditions from the meteorologic model. Careful naming of subbasins is necessary so that the the correct boundary conditions are computed for each one.

#### ***Creating a New Meteorologic Model***

A new meteorologic model is created using the *Meteorologic Model Manager*. To access the manager, click on the **Components** menu and select the **Meteorologic Model Manager** command. The manager will open and show all of the meteorologic models currently in the project. The manager can remain open while you manage meteorologic models or while you perform tasks elsewhere in the program. You can close the manager using the **X** button in the upper right corner. The buttons to the right of the model list can be used to manage existing models or create a new one. To create a new

meteorologic model, press the **New...** button. After you press the button a window (Figure 194) will open where you can name and describe the new meteorologic model that will be created. A default name is provided for the new model; you can use the default or replace it with your own choice. A description can also be entered. If the description is long, you can press the button to the right of the description field to open an editor. The editor makes it easier to enter and edit long descriptions. When you are satisfied with the name and description, press the **Create** button to finish the process of creating the new meteorologic model. You cannot press the **Create** button if no name is specified for the new model. If you change your mind and do not want to create a new meteorologic model, press the **Cancel** button or the **X** button in the upper right to return to the *Meteorologic Model Manager* window.

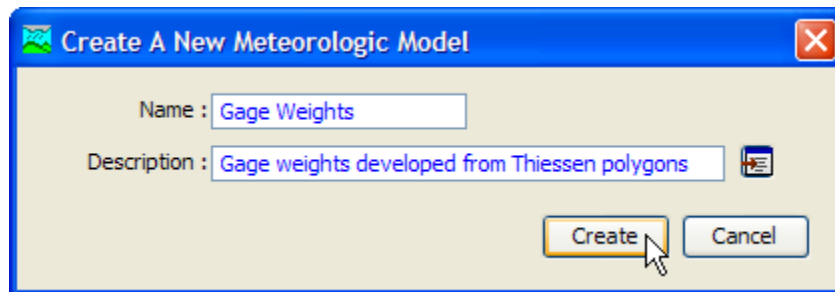

Figure 194. Creating a new meteorologic model. This was accessed by opening the *Meteorologic Model Manager* from the **Components** menu, and then pressing the **New...** button.

### Copying a Meteorologic Model

There are two ways to copy a meteorologic model. Both methods for copying a model create an exact duplicate with a different name. Once the copy has been made it is independent of the original and they do not interact.

The first way to create a copy is to use the *Meteorologic Model Manager*, which is accessed from the **Components** menu. Select the meteorologic model you wish to copy by clicking on it in the list of current meteorologic models. The selected model is highlighted after you select it. After you select a model you can press the **Copy...** button on the right side of the window. A new *Copy Meteorologic Model* window (Figure 195) will open where you can name and describe the copy that will be created. A default name is provided for the copy; you can use the default or replace it with your own choice. A description can also be entered; if it is long you can use the button to the right of the description field to open an editor. When you are satisfied with the name and description, press the **Copy** button to finish the process of copying the selected meteorologic model. You cannot press the **Copy** button if no name is specified. If you change your

mind and do not want to copy the selected meteorologic model, press the **Cancel** button or the **X** button in the upper right to return to the *Meteorologic Model Manager* window.

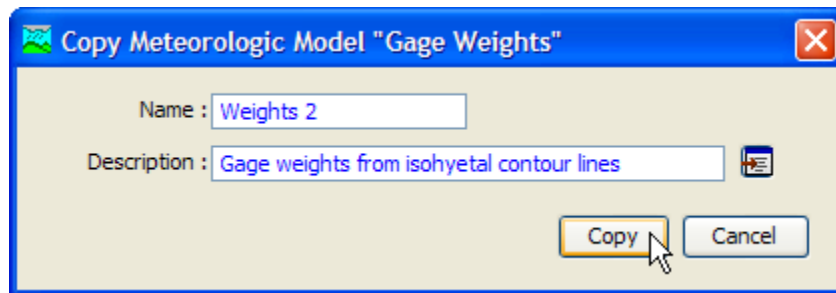

Figure 195. Creating a copy of a meteorologic model.

The second way to copy is from the "Components" tab of the *Watershed Explorer*. Move the mouse over the meteorologic model you wish to copy, then press the right mouse button (Figure 196). A context menu is displayed that contains several choices including copy. Click the **Create Copy...** command. A new *Copy Meteorologic Model* window will open where you can name and describe the copy that will be created. A default name is provided for the copy; you can use the default or replace it with your own choice. A description can also be entered; if it is long you can use the button to the right of the description field to open an editor. When you are satisfied with the name and description, press the **Copy** button to finish the process of copying the selected meteorologic model. You cannot press the **Copy** button if no name is specified. If you change your mind and do not want to copy the selected meteorologic model, press the **Cancel** button or the **X** button in the upper right of the *Copy Meteorologic Model* window to return to the *Watershed Explorer*.

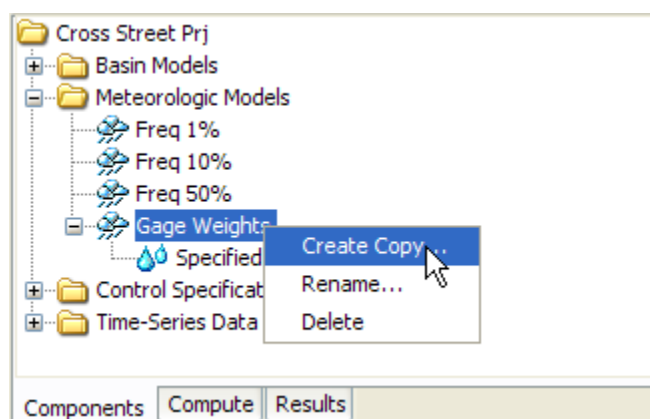

Figure 196. Copying a meteorologic model from the *Watershed Explorer*. The *Copy Meteorologic Model* window will appear after the **Create Copy...** menu command is selected.

## Renaming a Meteorologic Model

There are two ways to rename a meteorologic model. Both methods for renaming a model change its name and then all references to the old model name are automatically updated to the new name.

The first way to perform a rename is to use the *Meteorologic Model Manager*, which you can access from the **Components** menu. Select the meteorologic model you wish to rename by clicking on it in the list of current meteorologic models. The selected model is highlighted after you select it. After you select a model you can press the **Rename...** button on the right side of the window. A new *Rename Meteorologic Model* window (Figure 197) will open where you can provide the new name. If you wish you can also change the description at the same time. If the new description will be long, you can use the button to the right of the description field to open an editor. When you are satisfied with the name and description, press the **Rename** button to finish the process of renaming the selected meteorologic model. You cannot press the **Rename** button if no name is specified. If you change your mind and do not want to rename the selected meteorologic model, press the **Cancel** button or the **X** button in the upper right of the *Rename Meteorologic Model* window to return to the *Meteorologic Model Manager* window.

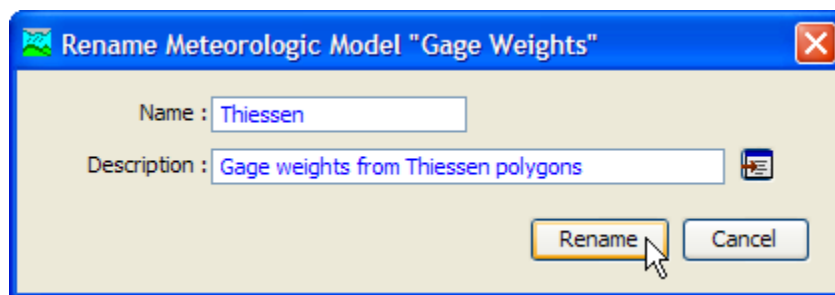

Figure 197. Renaming a meteorologic model. This was accessed from the *Meteorologic Model Manager*.

The second way to rename is from the "Components" tab of the *Watershed Explorer*. Select the meteorologic model you wish to rename by clicking on it in the *Watershed Explorer*; it will become highlighted. Keep the mouse over the selected model and click the right mouse button. Select the **Rename...** command from the menu and the highlighted name will change to editing mode as shown in Figure 198. You can then move the cursor with the arrow keys on the keyboard or by clicking with the mouse. You can also use the mouse to select some or all of the name. Change the name by typing with the keyboard. When you have finished changing the name, press the **Enter** key to finalize your choice. You can also finalize your choice by clicking elsewhere on the "Components" tab. If you change your mind

while in editing mode and do not want to rename the selected meteorologic model, press the **Escape** key.

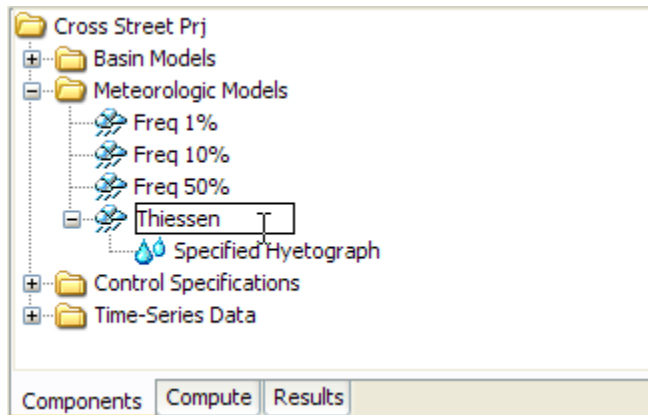

Figure 198. Renaming a meteorologic model in the Watershed Explorer.

### **Deleting a Meteorologic Model**

There are two ways to delete a meteorologic model. Both methods for deleting a model remove it from the project and then automatically update all references to that model. Once a model has been deleted it cannot be retrieved or undeleted. Any references to the deleted model will switch to using no meteorologic model, which is usually not a valid choice during a simulation. At a later time you will have to go to those components and manually select a different meteorologic model.

The first way to perform a deletion is to use the *Meteorologic Model Manager*, which you can access from the **Components** menu. Select the meteorologic model you wish to delete by clicking on it in the list of current meteorologic models. The selected model is highlighted after you select it. After you select a model you can press the **Delete** button on the right side of the window (Figure 199). A window will open where you must confirm that you wish to delete the selected model. Press the **OK** button to delete the model. If you change your mind and do not want to delete the selected meteorologic model, press the **Cancel** button or the **X** button in the upper right to return to the *Meteorologic Model Manager* window.

The second way to delete a meteorologic model is from the "Components" tab of the *Watershed Explorer*. Select the meteorologic model you wish to delete by clicking on it in the *Watershed Explorer*; it will become highlighted. Keep the mouse over the selected model and click the right mouse button (Figure 200). A context menu is displayed that contains several choices including delete. Click the **Delete** command. A window will open where you must confirm that you wish to delete the selected model. Press the **OK** button to delete the model. If you change your mind and do not want to delete the selected

meteorologic model, press the **Cancel** button or the **X** button in the upper right to return to the *Watershed Explorer*.

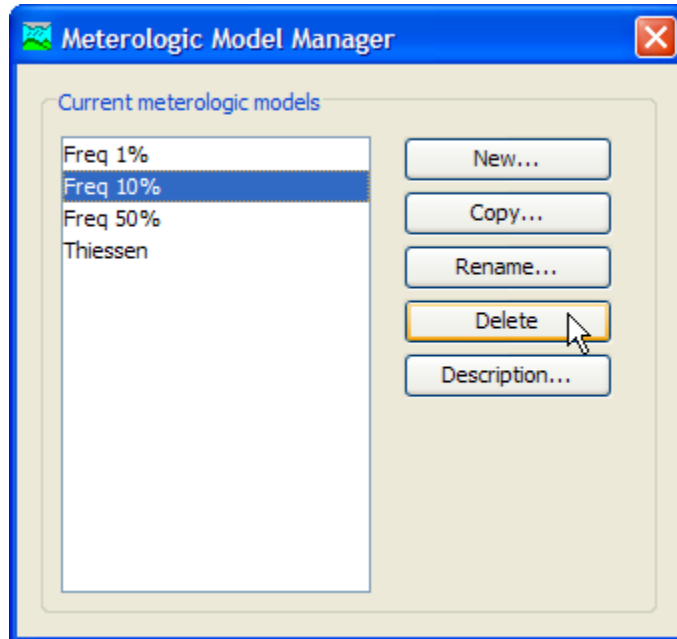

Figure 199. Preparing to delete a meteorologic model from the Meteorologic Model Manager. A confirmation will be required after pressing the **Delete** button.

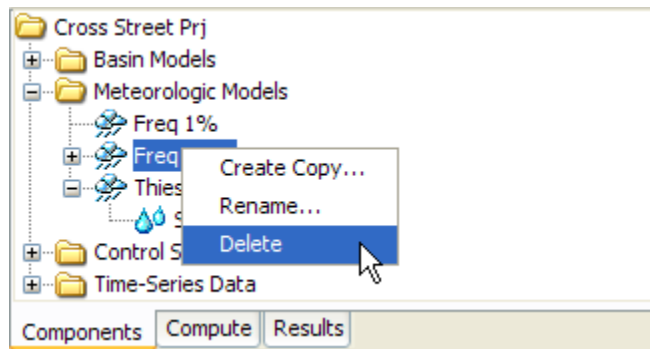

Figure 200. Deleting a meteorologic model in the Watershed Explorer.

### Importing a Meteorologic Model

You can import a meteorologic model from another project into the current project. The model must have been created previously and stored on your computer or an accessible network location. Click the **File** menu and select the **Import** ⇒ **Meteorologic Model** command. A file browser will open that you can use to find the model you wish to import. The browser will only allow you to select meteorologic model files which end with the MET extension. When you click on a meteorologic model file in the browser, the description of the model is shown on the right side of the browser. Once you have located and



selected the desired meteorologic model, press the **Select** button. If you change your mind, you can press the **Cancel** button or the **X** button in the upper right to return to the main program window without importing a model. After you make your selection, the meteorologic model will be checked for dependent data such as time-series gages or parameter grids. The user is given the opportunity to also import any required data. The program automatically copies the selected file and any additional data into the project folder and adds the various components to the project.

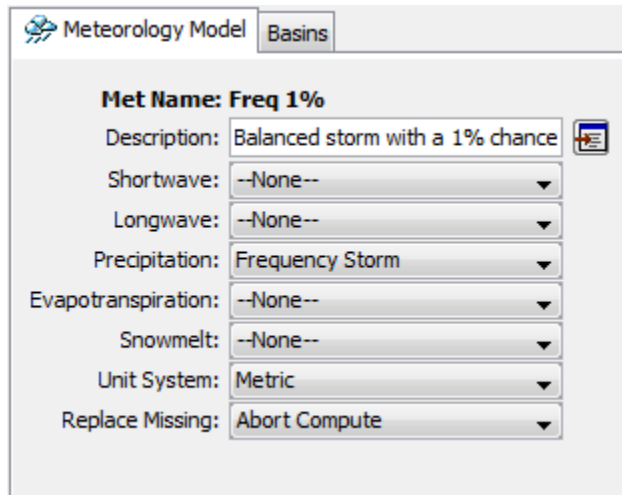

Figure 201. Meteorologic model component editor for selecting the radiation, precipitation, evapotranspiration, and snowmelt methods.

### Shortwave Radiation Method

Shortwave radiation represents the incoming radiation from the sun. It is usually the largest source of energy to the land surface, and is reduced by clouds in the atmosphere. Shortwave radiation is zero at night. There are five different shortwave radiation methods, including the option for no shortwave radiation. Shortwave radiation is only necessary when using energy balance evapotranspiration and snowmelt methods. This includes the Penman Monteith and Priestley Taylor evapotranspiration methods and the energy balance snowmelt method. You can use the "no shortwave" method if you are not using any of these methods.

Select the shortwave radiation method in the *Component Editor* for the meteorologic model (Figure 201). Only one shortwave method can be selected at a time. You can always change the shortwave method. When you change the shortwave method, all data for the old method is deleted and cannot be retrieved or undeleted.

Some shortwave radiation methods require parameter data for each subbasin. Other methods use the same data for all subbasins.

Depending on the method you choose, the *Watershed Explorer* will be updated to indicate which data is required.

### **Longwave Radiation Method**

Longwave radiation represents the radiant energy given off by all bodies. It includes energy radiated by the land surface toward the atmosphere, and also energy radiated by clouds and the empty sky toward the land surface. Net longwave radiation can be either from the atmosphere toward the land surface, or the land surface toward the atmosphere. The direction of net longwave radiation depends on current conditions and temperatures. There are five different longwave radiation methods, including the option for no longwave radiation. Longwave radiation is only necessary when using energy balance evapotranspiration and snowmelt methods. This includes the Penman Monteith evapotranspiration method and the energy balance snowmelt method. You can use the "no longwave" method if you are not using either of these methods.

Select the longwave radiation method in the *Component Editor* for the meteorologic model (Figure 201). Only one longwave method can be selected at a time. You can always change the longwave method. When you change the longwave method, all data for the old method is deleted and cannot be retrieved or undeleted.

Some longwave radiation methods require parameter data for each subbasin. Other methods use the same data for all subbasins. Depending on the method you choose, the *Watershed Explorer* will be updated to indicate which data is required.

### **Precipitation Method**

Precipitation includes all rain and snowfall over the land surface. The determination of liquid or frozen precipitation is performed in the snowmelt method; the precipitation method only determines the amount of water falling to the land surface. There are nine different precipitation methods including an option for no precipitation. If you plan to use the meteorologic model with basin models that contain subbasins, you must choose a precipitation method. If any of the subbasins use the ModClark gridded transform method you must use the gridded precipitation method. You can use the "no precipitation" option if the basin models do not contain subbasins.

Select the precipitation method in the *Component Editor* for the meteorologic model (Figure 201). Only one precipitation method can be selected at a time. You can always change the precipitation method. When you change the precipitation method, all data for the old method is deleted and cannot be retrieved or undeleted.

Some precipitation methods require parameter data for each subbasin. Other methods use the same data for all subbasins. Depending on the method you choose, the *Watershed Explorer* will be updated to indicate which data is required. Also, some precipitation methods have optional settings. If the method you select has optional settings then an additional tab may be added to the *Component Editor*.

### ***Evapotranspiration Method***

The meteorologic model is responsible for computing the potential evapotranspiration over the land surface. The potential evapotranspiration is the amount of evapotranspiration that would occur if there was an infinite supply of water in the soil. The potential amount can generally be computed based on atmospheric conditions. Including evapotranspiration is usually not important for short events, but becomes critical for longer simulations. There are seven different evapotranspiration methods including an option for no evapotranspiration. If you plan to use the meteorologic model with basin models that contain subbasins, you may need to choose an evapotranspiration method. The following loss methods require evapotranspiration boundary conditions: deficit constant, gridded deficit constant, soil moisture accounting, gridded soil moisture accounting. If you use a meteorologic model with subbasins using any of those loss methods, you should select an evapotranspiration method. If you use those loss methods but no evapotranspiration method is selected in the meteorologic model, then evapotranspiration is assumed to be zero in the subbasins. A gridded evapotranspiration method is provided for use with the ModClark gridded transform method. Using a gridded evapotranspiration method provides separate boundary conditions for each grid cell. Using a non-gridded evapotranspiration method means that the same boundary condition will be applied at each grid cell in a subbasin.

Select the evapotranspiration method in the *Component Editor* for the meteorologic model (Figure 201). Only one evapotranspiration method can be selected at a time. You can always change the evapotranspiration method. When you change the evapotranspiration method, all data for the old method is deleted and cannot be retrieved or undeleted.

Some evapotranspiration methods require parameter data for each subbasin. Other methods use the same data for all subbasins. Depending on the method you choose, the *Watershed Explorer* will be updated to indicate which data is required.

## **Snowmelt Method**

The snowmelt method determines if precipitation is rain or snow using air temperature. The precipitation method is responsible for estimating the total depth of combined rain and snow. Once the amount of precipitation is determined by the precipitation method, the state of the precipitation is determined by the snowmelt method. Subsequently, the snowmelt method tracks the accumulation and melting of the snowpack throughout the winter season. The snowmelt methods can also operate during the summer season when precipitation is generally purely rain and no snowpack accumulates. There are five different snowmelt methods including an option for no snowmelt. Snowmelt is only required if you plan to use the meteorologic model with basin models that contain subbasins and the watershed receives precipitation as snow, or as both rain and snow. If any of the subbasins use the ModClark gridded transform method you must use a gridded snowmelt method.

Select the snowmelt method in the *Component Editor* for the meteorologic model (Figure 201). Only one snowmelt method can be selected at a time. You can always change the snowmelt method. When you change the snowmelt method, all data for the old method is deleted and cannot be retrieved or undeleted.

Some snowmelt methods require parameter data for each subbasin, and for elevation bands within each subbasin. Other methods use the same data for all subbasins. Depending on the method you choose, the *Watershed Explorer* will be updated to indicate which data is required.

## **Unit System**

Each meteorologic model must be in either United States customary units (sometimes called English units) or in system international units (also called metric units). All parameter data in a meteorologic model, whether for all subbasins or individual subbasins, must be in the same unit system. If you change the unit system, all data will be automatically converted to the new unit system. All time-series data, paired data, and gridded data referenced in a meteorologic model will be in its own unit system. If necessary, these referenced data are automatically converted to the unit system of the meteorologic model during a simulation.

Select the unit system using the *Component Editor* for the meteorologic model (Figure 201). Access the *Component Editor* by clicking on the meteorologic model icon on the "Components" tab of the *Watershed Explorer*. If you change the unit system, all data is automatically converted to the new selection.

## **Missing Data**

Missing data is a common problem with atmospheric measurements. The exact meaning of missing data often depends on the type of data. Missing precipitation data often means that no precipitation was occurring. Care must be used, but it is often possible to assume that zero rainfall can be substituted for missing data. Other types of atmospheric measurements are more difficult to manage when data is missing. When air temperature is missing there is usually no reasonable substitution that can be made.

There are two options for managing missing data in the meteorologic model. The first option is to abort the compute with an error message. Using this option means that when any missing data is encountered, the simulation is stopped and an error message will report the time-series gage or grid that contained the missing data. Using this approach is the best because it requires all atmospheric data to be reviewed and corrected before use in a simulation. The second option is to assume a default value. For example, with this option selected any missing precipitation data will be assumed to be zero. However, allowing missing data to be replaced with a default value sometimes leads to inconsistent results that can be difficult to interpret. Furthermore, some types of data such as temperature have no default value. The compute will always abort with an error message when missing data is encountered for data types with no defined default value.

Select the action to take for missing data using the *Component Editor* for the meteorologic model (Figure 201). Access the *Component Editor* by clicking on the meteorologic model icon on the "Components" tab of the *Watershed Explorer*.

## **Selecting Basin Models**

The main purpose of a meteorologic model is to prepare meteorologic boundary conditions for subbasins. These boundary conditions include precipitation and when also necessary, shortwave radiation, longwave radiation, potential evapotranspiration, and snowmelt. The meteorologic model must be configured to compute the necessary boundary conditions. This is accomplished by specifying which basin models will be used with each meteorologic model as shown in Figure 202. Once a basin model is selected to work with a meteorologic model, the subbasins are connected to the meteorologic model. The connection is performed using the name of the subbasin. If several basin models all include a subbasin with the same name, the meteorologic model will compute the same boundary conditions for the subbasin in each model. If you want each subbasin to have unique boundary conditions, then the name of the subbasin must be unique

across all basin models that will be used with the same meteorologic model.

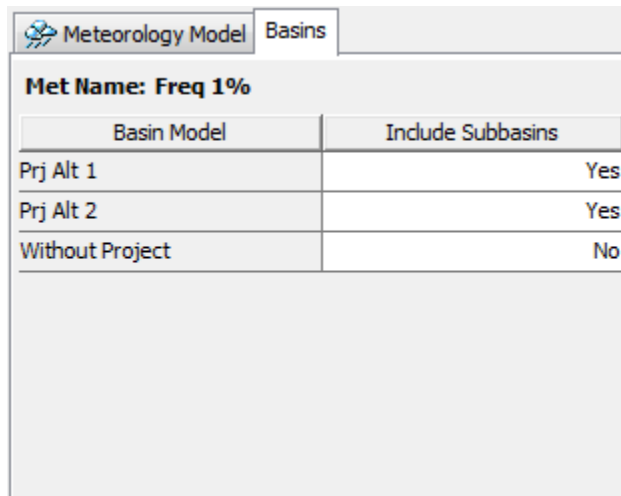

Met Name: Freq 1%	
Basin Model	Include Subbasins
Prj Alt 1	Yes
Prj Alt 2	Yes
Without Project	No

*Figure 202. Specifying which basin models should be used with a meteorologic model. The meteorologic model will be setup to work with all of the subbasins in the selected basin models.*

Once a basin model is selected to work with a meteorologic model, the meteorologic model is automatically kept synchronized with changes in that basin model. When a basin model is renamed it is updated in all meteorologic models working with that basin model. When a basin model is deleted, any subbasins it contains are removed from all meteorologic models working with that basin model. However, subbasins will not be removed from a meteorologic model when a basin model is deleted if the subbasins are also included in other basin models still used by the meteorologic model. Subbasins are likewise removed if a basin model is unselected from a meteorologic model. Similar changes are also made automatically when subbasins are added to or deleted from a basin model set to work with a meteorologic model, or when they are renamed. Subbasins added to a basin model will be automatically added to all meteorologic models set to work with that basin model. Subbasins deleted from a basin model will be removed from all meteorologic models set to work with that basin model, so long as the subbasin is not included in any other basin models connected to a meteorologic model. Finally, renamed subbasins will also be renamed in the meteorologic model. However, if other basin models connected to the meteorologic model contain subbasins with the same name as the old name of the renamed subbasin, they will retain their original name and parameter data while the renamed subbasin receives a copy of the data.

The "Basins" tab, part of the *Component Editor* for the meteorologic model, is used to connect basin models to the meteorologic model. The "Basins" tab shows a table of all current basin models in the

project. Each basin model can be selected or unselected to work with the meteorologic model. The table is automatically updated as basin models are created, renamed, or deleted.

### ***Atmospheric Variables***

Atmospheric variables are measurable properties of the atmosphere that change over time in response to external influences. The measured values provide insight to short term weather phenomena as well as long term climate trends. The measured values are also input to a number of physically-based models used to quantify various components of the hydrologic cycle including evapotranspiration and snowmelt, among others. Meteorologists and climatologists have established standard scientific methods for making measurements of the atmospheric variables.

The most common atmospheric variable is air temperature which measures the internal energy of the air. The average speed of moving air is defined as the windspeed. The air pressure is defined as the absolute pressure which is actually the weight of the atmosphere. The amount of water vapor in the air can be measured either as relative humidity or dew point temperature.

Atmospheric variables are required for each subbasin when certain methods are selected for shortwave radiation, longwave radiation, evapotranspiration, and snowmelt. The same variables may be required for more than one method, for example, a shortwave radiation method and evapotranspiration method may both require the same variable. When necessary, time-series gages must be selected for each subbasin in order to specify the atmospheric variables. Click on the subbasin in the *Watershed Explorer* as shown in Figure 203 to access the *Component Editor* for the atmospheric variables (Figure 204). Gages only need to be selected for atmospheric variables that are required based on selections in the meteorologic model. Variables are enabled when they are required. Variables are disabled when they are not required and no selection can be made.

Observations for the atmospheric variables must be defined in the Time-Series Data Manager before they can be selected in the *Component Editor*. Chapter 5 of this manual describes how to create and manage time-series data. The available gages are shown in the selection list for each variable. If there are many different gages available, you may wish to choose a gage from the selector accessed with the gage button next to the selection list. The selector displays the description for each gage, making it easier to select the correct one.

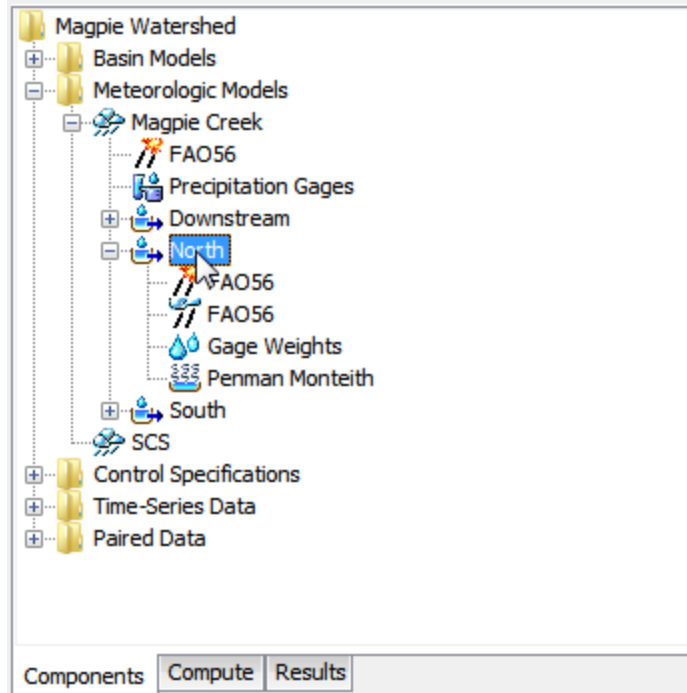

Figure 203. Click on a subbasin node to specify atmospheric variables.

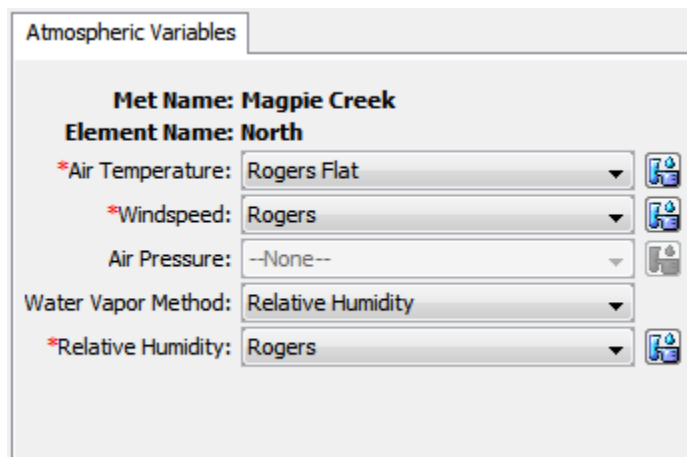

Figure 204. The selected meteorologic model methods require air temperature, windpeed, and water vapor. Air pressure is not required in this case.

## Shortwave Radiation

Shortwave radiation is a radiant energy produced by the sun with wavelengths ranging from infared through visible to ultraviolet. Shortwave radiation is therefore exclusively associated with daylight hours for a particular location on the Earth's surface. The energy arrives at the top of the Earth's atmosphere with a flux (Watts per square meter) that varies very little during the year and between years. Consequently the flux is usually taken as a constant for hydrologic



simulation purposes. Some of the incoming radiation is reflected by the top of the atmosphere and some is reflected by clouds. A portion of the incoming radiation is absorbed by the atmosphere and some is absorbed by clouds. The albedo is the fraction of the shortwave radiation arriving at the land surface that is reflected back into the atmosphere. The shortwave radiation that is not reflected or absorbed above the land surface, and is not reflected by the land surface, is available to drive hydrologic processes such as evapotranspiration and snowpack melting.

The shortwave radiation method included in the meteorologic model is only necessary when energy balance methods are used for evapotranspiration or snowmelt. The options available cover a range of detail from simple to complex. Simple specified methods are also available for input of a time-series gage or grid. Each option produces the net shortwave radiation arriving at the land surface where it may be reflected or absorbed. More detail about each method is provided in the following sections.

### ***Bristow Campbell***

The Bristow Campbell method (Bristow and Campbell, 1984) uses a conceptual approach to estimating the shortwave radiation at the land surface. During the daylight hours, any clouds present in the atmosphere will block some portion of incoming solar radiation which reduces solar heating and results in a lower temperature. Conversely, lack of clouds permits much more of the solar radiation to pass through the atmosphere which allows greater heating and generally higher air temperatures. In theory the daily temperature range should be small on cloudy days and large on non-cloudy days. This correlation between temperature range and incoming solar radiation is exploited as a simple way to compute shortwave radiation using only air temperature.

The Bristow Campbell method includes a *Component Editor* with parameter data for each subbasin in the meteorologic model. The *Watershed Explorer* provides access to the shortwave component editor using a picture of solar radiation (Figure 205).

An air temperature gage must be selected in the atmospheric variables for each subbasin.

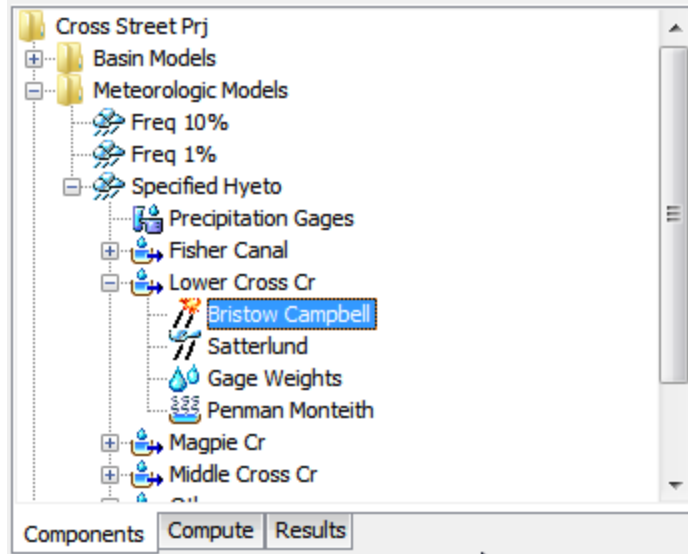

Figure 205. A meteorologic model using the Bristow Campbell shortwave radiation method with a component editor for each individual subbasin.

The *Component Editor* for each subbasin in the meteorologic model is used to enter parameter data (Figure 206). The transmittance represents the maximum clear sky characteristics over the watershed. The default value of the transmittance is 0.70. The exponent controls the timing of the maximum temperature and may vary from humid to arid environments. The default value of the exponent is 2.4.

The average monthly temperature range must be entered. This value is the difference between the average monthly high temperature and the average monthly low temperature.

Bristow Campbell	
<b>Met Name: Specified Hyeto</b>	
<b>Element Name: Lower Cross Cr</b>	
*Transmittance:	0.70
*Exponent:	2.4
*Jan Range (DEG C)	8
*Feb Range (DEG C)	10
*Mar Range (DEG C)	11
*Apr Range (DEG C)	14
*May Range (DEG C)	16
*Jun Range (DEG C)	18
*Jul Range (DEG C)	18
*Aug Range (DEG C)	19
*Sep Range (DEG C)	18
*Oct Range (DEG C)	16
*Nov Range (DEG C)	12
*Dec Range (DEG C)	9

Figure 206. Entering atmosphere and temperature data for a subbasin using the Bristow Campbell shortwave radiation method.

## FAO56

The FAO56 method implements the algorithm detailed by Allen, Pereira, Raes, and Smith (1998). The algorithm calculates the solar declination and solar angle for each time interval of the simulation, using the coordinates of the subbasin, Julian day of the year, and time at the middle of the interval. The solar values are used to compute the extra-terrestrial radiation for each subbasin. Total daylight hours are computed based on the Julian day and compared to the number of actual sunshine hours. Shortwave radiation arriving at the ground surface is then computed using the most common relationship accounting for reduction in sunshine hours due to cloud cover.

The *Watershed Explorer* provides access to the shortwave component editors using a picture of solar radiation (Figure 207). The FAO56 method includes a *Component Editor* with parameter data for all subbasins in the meteorologic model (Figure 208); the same data is also shared with the FAO56 longwave radiation method. A *Component Editor* is also included for each subbasin (Figure 209).

An air temperature gage and a windspeed gage must be selected in the atmospheric variables for each subbasin. Additionally, the water

vapor must be specified with either a relative humidity or dew point temperature gage.

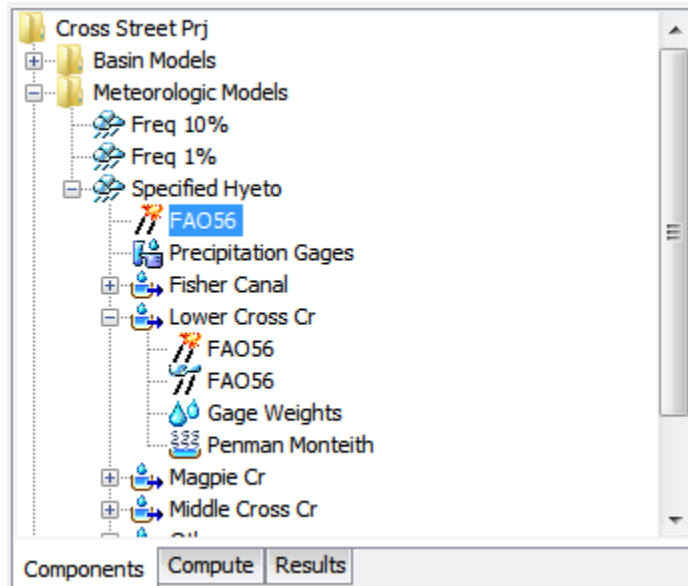

Figure 207. A meteorologic model using the FAO56 shortwave radiation method with a component editor for each individual subbasin.

A *Component Editor* for all subbasins in the meteorologic model includes the central meridian of the time zone (Figure 208). There is currently no specification for the time zone so the meridian must be specified manually. The central meridian is commonly the longitude at the center of the local time zone. Meridians west of zero longitude should be specified as negative while meridians east of zero longitude should be specified as positive. The meridian may be specified in decimal degrees or degrees, minutes, and seconds depending on the program settings.

FAO56	
<b>Met Name: Specified Hyeto</b>	
*Meridian Degrees:	-119
*Meridian Minutes:	22
*Meridian Seconds:	38

Figure 208. Entering the longitude of the central meridian of the local time zone.

The *Component Editor* for each subbasin in the meteorologic model is used to enter parameter data necessary to account for differences in cloud cover across the watershed (Figure 209). Cloud cover is

considered through a time-series of sunshine hours. Sunshine hours are defined as the number of decimal hours per full hour where the shortwave radiation exceeds 120 watts per square meter (WMO, 2008).

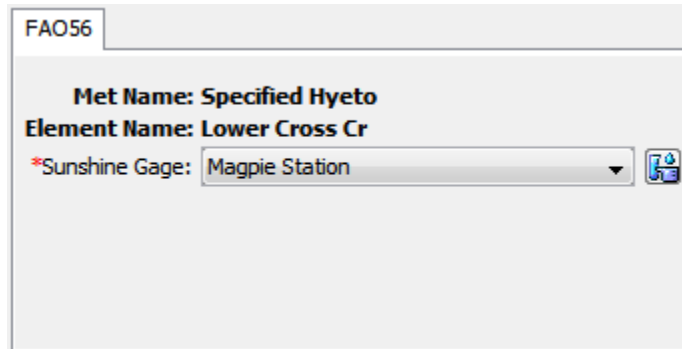

Figure 209. Selecting a time-series gage for the sunshine hours.

### **Gridded Shortwave**

The gridded shortwave method is designed to work with the ModClark gridded transform. However, it can be used with other area-average transform methods as well. The most common use of the method is to utilize gridded shortwave radiation estimates produced by an external model, for example, a dynamic atmospheric model. If it is used with a transform method other than ModClark, an area-weighted average of the grid cells in the subbasin is used to compute the shortwave radiation time-series for each subbasin.

The gridded shortwave method includes a *Component Editor* with parameter data for all subbasins in the meteorologic model. The *Watershed Explorer* provides access to the shortwave component editor using a picture of solar radiation (Figure 210).

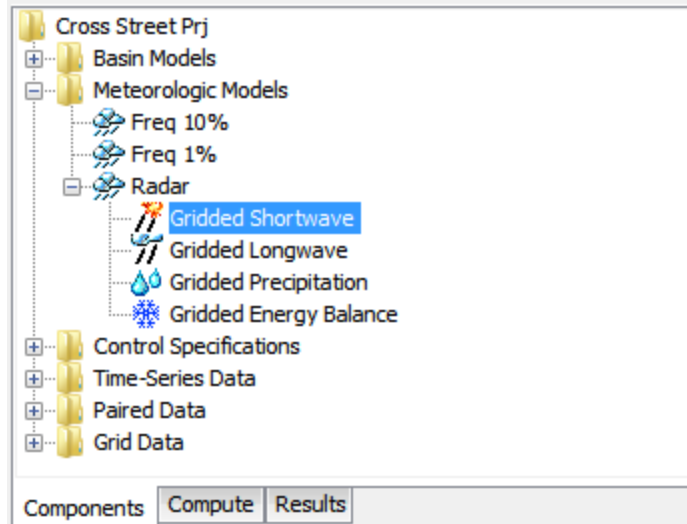

Figure 210. A meteorologic model using the gridded shortwave method with a component editor for all subbasins in the meteorologic model.

A *Component Editor* for all subbasins in the meteorologic model includes the selection of the data source (Figure 211). A radiation gridset must be selected for all subbasins. The current gridsets are shown in the selection list. If there are many different gridsets available, you may wish to choose a gridset from the selector accessed with the grid button next to the selection list. The selector displays the description for each gridset, making it easier to select the correct one.

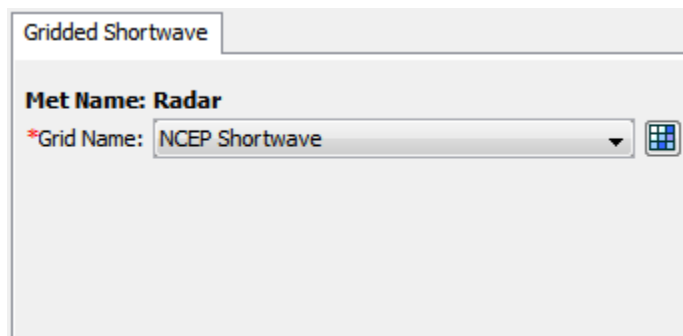

Figure 211. Specifying the shortwave radiation data source for the gridded shortwave method.

### **Specified Pyranograph**

A pyranometer is an instrument that can measure incoming solar shortwave radiation. They are not part of basic meteorological observation stations, but may be included at first order stations. This method may be used to import observed values from a pyranometer or it may be used to import estimates produced by an external model. This is the recommended choice for use with the Priestley Taylor

evapotranspiration method, where an effective radiation is used which includes both shortwave and longwave radiation.

The specified pyranograph method includes a *Component Editor* with parameter data for all subbasins in the meteorologic model. The *Watershed Explorer* provides access to the shortwave component editors using a picture of solar radiation (Figure 212).

The *Component Editor* for all subbasins in the meteorologic model includes the time-series gage of shortwave radiation for each subbasin (Figure 213). A solar radiation gage must be selected for a subbasin. The current gages are shown in the selection list.

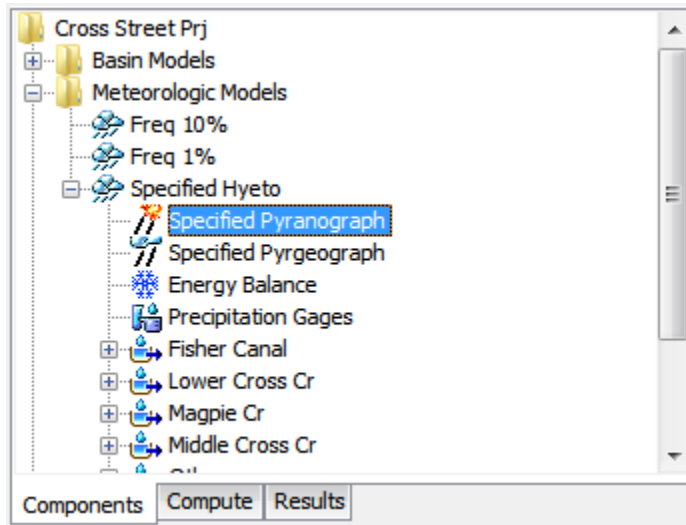

Figure 212. A meteorologic model using the specified pyranograph shortwave method with a component editor for all subbasins.

Specified Pyranograph	
Met Name: Specified Hyeto	
Subbasin Name	Gage
Fisher Canal	MYV Solar
Lower Cross Cr	MYV Solar
Magpie Cr	MYV Solar
Middle Cross Cr	MYV Solar
Other	MYV Solar

Figure 213. Specifying the shortwave radiation time-series gage for each subbasin.

## **Longwave Radiation**

All living and non-living bodies emit longwave radiation. The magnitude of the radiation is proportional to the temperature (measured in Kelvin degrees) of the body raised to the fourth power. Significant sources of longwave radiation in hydrologic applications include the atmosphere itself, and any clouds that may be present locally in the atmosphere. Clouds usually have a higher heat content and higher temperature than clear atmosphere, and therefore there is increased downwelling longwave radiation on cloudy days. Whether the atmosphere and clouds are a net source of longwave radiation to the land surface depends on their temperature relative to the land surface temperature. In most cases, the net longwave radiation is incoming during the daylight hours, and outgoing during the night hours.

The longwave radiation method included in the meteorologic model is only necessary when energy balance methods are used for evapotranspiration or snowmelt. The options available cover a range of detail from simple to complex. Simple specified methods are also available for input of a time-series or grid. Each option produces the downwelling longwave radiation arriving at the land surface. Absorption and radiation by the land surface is computed within the subbasin element. More detail about each method is provided in the following sections.

### **FAO56**

The FAO56 method implements the algorithm detailed by Allen, Pereira, Raes, and Smith (1998). The algorithm calculates the solar declination and solar angle for each time interval of the simulation, using the coordinates of the subbasin, Julian day of the year, and time at the middle of the interval. The solar values are used to compute the clear sky radiation for each subbasin. The computed shortwave radiation is then divided by the calculated clear sky radiation to estimate the fraction of shortwave radiation reaching the ground. Finally, the fraction of shortwave radiation reaching the ground is combined with the vapor pressure to calculate a reduction to the downwelling longwave radiation based on the Stefan-Bolzman equation.

The FAO56 method includes a *Component Editor* with parameter data for all subbasins in the meteorologic model; the same data is also shared with the FAO56 shortwave radiation method. When FAO56 is used for both shortwave and longwave radiation, the icon will preferentially show the shortwave icon. A *Component Editor* is also included for each subbasin. The *Watershed Explorer* provides access



to the longwave component editors using a picture of cloud black body radiation (Figure 214).

An air temperature gage and a windspeed gage must be selected in the atmospheric variables for each subbasin. Additionally, the water vapor must be specified with either a relative humidity or dew point temperature gage.

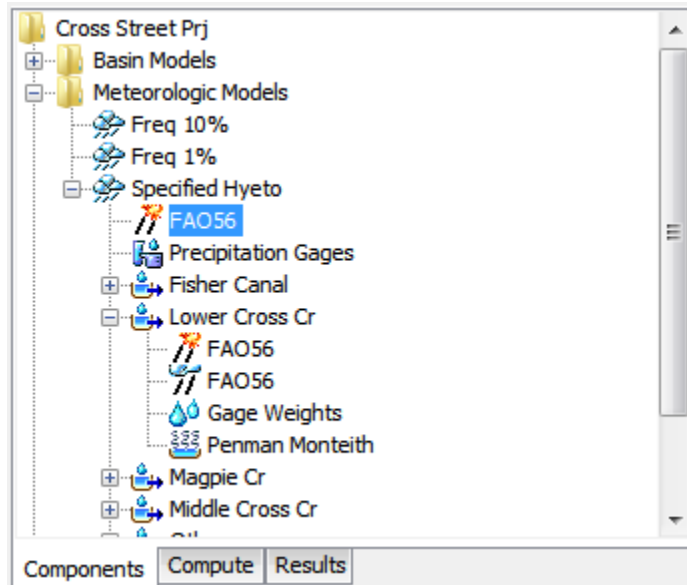

Figure 214. The FAO56 shortwave and FAO56 longwave methods use the same editor for all subbasins.

A *Component Editor* for all subbasins in the meteorologic model includes the central meridian of the time zone (Figure 215). There is currently no specification for the time zone so the meridian must be specified manually. The central meridian is commonly the longitude at the center of the local time zone. Meridians west of zero longitude should be specified as negative while meridians east of zero longitude should be specified as positive. The meridian may be specified in decimal degrees or degrees, minutes, and seconds depending on the program settings.

FAO56

**Met Name: Specified Hyeto**

\*Meridian Degrees: -119

\*Meridian Minutes: 22

\*Meridian Seconds: 38

Figure 215. The FAO56 shortwave and FAO56 longwave methods both require the time zone central meridian.

The *Component Editor* for each subbasin in the meteorologic model is used to enter parameter data necessary to account for differences from the clear sky black body radiation (Figure 117). Currently the only method for calculating the differences from clear sky radiation is based on elevation. A representative elevation should be entered for each subbasin.

FAO56

**Met Name: Specified Hyeto**

**Element Name: Lower Cross Cr**

Clear Sky Method: Elevation

\*Elevation (M) 980

Figure 216. Specifying the representative elevation for the subbasin.

## Gridded Longwave

The gridded longwave method is designed to work with the ModClark gridded transform. However, it can be used with other area-average transform methods as well. The most common use of the method is to utilize gridded longwave radiation estimates produced by an external model, for example, a dynamic atmospheric model. If it is used with a transform method other than ModClark, an area-weighted average of the grid cells in the subbasin is used to compute the longwave radiation time-series for each subbasin.

The gridded longwave method includes a *Component Editor* with parameter data for all subbasins in the meteorologic model. The *Watershed Explorer* provides access to the longwave component editor using a picture of downwelling radiation from clouds (Figure 217).

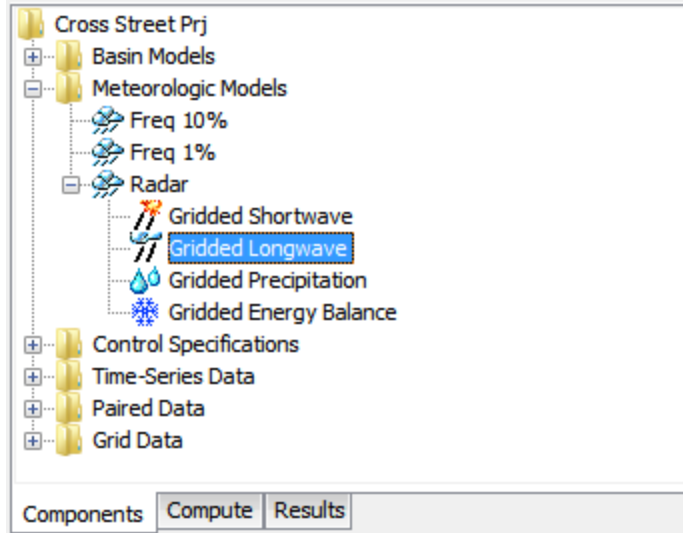

Figure 217. A meteorologic model using the gridded longwave method with a component editor for all subbasins in the meteorologic model.

A *Component Editor* for all subbasins in the meteorologic model includes the selection of the data source (Figure 218). A radiation gridset must be selected for all subbasins. The current gridsets are shown in the selection list. If there are many different gridsets available, you may wish to choose a gridset from the selector accessed with the grid button next to the selection list. The selector displays the description for each gridset, making it easier to select the correct one.

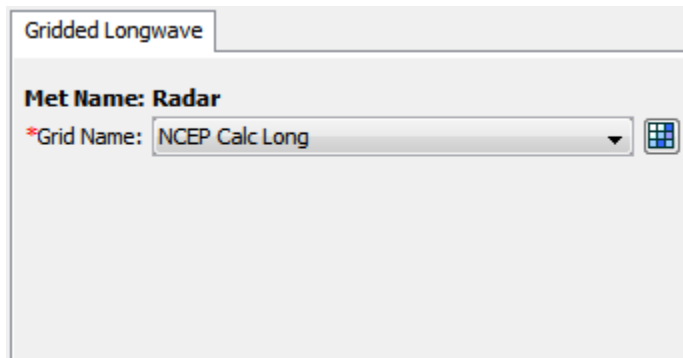

Figure 218. Specifying the longwave radiation data source for the gridded longwave method.

## Satterlund

The Satterlund method (Satterlund, 1979) uses temperature and vapor pressure to estimate incoming longwave radiation. While certain physical limits are enforced, the approach is fundamentally empirical. It provides good estimates under mostly clear skies and continues to perform well even as temperature drops below the freezing point. It

has the advantage of requiring only readily available meteorologic data.

The Satterlund method includes a *Component Editor* with parameter data for each subbasin in the meteorologic model. The *Watershed Explorer* provides access to the longwave component editors using a picture of heat radiation from a cloud (Figure 219).

An air temperature gage and a windspeed gage must be selected in the atmospheric variables for each subbasin. Additionally, the water vapor must be specified with either a relative humidity or dew point temperature gage.

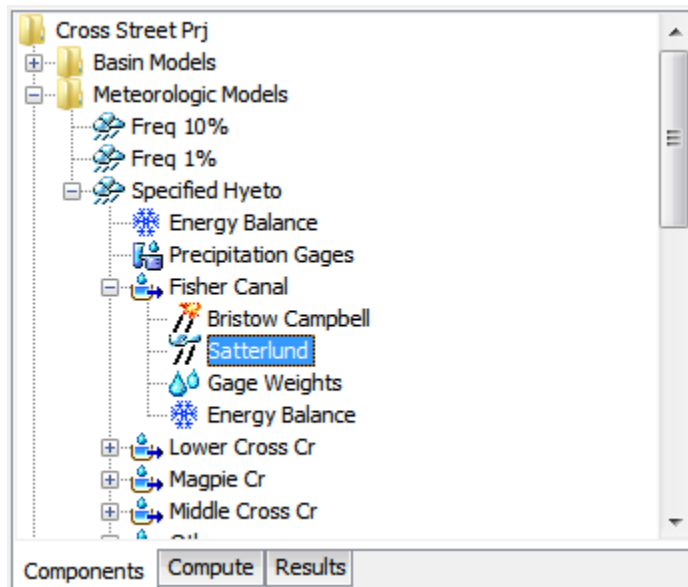

Figure 219. A meteorologic model using the Satterlund longwave method with a component editor for all subbasins in the meteorologic model.

The incoming longwave radiation is computed using a modified form of the equation for ideal black body radiation. The emissivity is calculated as a function of the temperature, where the temperature coefficient has a default value of 2016 Kelvin. An emissivity coefficient is included for calibration, though the default value of 1.08 is widely used. The emissivity and temperature coefficients can be entered in the *Component Editor* as shown in Figure 220.

Satterlund

**Met Name: Specified Hyeto**  
**Element Name: Fisher Canal**

\*Emissivity Coefficient: 1.08

\*Temperature Coefficient: 2016

Figure 220. Specifying the thermodynamic properties for each subbasin.

## Specified Pyrgeograph

A pyrgeometer is an instrument that can measure downwelling longwave radiation. They are not part of basic meteorological observation stations, but may be included at first order stations. This method may be used to import observed values from a pyrgeometer or it may be used to import estimates produced by an external model.

The specified pyrgeograph method includes a *Component Editor* with parameter data for all subbasins in the meteorologic model. The *Watershed Explorer* provides access to the longwave component editors using a picture of heat radiation from a cloud (Figure 221).

The *Component Editor* for all subbasins in the meteorologic model includes the time-series gage of longwave radiation for each subbasin (Figure 222). A radiation gage must be selected for a subbasin. The current gages are shown in the selection list.

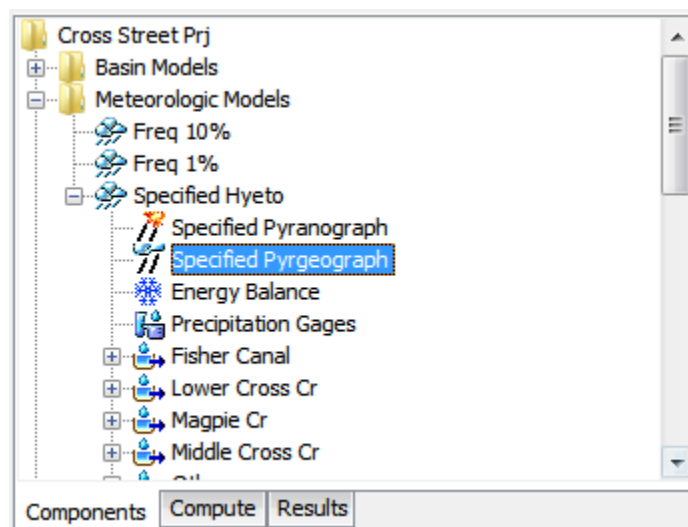

Figure 221. A meteorologic model using the specified pyrgeograph longwave method with a component editor for all subbasins in the meteorologic model.

Specified Pyrgeograph	
Met Name: Specified Hyeto	
Subbasin Name	Gage Name:
Fisher Canal	MYV Calc Long
Lower Cross Cr	MYV Calc Long
Magpie Cr	MYV Calc Long
Middle Cross Cr	MYV Calc Long
Other	MYV Calc Long

Figure 222. Specifying the longwave radiation time-series gage for each subbasin.

## Precipitation

Precipitation is water falling over the land surface. It is caused when water vapor in the atmosphere condenses on airborne nuclei such as dust particles. Condensation continues to add to the droplet forming around the nuclei until the weight of the droplet exceeds the ability of wind currents to keep it aloft. Precipitation can be caused by different types of storms including stratiform, convection, and cyclone which each have typical characteristics of duration, intensity, and spatial extent. Precipitation includes the liquid form known as rain as well as a variety of frozen forms including sleet, snow, graupel, and hail. Most hydrologic purposes can be met by limiting consideration to rain and snow. The determination of the rain or snow state is made separately in the snowmelt portion of the meteorologic model.

The precipitation method included in the meteorologic model is required whenever a basin model includes subbasin elements. The options available include several that process gage measurements, a statistical method that uses depth-duration data, several design storms options, and a gridded method that can be used with radar rainfall data. Each option produces a hyetograph of precipitation falling over each subbasin. More detail about each method is provided in the following sections.

### Frequency Storm

The frequency storm method is designed to produce a synthetic storm from statistical precipitation data. The most common source of statistical data in the United States is the National Weather Service. Typically the data is given in the form of maps, where each map shows the expected precipitation depth for a storm of specific duration and exceedance probability. This method is designed to use data collected

from the maps along with other information to compute a hyetograph for each subbasin.

The frequency storm method includes a *Component Editor* with parameter data for all subbasins in the meteorologic model, and a separate *Component Editor* for each individual subbasin. The *Watershed Explorer* provides access to the precipitation component editors using a picture of raindrops (Figure 223).

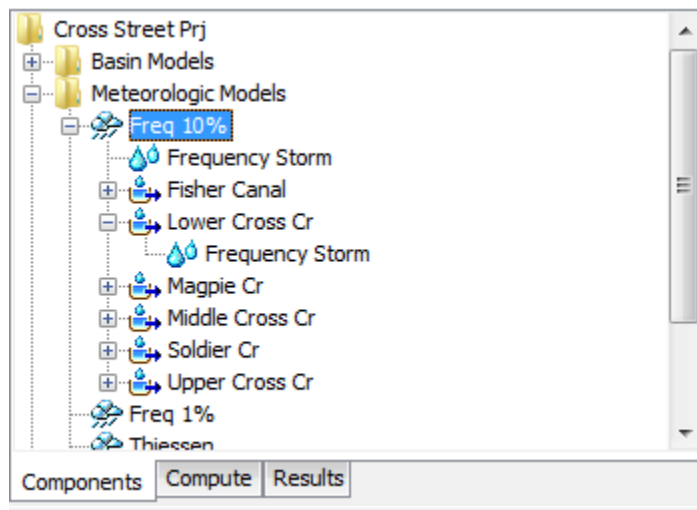

Figure 223. A meteorologic model using the frequency precipitation method with a *Component Editor* for all subbasins, and a separate *Component Editor* for each individual subbasin.

The *Component Editor* for all subbasins in the meteorologic model includes parameter data to describe the frequency storm (Figure 224). Each storm has a single exceedance probability which must be selected from the list of available choices. The choices range from 0.2 to 50 percent and generally match the precipitation maps that are commonly available. Please note that return interval is not used in the program.

The frequency storm method is designed to accept partial or annual-duration precipitation depth-duration data. The type of input data must be selected. The method is also able to provide output in either partial or annual-duration. The difference between partial and annual-duration output is extremely small for exceedance probabilities 4% and smaller; you must select the type when the 10%, 20% or 50% exceedance probability is selected. The default selection is partial duration input and annual duration output.

The intensity duration specifies the shortest time period of the storm. Usually the duration should be set equal to the time step of the simulation. It must be less than the total storm duration. Storm duration determines how long the precipitation will last. It must be

longer than the intensity duration. If the simulation duration is longer than the storm duration, all time periods after the storm duration will have zero precipitation.

Precipitation

**Met Name: Freq 10%**

Probability: 1 Percent

Input Type: Partial Duration

Output Type: Annual Duration

Intensity Duration: 15 Minutes

Storm Duration: 6 Hours

Intensity Position: 50 Percent

Storm Area (KM2): 129.8

Curve: Uniform For All Subbasins

Duration	Partial-Duration Depth (MM)
5 Minutes	
15 Minutes	34.500
1 Hour	66.800
2 Hours	77.700
3 Hours	84.600
6 Hours	100.30

Figure 224. Precipitation editor for all subbasins when the frequency storm method is selected.

The intensity position determines where in the storm the period of peak intensity will occur. Changing the position does not change the total depth of the storm, but does change how the total depth is distributed in time during the storm. You may select 25%, 33%, 50%, 67%, or 75% from the list of choices. If the storm duration is selected to be 6 hours and the 25% position is selected, the peak intensity will occur 1.5 hours after the beginning of the storm. The default selection is 50%.

The storm area is used to automatically compute the depth-area reduction factor. In most cases the specified storm area should be equal to the watershed drainage area at the point of evaluation. The same hyetograph is used for all subbasins. Optionally you may leave the storm area blank. When no storm area is specified, each subbasin will have a different hyetograph computed using the subbasin area as the storm area.

Precipitation depth values must be entered for all durations from the peak intensity to the total storm length. Values for durations less than the peak intensity duration, or greater than the total storm duration are



not entered. The values must be entered according to the selection of annual or partial-duration input. When partial-duration input is selected, the depth-duration values must be entered as partial-duration statistics. When annual-duration input is selected, the depth-duration values must be entered as annual-duration statistics. Values should be entered as the cumulative precipitation depth expected for the specified duration.

The *Component Editor* for each individual subbasin in the meteorologic model is used to specify a separate depth-duration curve for each subbasin (Figure 225). The depth-duration curve can only be entered for a subbasin if the "Curve" option (Figure 224) is set to *Variable by Subbasin*. Using this option may be necessary if the watershed is large and the depth-duration characteristics of the precipitation change significantly over the watershed. For example, mountainous areas may have changes in the precipitation characteristics with changes in elevation.

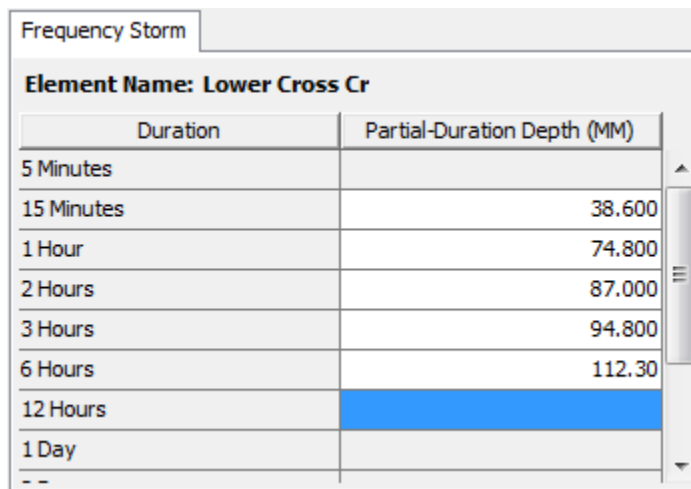

Duration	Partial-Duration Depth (MM)
5 Minutes	
15 Minutes	38.600
1 Hour	74.800
2 Hours	87.000
3 Hours	94.800
6 Hours	112.30
12 Hours	
1 Day	
--	

Figure 225. Entering a separate depth-duration curve for each subbasin.

## Gage Weights

The gage weights method is designed to work with recording and non-recording precipitation gages. Recording gages typically measure precipitation as it occurs and then the raw data are converted to a regular time step, such as 1 hour. Non-recording gages usually only provide an estimate of the total storm depth. The user can choose any method to develop the weights applied to each gage when calculating the hyetograph for each subbasin. For increased flexibility, the total storm depth and the temporal pattern are developed separately for each subbasin. Optionally, an index depth can be assigned to each gage and subbasin. The index is used to adjust for regional bias in annual or monthly precipitation.

The gage weights method includes several options for processing precipitation gage data (Figure 226). The indexing option is used to adjust gage data when there are regional trends in precipitation patterns. Using the index option requires the specification of an index value for each precipitation gage and each subbasin. The average annual precipitation total is often used as the index at a gage, and the estimated average annual precipitation over a subbasin area is often used as the index for a subbasin. Alternately, the monthly average values may be used at each gage and each subbasin. The index values are used to adjust the precipitation data for regional trends before calculating the weighted depth and weighted timing. The total override option is used to adjust the precipitation depth at each gage. Without the override, the total depth at a gage is the sum of the values in the gage record. With the override, the values in the gage record are proportionally adjusted to have a sum equal to the specified total value.

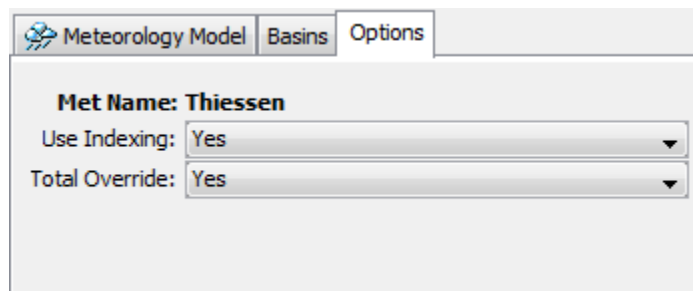

The screenshot shows a software interface with three tabs: 'Meteorology Model', 'Basins', and 'Options'. The 'Options' tab is active. Below the tabs, the text 'Met Name: Thiessen' is displayed. There are two dropdown menus: 'Use Indexing:' with 'Yes' selected, and 'Total Override:' with 'Yes' selected.

Figure 226. Selecting options for the gage weights precipitation method.

The gage weights method includes a *Component Editor* with parameter data for all subbasins in the meteorologic model. A *Component Editor* is also included for specifying the parameter data for precipitation gages. Finally, a separate *Component Editor* is included for each individual subbasin in the meteorologic model. The *Watershed Explorer* provides access to the precipitation component editors using a picture of raindrops, and provides access the gage component editor using a picture of a measurement gage (Figure 227).

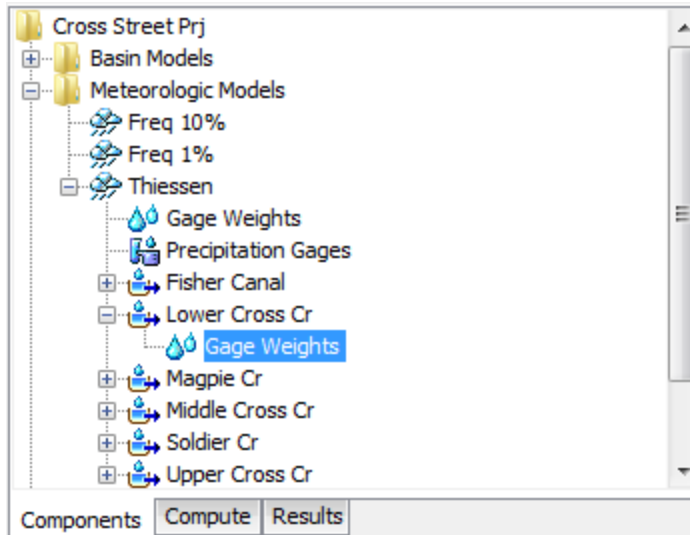

Figure 227. A meteorologic model using the gage weights precipitation method with a component editor for all subbasins, a component editor for precipitation gages, and a separate Component Editor for each individual subbasin.

The *Component Editor* for all subbasins in the meteorologic model includes the optional index for each subbasin. The parameter data for indexing is only entered when the option is activated (Figure 226). In order to use the optional index, an index value must be entered for each subbasin and precipitation gage.

Subbasins	
Met Name: Thiessen	
Subbasin Name	Index (MM)
Upper Cross Cr	988
Magpie Cr	945
Middle Cross Cr	1037
Fisher Canal	966
Soldier Cr	1015
Lower Cross Cr	922

Figure 228. Specifying indices for each subbasin using average annual precipitation depth. Other methods may be used to estimate the index.

The *Component Editor* for all precipitation gages in the meteorologic model includes the optional total depth override and optional indexing. The parameter data for override and indexing is only entered when the respective options are activated (Figure 226). The optional total depth override is entered for each gage (Figure 229). If no total depth is entered, the depth will be the sum of the data actually stored in the

precipitation gage. However, if a total depth is entered, the exact pattern is maintained but the magnitude of precipitation at each time step is adjusted so that the specified depth is applied over the entire simulation. Total depth can be specified for no precipitation gages, one gage, many gages, or all gages. Turning off the "Use Override" option will remove all total depth data for time-series precipitation gages.

Time-Series Gages		Total Storm Gages
<b>Met Name: Thiessen</b>		
Gage Name	Total Depth (MM)	Index (MM)
City Yard (CTYP)		984
Ferry Terminal (FEJP)		992
Fire Dept (FRDP)		1055

Figure 229. Entering optional total depth and index for the precipitation gages.

The optional index is entered for each gage. If you enter an index for a gage, it can only be used during a simulation if you also specify an index for all gages used in a subbasin and also specify an index for the subbasin. Turning off the "Use Indexing" option will remove all indexes from the meteorologic model.

Total storm gages are created and managed directly from the meteorologic manager. To create a new total storm gage, access the "Total Storm Gages" tab and enter a gage name in the first column of the last row (Figure 230). The last row is always kept blank for creating new gages. You can rename a gage by typing over the name in the first column. You can delete a gage by deleting its name from the first column and any data from the other columns. You must always enter a total depth for the gage that represents the total precipitation during the simulation.

Time-Series Gages		Total Storm Gages	
<b>Met Name: Thiessen</b>			
Gage Name	Total Depth (MM)	Index (MM)	
Supplemental 429	37	899	

Figure 230. Creating a total storm gage and entering the total storm depth and optional index.

The *Component Editor* for each subbasin in the meteorologic model is used to select the precipitation gages for that subbasin and to enter weights for each selected gage Figure 231(). The "Gage Selections" tab is where the gages are selected. All of the available gages are shown in a table. The available gages are the precipitation time-series gages defined in the *Time-Series Data Manager* plus any total storm gages defined in the meteorologic model. For each subbasin you must separately select which gages will be used for that subbasin.

The "Gage Weights" tab is where the weights are specified for each gage selected for a subbasin (Figure 232). The gages are shown in a table with a separate row for each gage. Only the gages selected previously on the "Gage Selections" tab are included in the table. For each gage you can enter a depth weight. You can enter a time weight for time-series gages. The values entered for the depth or time weights are automatically normalized during the simulation. The value of the weights must be estimated separate from the program. Possible methods for computing the weights include Thiessen polygons, inverse distance, inverse distance squared, isohyetal mapping, or any method deemed appropriate.

Gage Selections		Gage Weights	
<b>Element Name: Lower Cross Cr</b>			
Gage Name	Use Gage		
City Yard (CTYP)	Yes		
Ferry Terminal (FEJP)	No		
Fire Dept (FRDP)	Yes		
Supplemental 429	Yes		

Figure 231. Selecting which gages to use for a subbasin.

Element Name: Lower Cross Cr		
Gage Name	Depth Weight	Time Weight
City Yard (CTYP)	0.42	0
Fire Dept (FRDP)	0.31	1
Supplemental 429	0.27	

Figure 232. Entering depth and time weights for the selected gages.

### Gridded Precipitation

The gridded precipitation method is designed to work with the ModClark gridded transform. However, it can be used with other area-average transform methods as well. The most common use of the method is to utilize radar-based precipitation estimates. Using additional software, it is possible to develop a gridded representation of gage data or to use output from atmospheric models. If it is used with a transform method other than ModClark, an area-weighted average of the grid cells in the subbasin is used to compute the precipitation hyetograph for each subbasin.

The gridded precipitation method includes a Component Editor with parameter data for all subbasins in the meteorologic model. The Watershed Explorer provides access to the precipitation component editor using a picture of raindrops (Figure 233).

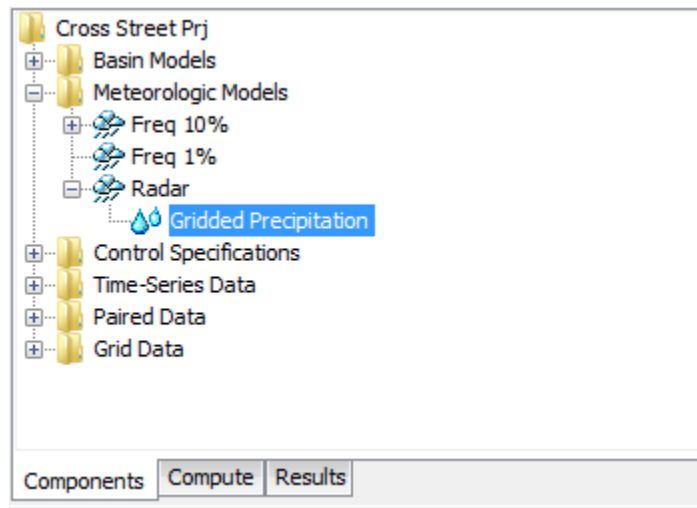

Figure 233. A meteorologic model using the gridded precipitation method with a Component Editor for all subbasins.

The Component Editor for all subbasins in the meteorologic model includes parameter data to describe the gridded precipitation (Figure 234). Gridded precipitation data must be stored as a precipitation grid before it can be used in the meteorologic model. The data may be from radar sources or could be the result of complex calculations exterior to the program. Regardless, the grid data must be stored as a precipitation grid. Only precipitation grids already defined will be shown in the selection list.

Figure 234. Precipitation component editor for the gridded precipitation method.

The time shift can be used to correct for precipitation grids stored with a time zone offset. All calculations during a simulation are computed assuming an arbitrary local time zone that does not observe summer time (daylight savings in the United States). It is common for precipitation data from radar sources to be referenced in Coordinated Universal Time (UTC). Set the shift to zero if all the time-series and grid data is referenced in same local time zone. If other data sources such as observed discharge or temperature are referenced in local time and the precipitation grid is in UTC, select the correct shift so that the precipitation data will match the rest of the data. Local time zones located to the West of the zero longitude line will use a positive shift when the precipitation grid is referenced in UTC. Local time zones located to the East of the zero longitude line will use a negative shift when the precipitation grid is referenced in UTC.

### **HMR 52 Storm**

The HMR 52 storm is one approach to computing the probable maximum precipitation for a watershed as detailed in Hydrometeorological Report No 52 (Hansen, Schreiner, and Miller, 1982). Concentric ellipses are used to construct the storm spatial pattern where each ellipse represents an isohyet of precipitation depth. The storm is located over the watershed by specifying the center of the pattern and the angle of the major axis of the ellipses. Total precipitation depth is computed using a specified storm area and area-

duration precipitation curves. The total precipitation depth is converted to a temporal pattern based on the selected placement of the peak intensity within the storm duration. The most intense 6-hour period of the storm is constructed using the ratio of precipitation depth between the largest and sixth-largest hours.

The precipitation hyetograph for each subbasin is computed by intersecting the polygon outline of the subbasin with the storm. The geometric data for the polygon outline comes from the same source as the Map Objects (See Drawing Elements and Labels). It is optional to use Map Objects for drawing subbasin elements in the Basin Map. However, the Map Objects become required for using the HMR 52 storm.

The HMR 52 storm method includes several parameters to describe the location, orientation, and temporal distribution of the storm plus additional information on the area reduction (Figure 235). The X and Y coordinate parameters are used to specify the center of the storm pattern. The coordinate values should be entered using the same coordinate system as the geometric data for the subbasin polygons. The preferred orientation is measured in degrees increasing clockwise from north. The actual orientation is also measured in degrees increasing clockwise from North. Following guidelines in Hydrometeorological Report No 52, a reduction is applied when the actual orientation deviates from the preferred orientation by more than 40 degrees.

Precipitation	
<b>Met Name: HMR 52</b>	
*X Coordinate:	637992.828
*Y Coordinate:	4075751.512
*Preferred Orientation (DEG)	210
*Orientation (DEG)	250
*Peak Intensity:	Hours 42 to 48
*1 to 6 Ratio:	0.285
*Area (MI2)	10000
Area (MI2)	Duration-Precip
10	Area 10
200	Area 200
1,000	Area 1000
5,000	Area 5000
10,000	Area 10000
20,000	Area 20000

Figure 235. Precipitation component editor for the HMR 52 storm.



The HMR 52 storm is 72 hours long and begins at the simulation start time. The peak intensity parameter specifies the period within the 72-hour storm when the precipitation rate will be greatest. The 6-hour period of peak intensity can be set to begin as early as hour 24 of the storm or as late as hour 60 of the storm. The depth of rain falling during the period of peak intensity is subdivided into 1-hour increments using the parameter for the ratio of the 1-hour to 6-hour depth.

The total storm area must be specified. Additionally, a duration-precipitation function must be selected for the range of possible storm areas. In general, the curves are constructed using data available in Hydrometeorological Report No 51 (Schreiner and Riedel, 1978). Each duration-precipitation function must be defined in the paired data manager before it can be selected. You can press the paired data button next to the selection list to use a chooser. The chooser shows all of the available duration-precipitation functions in the project.

The HMR 52 storm method creates a storm from input specified by the user including storm center, orientation, and area. A new analysis tool is under development which would automatically select these three parameters in order to maximize precipitation volume over the watershed, or peak runoff, or volume, or reservoir pool elevation.

### ***Inverse Distance***

The inverse distance method was originally designed for application in real-time forecasting systems. It can use recording gages that report on a regular interval like 15 minutes or 1 hour. It can also use gages that only report daily precipitation totals. Because it was designed for real-time forecasting, it has the ability to automatically switch from using close gages to using more distant gages when the closer gages stop reporting data. The latitude and longitude of the gages is used to determine closeness to one or more nodes specified in each subbasin. The distance at which gages are used for a subbasin is controlled by the search distance. Optionally, an index depth can be assigned to each gage and subbasin node. The index is used to adjust for regional bias in annual or monthly precipitation.

The inverse distance method includes several options for processing precipitation gage data (Figure 236). The indexing option is used to adjust gage data when there are regional trends in precipitation patterns. Using the index option requires the specification of an index value for each precipitation gage and each node in each subbasin. The average annual precipitation total is often used as the index at a gage, and the estimated average annual precipitation at a node location is often used as the index for a subbasin node. Alternately, the monthly average values may be used at each gage and each node. The search distance option can be used to limit the influence distance

of precipitation gages. When no search distance is specified, the default value of 1,000 kilometers is used. When an optional distance is entered, gages are only used at a subbasin node if they are within the specified distance.

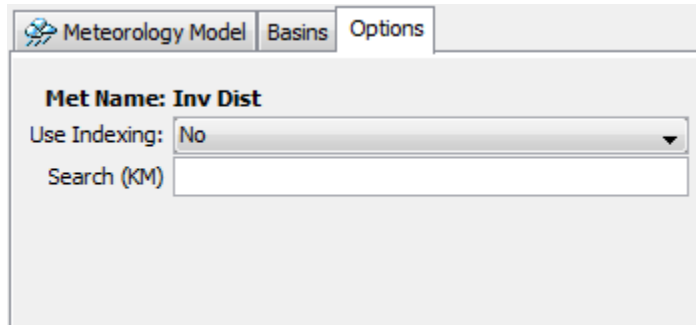

Figure 236. Selecting options for the inverse distance precipitation method.

The inverse distance method includes a *Component Editor* for specifying the parameter data for precipitation gages. A *Component Editor* is also included for each individual subbasin in the meteorologic model. The *Watershed Explorer* provides access to the gage component editor using a picture of a measurement gage, and provides access to the precipitation component editor for each subbasin with a picture of raindrops (Figure 237).

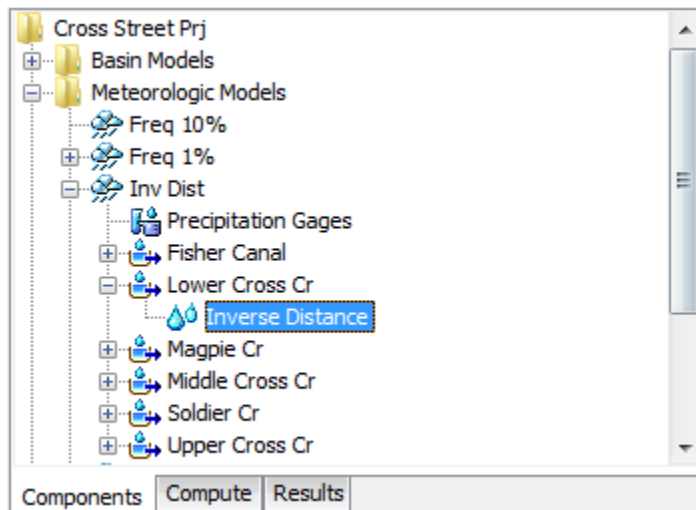

Figure 237. A meteorologic model using the inverse distance precipitation method with a component editor for precipitation gages and a separate component editor for each individual subbasin.

The *Component Editor* for all precipitation gages in the meteorology model is used to select gages for processing, control how they are processed, and enter optional indexing parameter data (Figure 238). All gages used in the inverse distance method must be setup in the *Time-Series Data Manager* before they can be used. The *Component Editor* will subsequently show all available precipitation gages. You

may determine which gages will be used in the meteorology model by setting the appropriate choice in the "Use Gage" column.

Time-Series Gages			
Met Name: Inv Dist			
Gage Name	Use Gage	Daily Gage	Index (MM)
City Yard (CTYP)	Yes	No	984
Ferry Terminal...	Yes	No	992
Fire Dept (FRDP)	Yes	No	1055

*Figure 238. Selecting which time-series gages to use for a subbasin included in a meteorologic model with the inverse distance precipitation method selected. The index precipitation is optional.*

Each precipitation gage may use any of the allowable time intervals from 1 minute to 24 hours. When a gage is selected as a daily gage, it is assumed during calculations that the daily precipitation depth is known but there is no timing information. Usually daily gages are stored with a 24-hour time interval, but any interval may be used. Daily gage data is only used during processing for days where the entire day is within the simulation time window. When a gage is not selected as a daily gage, the data it contains is interpolated to the simulation time step. The appropriate setting should be made in the "Daily Gage" column.

The optional index is entered for each gage. If you enter an index for a gage, it can only be used during a simulation if you also specify an index for all gages used in a subbasin and also specify an index for each node in that subbasin. Turning off the "Use Indexing" option will remove all indexes from the meteorologic model.

The *Component Editor* for each subbasin in the meteorologic model is used to create one or more nodes and enter the coordinates for each node (Figure 239). A minimum of one node is required. To create a new node, access the "Node Weights" tab and enter a node name in the first column of the last row. The last row is always kept blank for creating new nodes. You can rename a node by typing over the name in the first column. You can delete a node by deleting its name from the first column and any data from the other columns. You must always enter a weight for a node. The weight controls how the final hyetograph is computed for the subbasin from the hyetographs computed at each node. If you have enabled the indexing option, you should also enter the index for each node. The index is used to adjust for regional bias in annual or monthly precipitation.

All nodes that you have created will be shown on the "Latitudes" and "Longitudes" tabs. You must enter the appropriate coordinate information for each node. Coordinates may be entered using degree-minute-second format or alternately may be entered using decimal degree format. The data entry format is selected in the *Program Settings*.

Node Weights		
Latitudes	Longitudes	
<b>Element Name: Lower Cross Cr</b>		
Node Name	Weight	Index (MM)
Centroid	1.0	953

Figure 239. Creating an inverse distance node in a subbasin.

## SCS Storm

The Soil Conservation Service (SCS) storm method implements the design storm patterns developed developed for use in rural, agricultural watersheds (NRCS, 2007). The original methodology was developed to provide guidance when designing safe water storage facilities for agricultural applications. However, the storm has been applied in a variety of other situations. The same hyetograph is computed for all subbasins.

The SCS storm method includes a *Component Editor* with parameter data for all subbasins in the meteorologic model. The *Watershed Explorer* provides access to the precipitation component editor using a picture of raindrops (Figure 240).

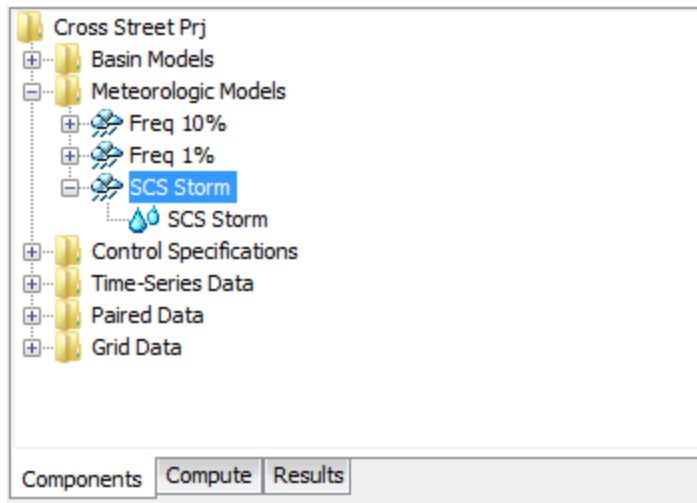

Figure 240. A meteorologic model using the SCS storm precipitation method with a component editor for all subbasins.

The *Component Editor* for all subbasins in the meteorologic model specifies the parameter data for the storm (Figure 241). Each storm has only one time distribution type which must be selected from the list of available choices. The available types are Type 1, Type 1A, Type 2, and Type 3. Each storm is 24 hours long. The simulation must have a duration of 24 hours or longer. All precipitation values after the first 24 hours will be zero.

Each storm has the same total precipitation depth for every subbasin in the meteorologic model. There is no depth-area reduction or any other kind of reduction or modification performed on the specified depth. The specified depth is applied to the selected time distribution type to generate the hyetograph for each subbasin.

Figure 241. Precipitation component editor for the SCS storm precipitation method.

### **Specified Hyetograph**

The specified hyetograph method allows the user to specify the exact time-series to use for the hyetograph at subbasins. This method is useful when precipitation data will be processed externally to the program and essentially imported without alteration. This method is

also useful when a single precipitation gage can be used to represent what happens over a subbasin.

The specified hyetograph method includes an option for processing precipitation gage data (Figure 242). The total override option is used to adjust the precipitation depth at each gage. Without the override, the total depth at a gage is the sum of the values in the gage record. With the override, the values in the gage record are proportionally adjusted to have a sum equal to the specified total value.

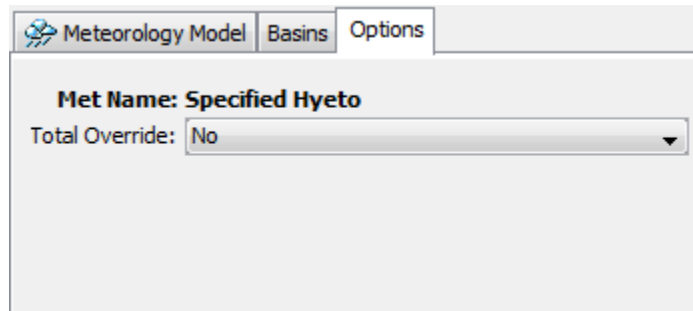

Figure 242. Selecting options for the specified hyetograph precipitation method.

The specified hyetograph method uses a *Component Editor* with parameter data for all subbasins in the meteorological model. The *Watershed Explorer* provides access to the component editor using a picture of raindrops (Figure 243).

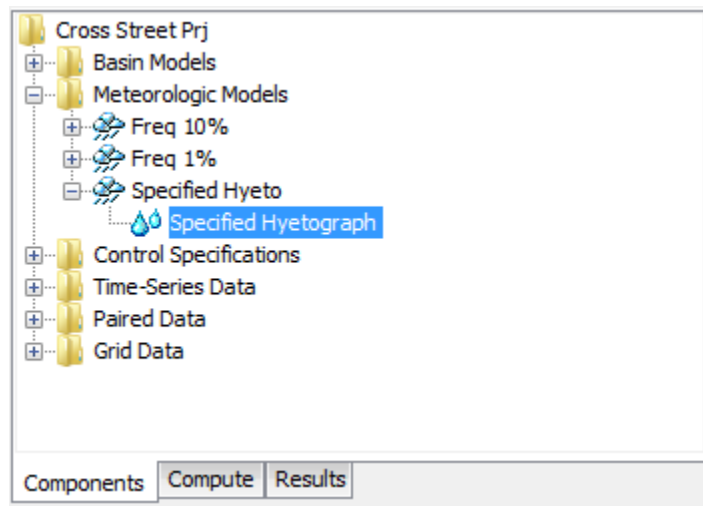

Figure 243. A meteorologic model using the specified hyetograph precipitation method with a component editor for all subbasins.

The *Component Editor* for all subbasins in the meteorologic model includes the gage selection for each subbasin and the optional depth override for each subbasin (Figure 244). A hyetograph must be stored as a precipitation gage before it can be used in the meteorologic

model. The data may actually be from a recording gage or could be the result of complex calculations exterior to the program. Regardless, the hyetograph must be stored as a gage. You may use the same gage for more than one subbasin. For each subbasin in the table, select the gage to use for that subbasin. Only precipitation gages already defined in the *Time-Series Data Manager* will be shown in the selection list.

Subbasins		
Met Name: Specified Hyeto		
Subbasin Name	Gage	Total Depth (MM)
Fisher Canal	City Yard (CTYP)	
Lower Cross Cr	Ferry Terminal (FEJP)	
Magpie Cr	Fire Dept (FRDP)	67
Middle Cross Cr	Ferry Terminal (FEJP)	
Soldier Cr	Ferry Terminal (FEJP)	
Upper Cross Cr	City Yard (CTYP)	

Figure 244. Selecting a gage for each subbasin. Total depth override is optional.

Optionally, you may enter a total depth for each subbasin. If no total depth is entered, the depth will be the sum of the data actually stored in the precipitation gage. However, if a total depth is entered for a subbasin, the exact pattern is maintained but the magnitude of precipitation at each time step is adjusted proportionally so that the specified depth is applied over the entire simulation. Total depth can be specified for no subbasins, one subbasin, many subbasins, or all subbasins. It is not required to enter the depth for all subbasins in order to specify it for just one subbasin.

### **Standard Project Storm**

The standard project storm method implements the requirements of Engineering Manual EM-1110-2-1411 (Corps 1965). While the methodology is no longer frequently used, it is included in the program for projects where it may still be necessary.

The standard project storm method includes a *Component Editor* with parameter data for all subbasins in the meteorologic model. The *Watershed Explorer* provides access to the precipitation component editors using a picture of raindrops (Figure 245).

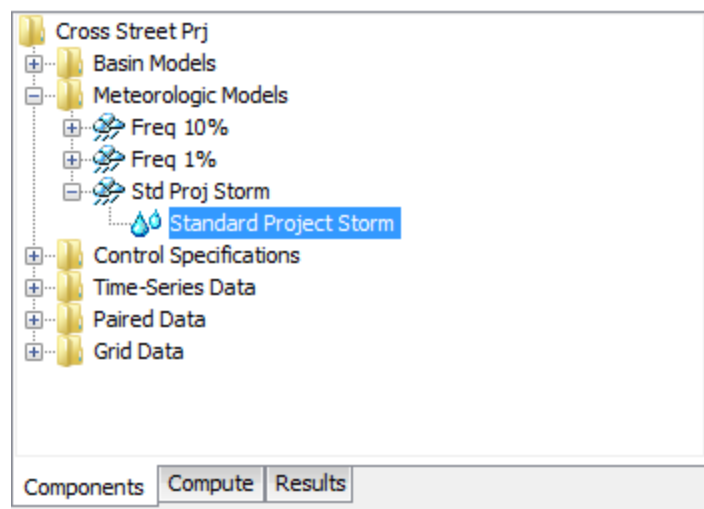

Figure 245. A meteorologic model using the standard project storm method with a component editor for all subbasins.

The *Component Editor* for all subbasins in the meteorologic model includes parameter data to describe the storm (Figure 246). The precipitation index represents the depth of rainfall during the storm. This index is not the same as the probable maximum precipitation and does not have an associated exceedance probability. The index is selected from a map in the Engineering Manual.

The storm area is used to automatically compute the depth-area reduction factor, based on figures in the Engineering Manual. In most cases the specified storm area should be equal to the watershed drainage area at the point of evaluation.

The distribution determines how the adjusted precipitation depth for each subbasin is shaped into a hyetograph; it must be selected from the list of available choices. The *Standard* option uses the procedure specified in the Engineering Manual to distribute the adjusted storm depth. The *Southwest Division* option uses a different procedure that may be more applicable in some watersheds.

The transposition factor accounts for the location of a subbasin in the watershed, relative to the center of the storm (Figure 247). The Engineering Manual contains an isohyetal map with concentric rings labeled in percent. If a subbasin is generally covered by the 120% isohyetal line, then a factor of 1.20 should be entered in the program.



Precipitation Subbasins

**Met Name: Std Proj Storm**

\*Index (MM) 354

\*Area (KM2) 45.6

Distribution: Standard

Figure 246. Entering properties of the standard project storm.

Precipitation Subbasins

**Met Name: Std Proj Storm**

Subbasin Name	Transposition Factor
Upper Cross Cr	1.4
Magpie Cr	1.41
Middle Cross Cr	1.25
Fisher Canal	1.22
Soldier Cr	1.10
Lower Cross Cr	1.16

Figure 247. Entering a transposition factor for each subbasin.

## Evapotranspiration

Evapotranspiration is the combination of evaporation from the ground surface and transpiration by vegetation. It includes both evaporation of free water from the surface of vegetation and the land surface. It also includes transpiration which is the process of vegetation extracting it from the soil through the plant root system. Whether by evaporation or transpiration, water is returned from the land surface or subsurface to the atmosphere. Even though evaporation and transpiration are taken together, transpiration is responsible for the movement of much more water than evaporation. Combined evapotranspiration is often responsible for returning 50 or even 60% of precipitation back to the atmosphere. The theoretical evapotranspiration, also called the potential evapotranspiration, serves as the upper limit for what can happen on the land surface based on atmospheric conditions. In all cases, the meteorologic model is computing the potential evapotranspiration and subbasins will calculate actual evapotranspiration based on soil water limitations.

The evapotranspiration method included in the meteorologic model is only necessary when using continuous simulation loss rate methods in subbasins: deficit constant, gridded deficit constant, soil moisture

accounting, and gridded soil moisture accounting. If a continuous simulation loss rate method is used and no evapotranspiration is specified in the meteorologic model, then zero potential evapotranspiration is used in the subbasins. The options for evapotranspiration include a physically-based energy balance model (Penman Monteith), a simplified physically-based model (Priestley Taylor), and a simple monthly average approach. A specified method is also included so that evapotranspiration can be calculated external to the program and imported. Each option produces the potential evapotranspiration rate over the land surface where it can be used in the subbasin element to compute evaporation from the canopy and surface, and transpiration from the soil. More detail about each method is provided in the following sections.

### **Annual Evapotranspiration**

The annual evapotranspiration method is designed to work with a maximum daily rate combined with an optional pattern of variation throughout the year. Specifying only a daily rate can produce good results for simulations lasting days to weeks if evapotranspiration is fairly consistent each day. The optional pattern can be used to adjust the applied evapotranspiration rate during simulations lasting weeks to years.

The annual evapotranspiration method includes a *Component Editor* with parameter data for all subbasins in the meteorologic model. The Watershed Explorer provides access to the evapotranspiration component editor using a picture of a water pan.

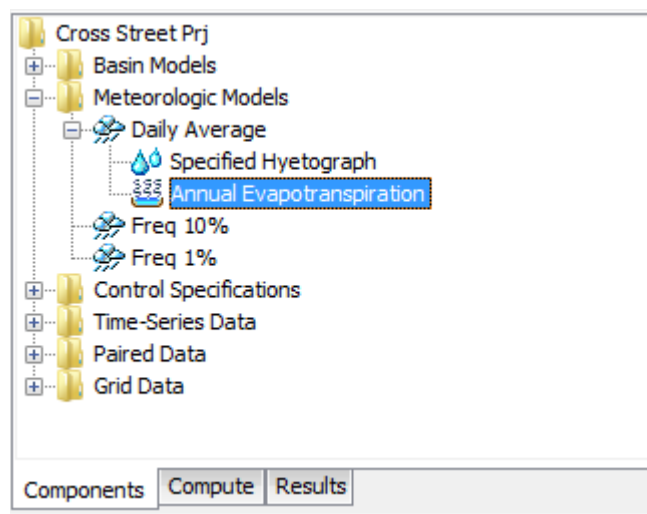

*Figure 248. A meteorologic model using the annual evapotranspiration method with a single component editor for all subbasins.*

The *Component Editor* for all subbasins in the meteorologic model includes the daily rate and optional pattern for each subbasin. When

the optional percentage pattern is not used, the value entered for the daily rate should generally be the average daily potential evapotranspiration rate over the duration of the simulation. When a pattern will be added, the value entered for the daily rate should generally be the largest potential evapotranspiration for any day occurring during the simulation.

Annual Evapotranspiration		
Met Name: Daily Average		
Subbasin Name	Rate (MM/DAY)	Percent Pattern
Fisher Canal	5.6	ET Pattern
Lower Cow Cr	5.6	ET Pattern
Lower Cross Cr	6.1	ET Pattern
Magpie Cr	5.6	ET Pattern
Middle Cross Cr	6.1	ET Pattern
Upper Cow Cr	5.6	ET Pattern
Upper Cross Cr	6.1	ET Pattern

Figure 249. Entering rates and selecting a percent pattern for each subbasin.

The optional pattern is specified as a percent pattern in the paired data manager. The evapotranspiration for each day of the simulation is computed by multiplying the entered rate by the percentage interpolated from the percent pattern. The available percent patterns are shown in the selection list. If there are many different patterns available, you may wish to choose a pattern from the selector accessed with the paired data button next to the selection list. The selector displays the description for each percent pattern, making it easier to select the correct one.

### **Gridded Penman Monteith**

The gridded Penman Monteith method is designed to work with the gridded ModClark transform method. It is the same as the regular Penman Monteith method (described in a later section) except that the Penman Monteith equations are applied to each grid cell using separate boundary conditions instead of area-averaged values over the whole subbasin. Shortwave and longwave radiation are inputs to the Penman Monteith method so both a gridded shortwave radiation method and a gridded longwave radiation method should also be selected in the meteorologic model.

The gridded Penman Monteith method includes a *Component Editor* with parameter data for all subbasins in the meteorologic model. The *Watershed Explorer* provides access to the evapotranspiration component editor using a picture of a water pan (Figure 250).

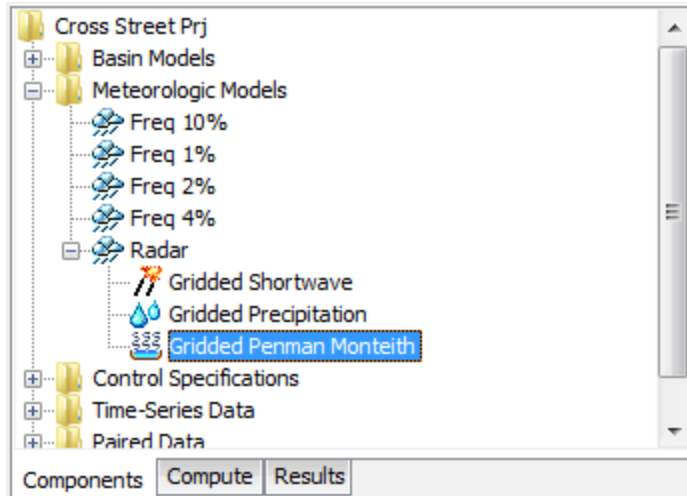

Figure 250. A meteorologic model using the gridded Penman Monteith evapotranspiration method with a component editor for all subbasins.

The *Component Editor* for all subbasins in the meteorologic model includes parameter grids for the atmospheric variables required in the Penman Monteith equations (Figure 251). A temperature gridset must be selected for all subbasins. The current gridsets are shown in the selection list. If there are many different gridsets available, you may wish to choose a gridset from the selector accessed with the grid button next to the selection list. The selector displays the description for each gridset, making it easier to select the correct one. A gridset is also required for windspeed. Finally, a gridset is required for either dew point temperature or relative humidity. Select the vapor pressure type you wish to use, and then select the appropriate gridset.

A reference albedo is required for computing the energy balance at the ground surface. The same value is applied to all grid cells in all subbasins. A default value of 0.23 is widely used.

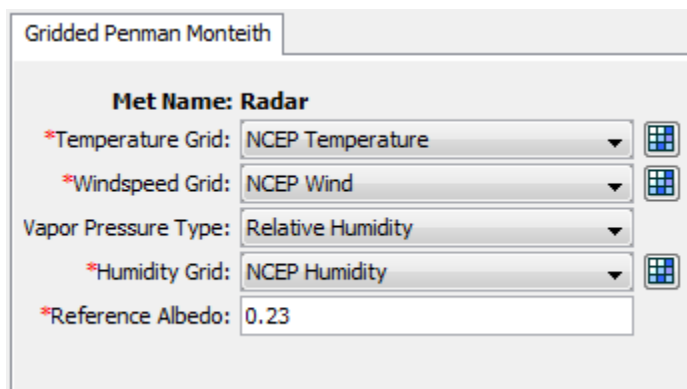

Figure 251. Component editor for the gridded Penman Monteith evapotranspiration method.

## Gridded Priestley Taylor

The gridded Priestley Taylor method is designed to work with the gridded ModClark transform method. It is the same as the regular Priestley Taylor method (described in a later section) except the Priestley Taylor equations are applied to each grid cell using separate boundary conditions instead of area-averaged values over the whole subbasin. Net shortwave radiation is an input to the Priestley Taylor method so a gridded shortwave radiation method should also be selected in the meteorologic model.

The gridded Priestley Taylor method includes a *Component Editor* with parameter data for all subbasins in the meteorologic model. The *Watershed Explorer* provides access to the evapotranspiration component editor using a picture of a water pan (Figure 252).

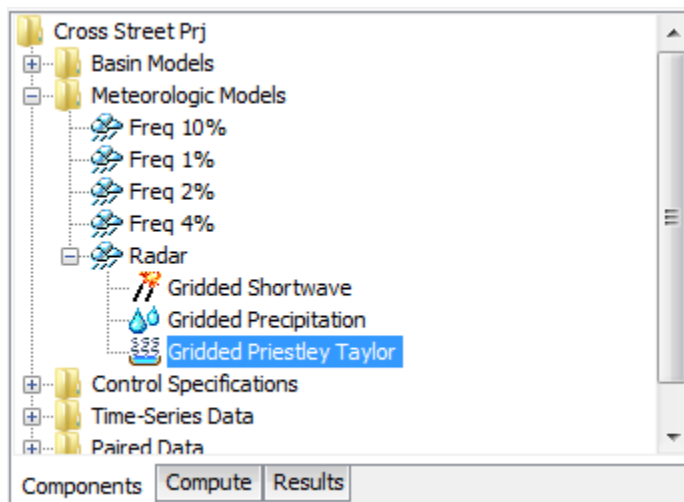

Figure 252. A meteorologic model using the gridded Priestley Taylor evapotranspiration method with a component editor for all subbasins.

The *Component Editor* for all subbasins in the meteorologic model includes a dryness coefficient which must be entered for all subbasins (Figure 253). The same coefficient is applied to all grid cells in all subbasins. The coefficient is used to make small corrections based on soil moisture state. A coefficient should be specified that represents typical soil water conditions during the simulation. A value of 1.2 can be used in humid conditions while a value of 1.3 represents an arid environment.

A temperature gridset must be selected for all subbasins. The current gridsets are shown in the selection list. If there are many different gridsets available, you may wish to choose a gridset from the selector accessed with the grid button next to the selection list. The selector

displays the description for each gridset, making it easier to select the correct one.

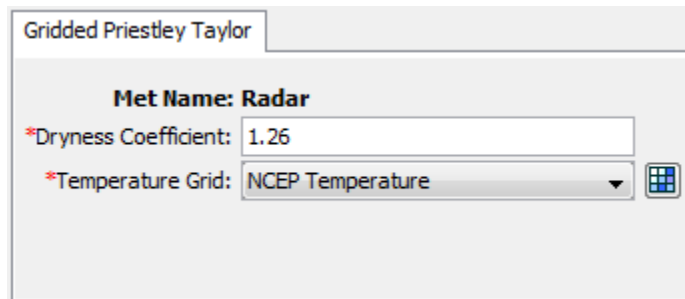

Figure 253. Component editor for the gridded Priestley Taylor evapotranspiration method.

## Monthly Average

The monthly average method is designed to work with measured pan evaporation data. However, it can also be used with data collected with the eddy correlation technique or other modern methods. Regardless of how they are collected, the data are typically presented as the average depth of evaporated water each month. Maps or tabular reports can be found for each month and used with this method.

The monthly average method includes a *Component Editor* with parameter data for each individual subbasin in the meteorologic model. The *Watershed Explorer* provides access to the evapotranspiration component editor using a picture of a water pan (Figure 254).

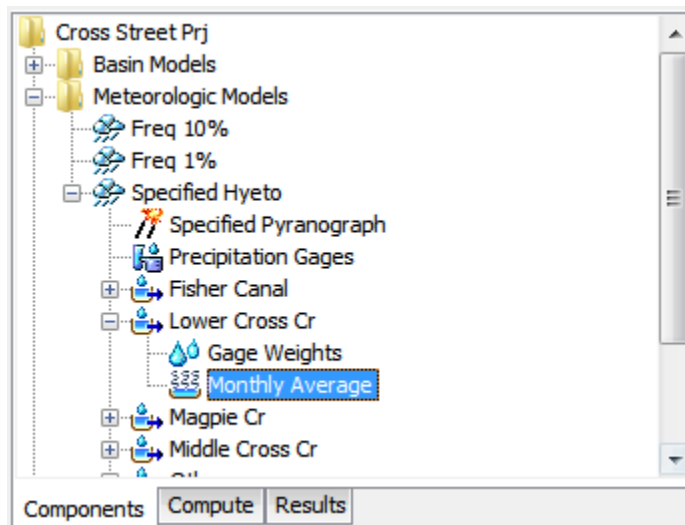

Figure 254. A meteorologic model using the monthly average evapotranspiration method with a separate component editor for each individual subbasin.

The *Component Editor* for each subbasin includes the evapotranspiration rate for each month of the year (Figure 255). It is entered as the total amount of evapotranspiration for the month. Every time step within the month will have the same evapotranspiration rate.

The pan coefficient must also be entered for each month. The specified rate is multiplied by the coefficient to determine the final potential rate for each month. The coefficient is usually used to correct actual evaporation pan data to more closely reflect plant water use.

The screenshot shows a window titled 'Monthly Average' with a sub-header 'Met Name: Specified Hyeto'. Below this is a table with three columns: 'Month', 'Rate (MM/MONTH)', and 'Coefficient'. The table contains data for the months of January through August. The 'Rate' values are 56, 71, 115, 134, 180, 177, 173, and 161 respectively. The 'Coefficient' is constant at 0.7 for all months. The table is part of a larger interface with scroll bars on the right.

Month	Rate (MM/MONTH)	Coefficient
January	56	0.7
February	71	0.7
March	115	0.7
April	134	0.7
May	180	0.7
June	177	0.7
July	173	0.7
August	161	0.7

Figure 255. Entering rate and pan coefficient data for a subbasin in a meteorologic model using the monthly average evapotranspiration method.

## Penman Monteith

The Penman Monteith method implements the Penman Monteith equations for computing evapotranspiration at less than a daily time interval as detailed by Allen, Pereira, Raes, and Smith (1998). The equations are based on a combination of an energy balance with a mass transfer. The maximum possible evapotranspiration is moderated by an aerodynamic resistance due to friction as air flows over the vegetation. A bulk surface resistance is added in series with the aerodynamic resistance to account for limitations to water vapor flow at the leaf surfaces and at the soil. The parameterization is entirely dependent on the atmospheric conditions.

The Penman Monteith method requires shortwave radiation and longwave radiation be included in the meteorologic model. The algorithm of Allen, Pereira, Raes, and Smith (1998) is followed most closely when the FAO56 shortwave method and the FAO56 longwave method are selected.

The Penman Monteith method includes a *Component Editor* with parameter data for each individual subbasin in the meteorologic model.

The *Watershed Explorer* provides access to the evapotranspiration component editor using a picture of a water pan (Figure 256).

An air temperature gage and a windspeed gage must be selected in the atmospheric variables for each subbasin. Additionally, the water vapor must be specified with either a relative humidity or dew point temperature gage.

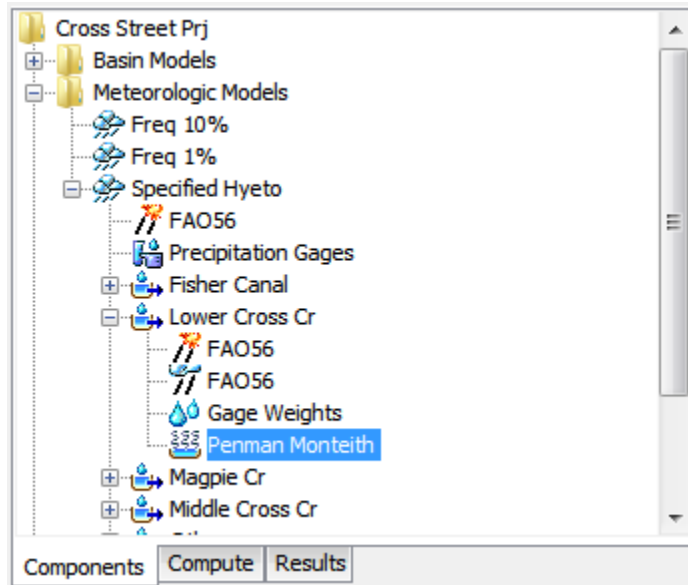

Figure 256. A model using the Penman Monteith evapotranspiration method with a component editor for each individual subbasin.

The *Component Editor* for each subbasin includes atmospheric parameter data for use in the Penman Monteith equations (Figure 257). A reference albedo is required for computing the energy balance at the ground surface. A default value of 0.23 is widely used.

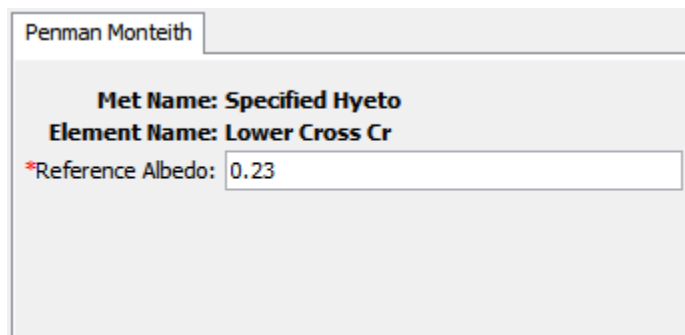

Figure 257. Entering Penman Monteith properties for a subbasin.

### **Priestley Taylor**

The Priestley Taylor method (Priestley and Taylor, 1972) uses a simplified energy balance approach where the soil water supply is assumed to be unlimited. Simplified forms of latent and sensible



energy are used. The method is capable of capturing diurnal variation in potential evapotranspiration through the use of a net solar radiation gage, so long as the simulation time step is less than 24 hours. A non-gridded shortwave radiation method should be selected in the meteorologic model. The shortwave radiation method should be configured to provide the net radiation; this is usually accomplished by computing the required value externally and inputting it using a radiation time-series gage.

The Priestley Taylor method includes a *Component Editor* with parameter data for each individual subbasin in the meteorologic model. The *Watershed Explorer* provides access to the evapotranspiration component editor using a picture of a water pan (Figure 258).

An air temperature gage must be selected in the atmospheric variables for each subbasin.

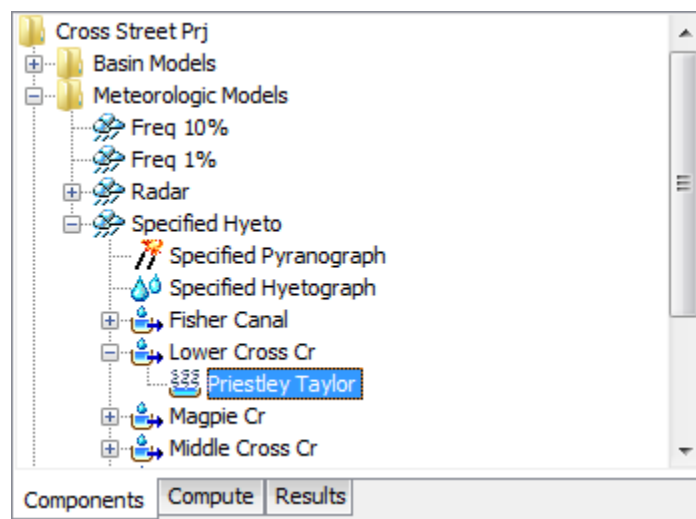

Figure 258. A meteorologic model using the Priestley Taylor evapotranspiration method with a component editor for each individual subbasin.

The *Component Editor* for each subbasin includes a dryness coefficient (Figure 259). The coefficient is used to make small corrections based on soil moisture state. A coefficient should be specified that represents typical soil water conditions during the simulation. A value of 1.2 can be used in humid conditions while a value of 1.3 represents an arid environment.

Priestley Taylor

**Met Name: Specified Hyeto**  
**Element Name: Lower Cross Cr**

\*Dryness Coefficient: 1.26

Figure 259. Entering Priestley Taylor properties for a subbasin.

## Specified Evapotranspiration

The specified evapotranspiration method allows the user to specify the exact time-series to use for the potential evapotranspiration at subbasins. This method is useful when atmospheric and vegetation data will be processed externally to the program and essentially imported without alteration. This method is also useful when a single evapotranspiration observation measurement can be used to represent what happens over a subbasin.

The specified evapotranspiration method uses a *Component Editor* with parameter data for all subbasins in the meteorological model. The *Watershed Explorer* provides access to the gage component editor using a picture of a water pan (Figure 260).

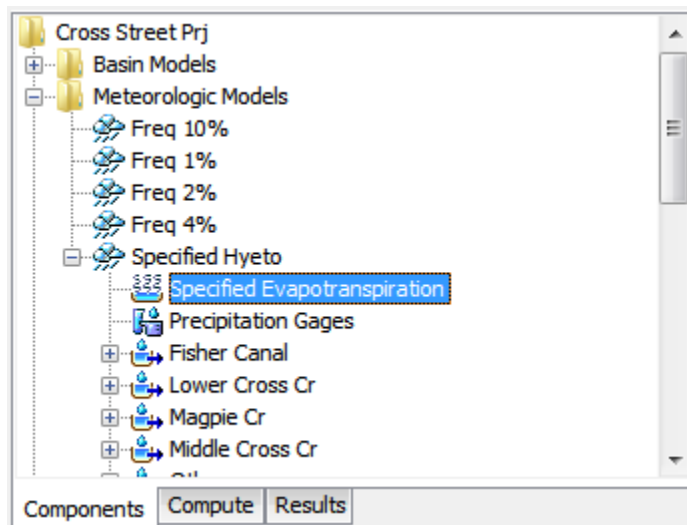

Figure 260. A meteorologic model using the specified evapotranspiration method with one component editor for subbasins.

The *Component Editor* for all subbasins in the meteorologic model includes the gage selection for each subbasin (Figure 261). An evapotranspiration time-series must be stored as an evapotranspiration gage before it can be used in the meteorologic

model. The data may actually be from daily pan measurements, hourly eddy covariance measurements, or could be the result of complex calculations exterior to the program. Regardless, the time-series must be stored as a gage. You may use the same gage for more than one subbasin. For each subbasin in the table, select the gage to use for that subbasin. Only evapotranspiration gages already defined in the *Time-Series Data Manager* will be shown in the selection list.

Specified Evapotranspiration	
Met Name: Specified Hyeto	
Subbasin Name	Gage
Fisher Canal	KJ2 Tower
Lower Cross Cr	KTT Tower
Magpie Cr	KTT Tower
Middle Cross Cr	KJ2 Tower
Soldier Cr	KJ2 Tower
Upper Cross Cr	KJ2 Tower

Figure 261. Selecting a time-series gage for each subbasin in a meteorologic model using the specified evapotranspiration method.

## Snowmelt

Precipitation generally occurs as snow when the air temperature over the land surface is below the freezing point. In general the snow will accumulate on the land surface so long as the air temperature remains below the freezing point. In some watersheds it is part of the annual hydrologic cycle that snowfall accumulates in a snowpack during the winter months. Snowpacks are not static but undergo continual ice crystal transformations in response to diurnal temperature fluctuations. Ablation or melting of the snowpack occurs when atmospheric conditions transfer energy sufficient to raise the temperature of the snowpack to the freezing point, and then transform the snow to liquid water through the heat of fusion for ice. The most common way to measure the water content of the snowpack is by the snow water equivalent or SWE. The SWE is the depth of water that results from melting a unit column of the snowpack.

The snowmelt method included in the meteorologic model is only necessary when the air temperature may be below the freezing point during a simulation, or a snowpack may exist at the beginning of a simulation. Currently the only option available is a temperature index approach that includes a conceptual representation of the snowpack energy. It computes the liquid water available at the soil surface which

is then subject to infiltration and surface runoff. A physically-based energy balance option is under development for a future version.

### **Gridded Temperature Index**

The gridded temperature index method is designed to work with the gridded ModClark transform method. It is the same as the regular temperature index method except the equations for simulating the snowpack are computed separately for each grid cell with separate precipitation and temperature boundary conditions instead of area-averaged values over the whole subbasin. This method can only be used if gridded precipitation is also used. If it is used with a transform method other than ModClark, an area-weighted average of the grid cells in the subbasin is used to compute the boundary condition of the subbasin.

The gridded temperature index method includes a *Component Editor* with parameter data for all subbasins in the meteorologic model. The *Watershed Explorer* provides access to the snowmelt component editor using a picture of a snowflake (Figure 262).

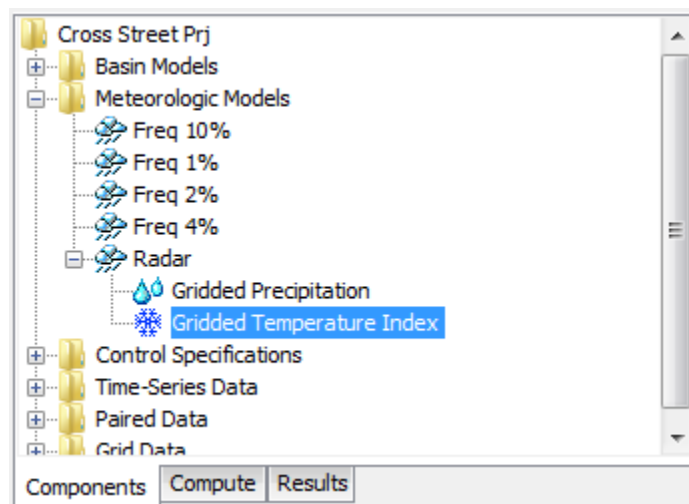

Figure 262. A meteorologic model using the gridded temperature index snowmelt method with a component editor for all subbasins.

The *Component Editor* for all subbasins includes the specification of temperature and initial condition data (Figure 263). A temperature gridset must be selected as the atmospheric boundary conditions on the model. The current gridsets are shown in the selection list. If there are many different gridsets available, you may wish to choose a gridset from the selector accessed with the grid button next to the selection list. The selector displays the description for each gridset, making it easier to select the correct one. The time shift can be used to correct for temperature grids stored with a time zone offset. All calculations during a simulation are computed assuming an arbitrary local time

zone that does not observe summer time (daylight savings in the United States). In some cases, the temperature data may be stored in universal time, also known as Greenwich Mean Time (GMT). If the simulation will happen in a local time zone because of other data sources such as observed discharge, select the correct shift so that the temperature data will match the rest of the data. For local time zones West of the zero longitude line, the shift will be negative. For local time zones East of the zero longitude line, the shift will be positive.

**Gridded Temperature Index**

**Met Name: Radar**

\*Temperature Gridset: NCEP Temperature

Time Shift (HR): -6

Initial Values: Parameter Grids

\*Initial SWE Grid: SWE 0203

\*Initial CC Grid: CC 0203

\*Initial Liquid Grid: LWC 0203

\*Initial CC ATI Grid: CCati 0203

\*Initial Melt ATI Grid: INITati 0203

\*PX Temperature (C): 0.8

\*Base Temperature (C): 0.0

\*Wet Meltrate (MM/DEG C-DAY): 3.3

Rain Rate Limit (MM/DAY): 1.0

ATI-Meltrate Coefficient: 0.98

\*ATI-Meltrate Function: Default ati-melt

Meltrate Pattern: --None--

Cold Limit (MM/DAY): 1.2

ATI-Coldrate Coefficient: 0.84

ATI-Coldrate Function: Default ati-cc

Water Capacity (%): 3

Groundmelt Method: Fixed Value

Groundmelt (MM/DAY): 0

Figure 263. Component editor for the gridded temperature index snowmelt method.

The initial values can be specified with gridsets, or can be initialized to default values. All cells in each subbasin are set to the same default value when the `Default Values` option is chosen. The default values are: initial SWE of 0mm, initial cold content of 0mm, initial liquid of 0%, initial cold content ATI of 0C, and initial meltrate ATI of 0 DegC-day. Five parameter grids must be selected when the `Parameter`

`Grids` option is selected; the grids are described in the following paragraphs.

The initial snow water equivalent that exists at the beginning of the simulation must be entered. This information is usually determined by interpolating from actual measurements of snow water equivalent. This value can be set to zero if there is no snow.

The initial cold content that exists at the beginning of the simulation must be entered. It represents the heat required to raise the temperature of the snow pack to 0C (32F) and is expressed as a number equivalent to mm (inches) of frozen water. If there is no snow at the beginning of the simulation, it can be set to zero. If there is a snowpack, it can be estimated as the depth of snow multiplied by the snow density multiplied by the heat capacity of snow multiplied by the number of degrees below the freezing point.

The liquid water held within the snowpack at the beginning of the simulation must be entered. Liquid water can persist in the snow only if the snowpack temperature is at 0C (32F). There are few conditions when this value can be exactly known. One case is when there is no snowpack and it can be set to zero. A second case is when the air temperature has been continually below freezing for several days and it can be set to zero.

The initial cold content antecedent temperature index is an index to the snow temperature near the surface of the snowpack. It should be set to the approximate snowpack temperature at the beginning of the simulation. If the initial temperature is not known, it can be set to 0C (32F).

The seasonal variation of melt rate is indexed by an antecedent temperature function. The initial melt rate ATI should be thought of as similar to "the accumulated thawing degree days." This antecedent temperature function allows the melt rate to change as the snowpack matures and ages. If there is no snow on the ground at the start of the simulation this term can be set to zero. It can also be set to zero if the simulation is starting during or at the end of a cold period when air temperatures were continually below the base temperature. Otherwise it must be calculated as the accumulation of degree-days since the last period of sustained air temperature below freezing.

The PX temperature is used to discriminate between precipitation falling as rain or snow. When the air temperature is less than the specified temperature, any precipitation is assumed to be snow. When the air temperature is above the specified temperature, any precipitation is assumed to be rain. This discrimination temperature may be up to 1C.

The difference between the base temperature and the air temperature defines the temperature index used in calculating snowmelt. The meltrate is multiplied by the difference between the air temperature and the base temperature to estimate the snowmelt amount. If the air temperature is less than the base temperature, then the amount of melt is zero. Typically, the base temperature should be 0C.

The wet meltrate is used during time intervals when precipitation is falling as rain, and the rainfall rate is greater than the rain rate limit. It represents the rate at which the snowpack melts when it is raining on the snowpack.

The rain rate limit discriminates between dry melt and wet melt. The wet meltrate is applied as the meltrate when it is raining at rates greater than the rain rate limit. If the rain rate is less than the rain rate limit, the meltrate is computed as if there were no precipitation. The default value of 0mm/day is used if no value is entered, meaning that even a trace of precipitation results in the use of the wet melt rate.

A meltrate must be calculated for time intervals when the precipitation rate is less than the rain rate limit. The calculation starts with the meltrate antecedent temperature index. A coefficient is used to update the antecedent meltrate index from one time interval to the next. The default value of 0.98 is used if no value is entered.

An antecedent temperature index meltrate function is used to calculate a meltrate from the current meltrate index. The function must be specified separately in the *Paired Data Manager* before it can be used in the snow melt method. The function should define appropriate meltrates to use over the range of meltrate index values that will be encountered during a simulation. The melt rate for dry conditions typically ranges from 1 to 4 mm/degC-day.

Optionally, you may adjust the meltrate computed from the index meltrate function. A meltrate pattern may be specified that defines the percentage adjustment as a function of the time of year. If no meltrate pattern is selected, the meltrate will be computed only from the antecedent temperature index and the meltrate function. The pattern must be specified separately in the *Paired Data Manager* before it can be used in the snow melt method.

The cold limit accounts for the rapid changes in temperature that the snowpack undergoes during high precipitation rates. When the precipitation rate exceeds the specified cold limit, the antecedent cold content index is set to the temperature of the precipitation. If the temperature is above the base temperature, the cold content index is set to the base temperature. If the temperature is below the base temperature, the cold content index is set to the actual temperature. If

the precipitation rate is less than the cold limit, the cold content index is computed as an antecedent index. The default value of 0mm/day is used if no value is entered, meaning that even a trace of snowfall will reset the cold content.

The cold content antecedent temperature index coefficient is used to update the antecedent cold content index from one time interval to the next. This is a separate index from the one used to update the meltrate index. A default value of 0.5 is used if no value is entered.

An antecedent temperature index cold content function is used to calculate a cold content from the current cold content index. The function must be specified separately in the *Paired Data Manager* before it can be used in the snow melt method. The function should define appropriate cold contents to use over the range of cold content index values that will be encountered during a simulation. The cold rate typically ranges from 1.22 to 1.32 mm/degC-day.

The maximum liquid water capacity specifies the amount of melted water that must accumulate in the snowpack before liquid water becomes available at the soil surface for infiltration or runoff. Typically, the maximum liquid water held in the snowpack is on the order of 3%-5% of the snow water equivalent, although it can be higher. Liquid water can persist in the snow only if the snowpack temperature is at 0C; at which point the cold content is zero. The maximum is entered as a percentage of the snow water equivalent.

Heat from the ground can cause snowmelt, especially if the snowpack accumulates on ground that is only partially frozen or completely unfrozen. In these cases the warm ground is insulated by the snowpack. Heat from the warm ground will cause the bottom of the snowpack to melt. Two methods are available for specifying the melting of the snowpack due to contact with unfrozen ground. A fixed value can be entered; the same amount of melt is computed for the snowpack regardless of atmospheric conditions above the pack or the time of year. An annual pattern can alternately be entered; the pattern specifies the meltrate due to contact with the ground as a function of the time of year. The pattern must be entered in the *Paired Data Manager* before it can be used in the snowmelt method.

### ***Temperature Index***

The temperature index method is an extension of the degree-day approach to modeling a snowpack. A typical approach to the degree day is to have a fixed amount of snowmelt for each degree above freezing. This method includes a conceptual representation of the cold energy stored in the pack along with a limited memory of past conditions and other factors to compute the amount of melt for each



degree above freezing. As the snowpack internal conditions and atmospheric conditions change, the melt coefficient also changes.

The temperature index method includes a *Component Editor* with parameter data for all subbasins in the meteorologic model. A *Component Editor* is also included for each subbasin. Each subbasin must have at least one elevation band and may have up to ten elevation bands. A separate *Component Editor* is included for each elevation band. The *Watershed Explorer* provides access to the snowmelt component editors using a picture of a snowflake (Figure 264).

An air temperature gage must be selected in the atmospheric variables for each subbasin. The gage selected for air temperature must have an elevation defined in the time-series data manager.

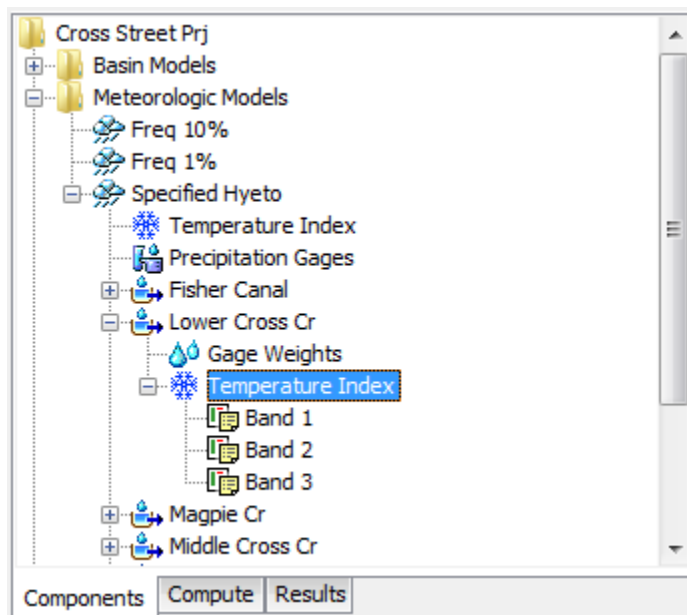

Figure 264. A meteorologic model using the temperature index snowmelt method with a component editor for all subbasins, a component editor for each individual subbasin, and a component for each elevation band.

A *Component Editor* for all subbasins in the meteorologic model includes most of the parameter data for the snowmelt method (Figure 265). The PX temperature is used to discriminate between precipitation falling as rain or snow. When the air temperature is less than the specified temperature, any precipitation is assumed to be snow. When the air temperature is above the specified temperature, any precipitation is assumed to be rain. This discrimination temperature may be up to 1C.

The difference between the base temperature and the air temperature defines the temperature index used in calculating snowmelt. The meltrate is multiplied by the difference between the air temperature and the base temperature to estimate the snowmelt amount. If the air temperature is less than the base temperature, then the amount of melt is zero. Typically, the base temperature should be 0C.



Temperature Index	
<b>Met Name: Specified Hyeto</b>	
*PX Temperature (C)	0.8
*Base Temperature (C)	0.0
*Wet Meltrate (MM/DEG C-DAY)	3.3
Rain Rate Limit (MM/DAY)	1.0
ATI-Meltrate Coefficient:	0.98
*ATI-Meltrate Function:	Default ati-melt 
Meltrate Pattern:	--None-- 
Cold Limit (MM/DAY)	1.2
ATI-Coldrate Coefficient:	0.84
ATI-Coldrate Function:	Default ati-cc 
Water Capacity (%)	3
Groundmelt Method:	Constant Value
Groundmelt (MM/DAY)	0

Figure 265. Temperature index snowmelt properties for all subbasins in a meteorologic model.

The wet meltrate is used during time intervals when precipitation is falling as rain, and the rainfall rate is greater than the rain rate limit. It represents the rate at which the snowpack melts when it is raining on the snowpack.

The rain rate limit discriminates between dry melt and wet melt. The wet meltrate is applied as the meltrate when it is raining at rates greater than the rain rate limit. If the rain rate is less than the rain rate limit, the meltrate is computed as if there were no precipitation. The default value of 0mm/day is used if no value is entered, meaning that even a trace of precipitation results in the use of the wet melt rate.

A meltrate must be calculated for time intervals when the precipitation rate is less than the rain rate limit. The calculation starts with the meltrate antecedent temperature index. A coefficient is used to update

the antecedent meltrate index from one time interval to the next. The default value of 0.98 is used if no value is entered.

An antecedent temperature index meltrate function is used to calculate a meltrate from the current meltrate index. The function must be specified separately in the *Paired Data Manager* before it can be used in the snow melt method. The function should define appropriate meltrates to use over the range of meltrate index values that will be encountered during a simulation. The melt rate for dry conditions typically ranges from 1 to 4 mm/degC-day.

Optionally, you may adjust the meltrate computed from the index meltrate function. A meltrate pattern may be specified that defines the percentage adjustment as a function of the time of year. If no meltrate pattern is selected, the meltrate will be computed only from the antecedent temperature index and the meltrate function. The pattern must be specified separately in the *Paired Data Manager* before it can be used in the snow melt method.

The cold limit accounts for the rapid changes in temperature that the snowpack undergoes during high precipitation rates. When the precipitation rate exceeds the specified cold limit, the antecedent cold content index is set to the temperature of the precipitation. If the temperature is above the base temperature, the cold content index is set to the base temperature. If the temperature is below the base temperature, the cold content index is set to the actual temperature. If the precipitation rate is less than the cold limit, the cold content index is computed as an antecedent index. The default value of 0mm/day is used if no value is entered, meaning that even a trace of snowfall will reset the cold content.

The cold content antecedent temperature index coefficient is used to update the antecedent cold content index from one time interval to the next. This is a separate index from the one used to update the meltrate index. A default value of 0.5 is used if no value is entered.

An antecedent temperature index cold content function is used to calculate a cold content from the current cold content index. The function must be specified separately in the *Paired Data Manager* before it can be used in the snow melt method. The function should define appropriate cold contents to use over the range of cold content index values that will be encountered during a simulation. The cold rate typically ranges from 1.22 to 1.32 mm/degC-day.

The maximum liquid water capacity specifies the amount of melted water that must accumulate in the snowpack before liquid water becomes available at the soil surface for infiltration or runoff. Typically, the maximum liquid water held in the snowpack is on the order of 3%-

5% of the snow water equivalent, although it can be higher. Liquid water can persist in the snow only if the snowpack temperature is at 0C; at which point the cold content is zero. The maximum is entered as a percentage of the snow water equivalent.

Heat from the ground can cause snowmelt, especially if the snowpack accumulates on ground that is only partially frozen or completely unfrozen. In these cases the warm ground is insulated by the snowpack. Heat from the warm ground will cause the bottom of the snowpack to melt. Two methods are available for specifying the melting of the snowpack due to contact with unfrozen ground. A fixed value can be entered; the same amount of melt is computed for the snowpack regardless of atmospheric conditions above the pack or the time of year. An annual pattern can alternately be entered; the pattern specifies the meltrate due to contact with the ground as a function of the time of year. The pattern must be entered in the *Paired Data Manager* before it can be used in the snowmelt method.

The *Component Editor* for each subbasin includes the parameter data necessary to calculate the air temperature for each elevation band (Figure 266). Each subbasin must have a specified lapse rate. The temperature for each elevation band is computed using the temperature recorded in the time-series gage, the elevation of the time-series gage, the lapse rate for the subbasin, and the elevation of the elevation band. The adjusted temperature for each elevation band is computed by adding a correction to the specified temperature gage, computed as the lapse rate multiplied by the difference between the band elevation and the gage elevation. The lapse rate should be negative if the air temperature is cooler at high elevation than at low elevation.

Temperature Index	
<b>Met Name: Specified Hyeto</b>	
<b>Element Name: Lower Cross Cr</b>	
*Lapse Rate (DEG C/1000 M)	-5.1
Index (MM)	

Figure 266. Entering temperature index snowmelt properties for a subbasin.

An optional precipitation index may be used. In order to use the index, it must be specified for the subbasin as a whole and also for each elevation band. The ratio of the index for the subbasin and the index at an elevation band is used to adjust the precipitation for each elevation band. Indexing is one method to adjust for orographic trends in precipitation.

Each subbasin is broken into one or more elevation bands; each band has its own parameter data. One elevation band may be used to represent a subbasin with very little terrain variation. Subbasins with large elevation variations should use multiple elevation bands. Create an elevation band by clicking with the right mouse button on the snowmelt icon under a subbasin (Figure 267). A context menu is displayed that allows you to create a new elevation band. You can also create an elevation band by clicking with the right mouse button on any existing elevation band. The same context menu is displayed that allows you to create a new elevation band. Delete an elevation band by clicking on it with the right mouse button. A context menu is displayed that allows you to delete the elevation band. Clicking on the elevation band icon will access the *Component Editor* used for each band (Figure 268).

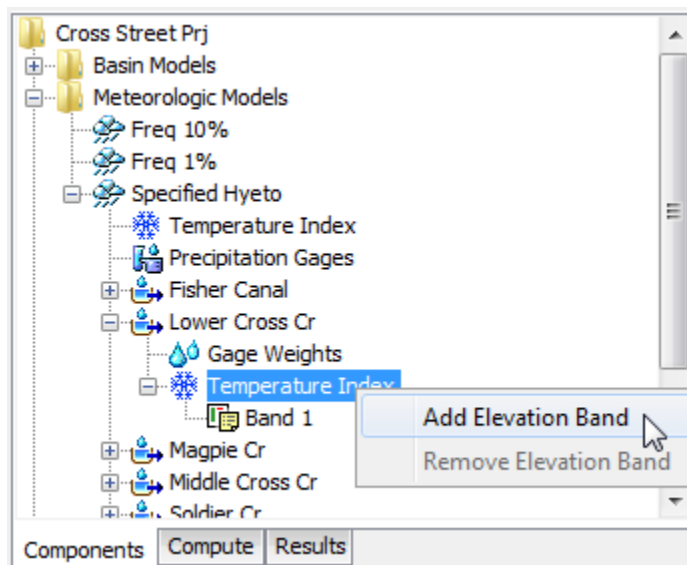

Figure 267. Adding a temperature index elevation band to a subbasin.

Temperature Index		Band 2
<b>Met Name: Specified Hyeto</b>		
<b>Element Name: Lower Cross Cr</b>		
<b>Band Name: Band 2</b>		
*Percent (%)	38	
*Elevation (M)	800	
Index (MM)		
*Initial SWE (MM)	125	
*Initial Cold Content (MM)	0	
*Initial Liquid Water (MM)	2	
*Initial Cold Content ATI (C)	0	
*Initial Melt ATI (DEGC-DAY)	0	

Figure 268. Specifying properties for a temperature index elevation band.

A *Component Editor* is provided for each elevation band where parameter data defines the relative size of the band, the elevation of the band, and initial conditions for snowpack in the band. You must specify the percentage of the subbasin that each elevation band composes. An elevation band is not required to be contiguous. The percentage specified for each elevation band will automatically be normalized if the sum of the percentages across all subbasins does not equal 100. There is no limit to the number of elevation bands that can be used, but at least one is required. Typically only one band is used in watersheds with small elevation differences. Mountainous watersheds usually require several bands for each subbasin.

Enter the average elevation for each elevation band. Typically the specified elevation will be either the area-weighted elevation of the band, or the average of the highest and lowest points in the band.

The optional precipitation index must be entered in combination with an index value for the subbasin as a whole if you wish to adjust precipitation for each elevation band. In general, precipitation increases at higher elevations in mountaneous watersheds.

The initial snow water equivalent (SWE) that exists at the beginning of the simulation must be entered. This information is usually determined by interpolating from actual measurements of snow water equivalent. This value can be set to zero if there is no snow.

The initial cold content that exists at the beginning of the simulation must be entered. It represents the heat required to raise the temperature of the snow pack to 0C (32F) and is expressed as a number equivalent to mm (inches) of frozen water. If there is no snow at the beginning of the simulation, it can be set to zero. If there is a

snowpack, it can be estimated as the depth of snow multiplied by the snow density multiplied by the heat capacity of snow multiplied by the number of degrees below the freezing point.

The liquid water held within the snowpack at the beginning of the simulation must be entered. Liquid water can persist in the snow only if the snowpack temperature is at 0C (32F). There are few conditions when this value can be exactly known. One case is when there is no snowpack and it can be set to zero. A second case is when the air temperature has been continually below freezing for several days and it can be set to zero.

The initial cold content antecedent temperature index is an index to the snow temperature near the surface of the snowpack. It should be set to the approximate snowpack temperature at the beginning of the simulation. If the initial temperature is not known, it can be set to 0C (32F).

The seasonal variation of meltrate is indexed by an antecedent temperature function. The initial meltrate ATI should be thought of as similar to "the accumulated thawing degree days." This antecedent temperature function allows the melt rate to change as the snowpack matures and ages. If there is no snow on the ground at the start of the simulation this term can be set to zero. It can also be set to zero if the simulation is starting during or at the end of a cold period when air temperatures were continually below the base temperature. Otherwise it must be calculated as the accumulation of degree-days since the last period of sustained air temperature below freezing.

## References

Allen, R.G., L.S. Pereira, D. Raes, and M. Smith. 1998. "Crop Evapotranspiration: Guidelines for Computing Crop Water Requirements." FAO Irrigation and Drainage Paper No. 56, Rome, Italy.

Bristow, K.L. and G.S. Campbell. 1984. "On the Relationship Between Incoming Solar Radiation and Daily Maximum and Minimum Temperature." *Agricultural and Forest Meteorology*, vol 31, pp 159-166.

Engineering Manual 1110-2-1411. March 1065. Standard Project Flood Determination. U.S. Army Corps of Engineers, Davis, CA.

FAO Irrigation and Drainage Paper 56. 1998. Crop Evapotranspiration: Guidelines for Computing Crop Water Requirements. Food and Agriculture Organization, Rome.

Hansen, E.M., L.C. Schreiner, and J.F. Miller. 1982. Application of Probable Maximum Precipitation Estimates – United States East of the 105<sup>th</sup> Meridian. Hydrometeorological Report No. 52. National Weather Service, Washington, D.C.

Priestley, C.H.B. and R.J. Taylor. 1972. "On the Assessment of Surface Heat Flux and Evaporation Using Large-Scale Parameters." *Monthly Weather Review*, vol 100, pp81-92.

Satterlund, D.R. 1979. "An Improved Equation for Estimating Long-Wave Radiation from the Atmosphere." *Water Resources Research*, vol 15, no 6, pp 1649-1650.

Schreiner, L.C. and J.T. Riedel. 1978. Probable Maximum Precipitation Estimates, United States East of the 105<sup>th</sup> Meridian. Hydrometeorological Report No. 51. National Weather Service, Washington, D.C.

World Meteorological Organization. 2008. "8. Measurement of Sunshine Duration." *Guide to Meteorological Instruments and Methods of Observations*, Geneva, Switzerland.



## CHAPTER 12

# Hydrologic Simulation

This chapter describes how watershed and meteorology information is combined to simulate the hydrologic response. The simulation run is the primary mode for performing simulations. In effect the simulation run applies the meteorology conditions to the watershed land surface to determine the runoff. In addition to configuring and computing simulation runs, this chapter also describes how to access the computed results.

### Simulation Runs

Simulation runs are the primary method of computing results. Each run is composed of one meteorologic model, one basin model, and one control specifications. Results can be visualized as graphs, summary tables, and time-series tables either through the basin map or from the *Watershed Explorer*. In addition to selecting the meteorologic, basin, and control components, advanced features for controlling the run are also included.

#### Creating a New Run

A new simulation run is created using a wizard that helps you navigate the steps to creating a new run. There are two ways to access the wizard. The first way to access the wizard is to click on the **Compute** menu and select the **Create Compute ⇒ Simulation Run** command; it is only enabled if at least one basin model, one meteorologic model, and one control specifications exist. The wizard will open and begin the process of creating a new simulation run. The second way to access the wizard is from the *Simulation Run Manager*. Click on the **Compute** menu and select the **Simulation Run Manager** command. The *Simulation Run Manager* will open and show any runs that already exist. Press the **New...** button to access the wizard and begin the process of creating a simulation run, as shown in Figure 269.

The first step of creating a simulation run is to provide the name for the new run (Figure 270). A default name is provided for the new simulation run; you can use the default or replace it with your own choice. After you finish creating the run you can add a description to it. If you change your mind and do not want to create a new simulation run, you can press the **Cancel** button at the bottom of the wizard or the **X** button in the upper right corner of the wizard. The **Cancel** button can be pressed at any time you are using the wizard. Press the **Next>**

button when you are satisfied with the name you have entered and are ready to proceed to the next step.

The second step of creating a simulation run is to select a basin model. All of the basin models in the project are shown and you must select one before proceeding to the next step. By default the first basin model in the table is selected. The selected model is highlighted. You can use your mouse to select a different basin model by clicking on it in the table of available choices. You can also use the arrow keys on your keyboard to select a different model. Press the **Next>** button when you are satisfied with the basin model you have selected and are ready to proceed to the next step. Press the **<Back** button if you wish to return to the previous step and change the name for the new simulation run.

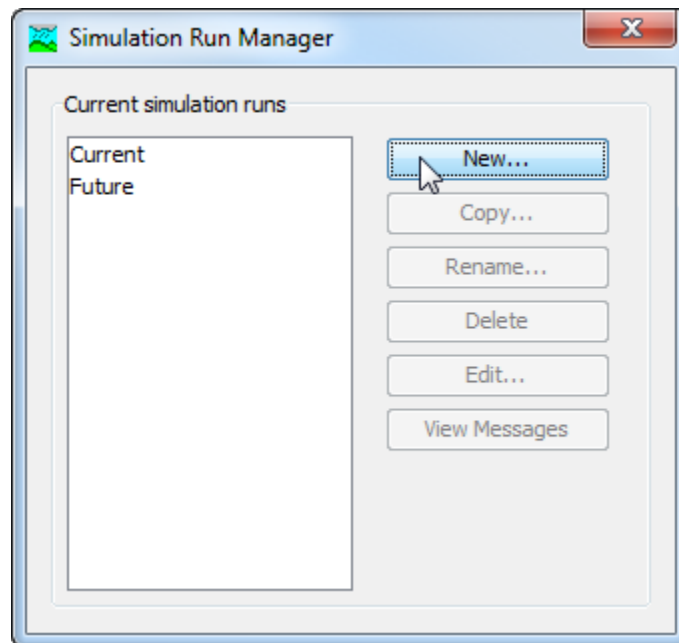

*Figure 269. Beginning the process of creating a new simulation run using the Simulation Run Manager.*

The third step of creating a simulation run is to select a meteorologic model. All of the meteorologic models in the project are shown and you must select one before proceeding to the next step. By default the first meteorologic model in the table is selected. The selected model is highlighted. You can use your mouse to select a different meteorologic model by clicking on it in the table of available choices. You can also use the arrow keys on your keyboard to select a different model. Press the **Next>** button when you are satisfied with the meteorologic model you have selected and are ready to proceed to the next step. Press the **<Back** button if you wish to return to the previous step and select a different basin model.

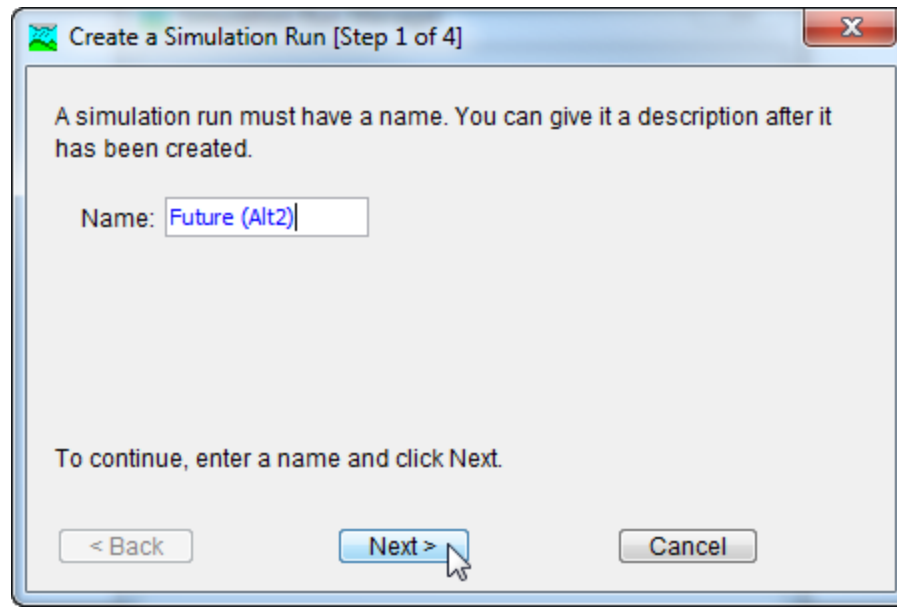

Figure 270. Entering a name for a new simulation run. The remaining steps are to select a basin model, meteorologic model, and control specifications.

The fourth and final step of creating a simulation run is to select a control specifications. All of the control specifications in the project are shown and you must select one before proceeding to the next step. By default the first control specifications in the table is selected. The selected specifications is highlighted. You can use your mouse to select a different control specifications by clicking on it in the table of available choices. You can also use the arrow keys on your keyboard to select a different specifications. Press the **Finish** button when you are satisfied with the name you have entered and the components you have selected, and are ready to create the simulation run. Press the **<Back** button if you wish to return to the previous step and select a different meteorologic model.

### ***Copying a Run***

There are two ways to copy a simulation run. Both methods for copying a run create an exact duplicate with a different name. Once the copy has been made it is independent of the original and they do not interact.

The first way to create a copy is to use the *Simulation Run Manager*, which is accessed from the **Compute** menu. Select the simulation run you wish to copy by clicking on it in the list of available simulation runs. The selected run is highlighted after you select it. After you select a run you can press the **Copy...** button on the right side of the window. A new *Copy Simulation Run* window (Figure 271) will open where you can name and describe the copy that will be created. A default name

is provided for the copy; you can use the default or replace it with your own choice. A description can also be entered; if it is long you can use the button to the right of the description field to open an editor. When you are satisfied with the name and description, press the **Copy** button to finish the process of copying the selected simulation run. You cannot press the **Copy** button if no name is specified. If you change your mind and do not want to copy the selected simulation run, press the **Cancel** button or the **X** button in the upper right to return to the *Simulation Run Manager* window.

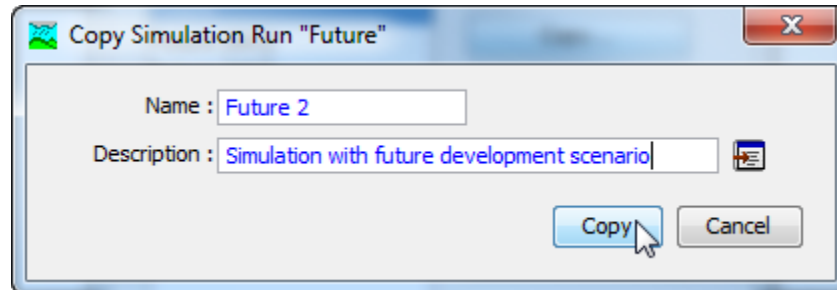

Figure 271. Creating a copy of a simulation run.

The second way to copy is from the "Compute" tab of the *Watershed Explorer*. Move the mouse over the simulation run you wish to copy, then press the right mouse button (Figure 272). A context menu is displayed that contains several choices including copy. Click the **Create Copy...** command. A new *Copy Simulation Run* window will open where you can name and describe the copy that will be created. A default name is provided for the copy; you can use the default or replace it with your own choice. A description can also be entered; if it is long you can use the button to the right of the description field to open an editor. When you are satisfied with the name and description, press the **Copy** button to finish the process of copying the selected simulation run. You cannot press the **Copy** button if no name is specified. If you change your mind and do not want to copy the selected simulation run, press the **Cancel** button or the **X** button in the upper right of the *Copy Simulation Run* window to return to the *Watershed Explorer*.

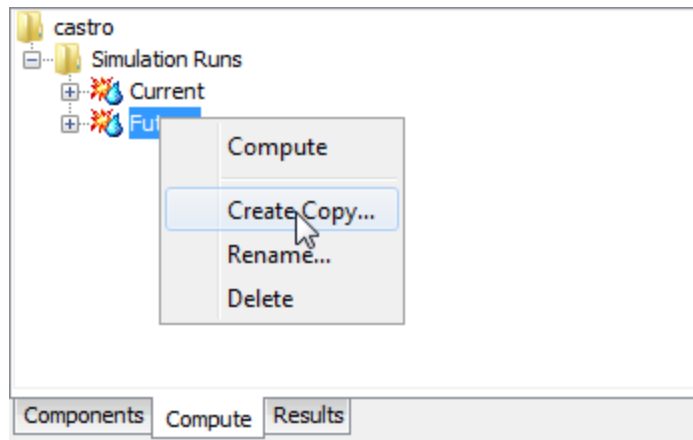

Figure 272. Copying a simulation run from the Watershed Explorer. The Copy Simulation Run window will appear after the **Create Copy...** menu command is selected.

### ***Renaming a Run***

There are two ways to rename a simulation run. Both methods for renaming a run change its name and then all references to the old run name are automatically updated to the new name.

The first way to perform a rename is to use the *Simulation Run Manager*, which you can access from the **Compute** menu. Select the simulation run you wish to rename by clicking on it in the list of available simulation runs. The selected run is highlighted after you select it. After you select a run you can press the **Rename...** button on the right side of the window. A new *Rename Simulation Run* window (Figure 273) will open where you can provide the new name. If you wish you can also change the description at the same time. If the new description will be long, you can use the button to the right of the description field to open an editor. When you are satisfied with the name and description, press the **Rename** button to finish the process of renaming the selected simulation run. You cannot press the **Rename** button if no name is specified. If you change your mind and do not want to rename the selected simulation run, press the **Cancel** button or the **X** button in the upper right of the *Rename Simulation Run* window to return to the *Simulation Run Manager* window.

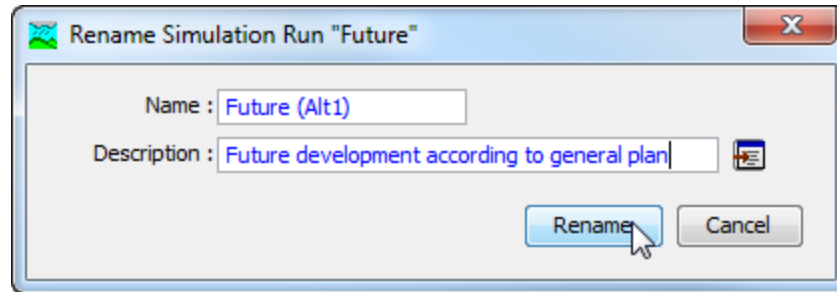

Figure 273. Renaming a simulation run. This was accessed from the Simulation Run Manager.

The second way to rename is from the "Compute" tab of the *Watershed Explorer*. Select the simulation run you wish to rename by clicking on it in the *Watershed Explorer*; it will become highlighted. Keep the mouse over the selected run and click the left mouse button again. The highlighted name will change to editing mode (Figure 274). You can then move the cursor with the arrow keys on the keyboard or by clicking with the mouse. You can also use the mouse to select some or all of the name. Change the name by typing with the keyboard. When you have finished changing the name, press the **Enter** key to finalize your choice. You can also finalize your choice by clicking elsewhere on the "Compute" tab. If you change your mind while in editing mode and do not want to rename the selected simulation run, press the **Escape** key.

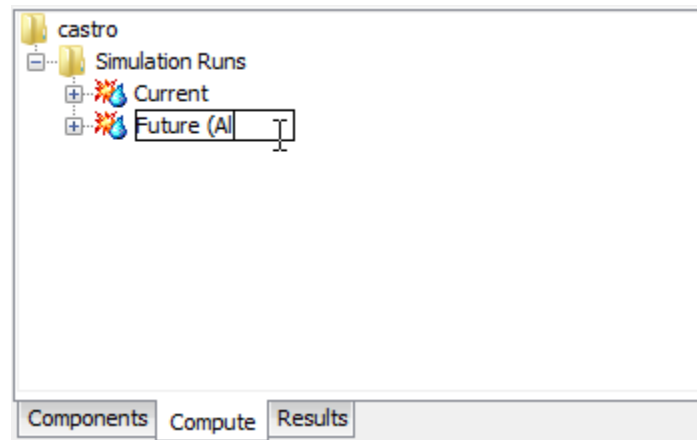

Figure 274. Renaming a simulation run in the Watershed Explorer.

### Deleting a Run

There are two ways to delete a simulation run. Both methods for deleting a run remove it from the project, automatically update all references to that run, and delete previously computed results. Once a run has been deleted it cannot be retrieved or undeleted. Any references to the deleted run will switch to using no simulation run, which is usually not a valid choice during a simulation. At a later time

you will have to go to those components and manually select a different simulation run.

The first way to perform a deletion is to use the *Simulation Run Manager*, which you can access from the **Compute** menu. Select the simulation run you wish to delete by clicking on it in the list of available simulation runs. The selected run is highlighted after you select it. After you select a run you can press the **Delete** button on the right side of the window. A window will open where you must confirm that you wish to delete the selected run as shown in Figure 275. Press the **OK** button to delete the run. If you change your mind and do not want to delete the selected simulation run, press the **Cancel** button or the **X** button in the upper right to return to the *Simulation Run Manager* window.

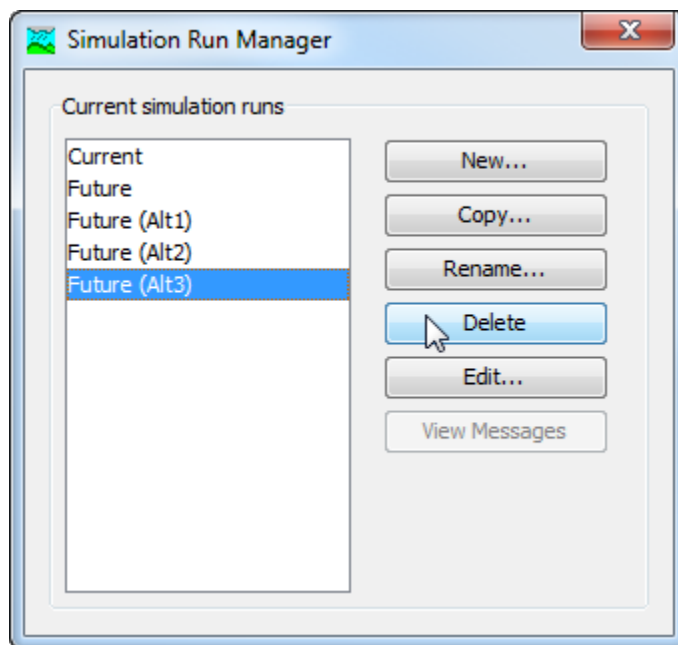

Figure 275. Preparing to delete a simulation run from the *Simulation Run Manager*. A confirmation will be required after pressing the **Delete** button.

The second way to delete is from the "Compute" tab of the *Watershed Explorer*. Move the mouse over the simulation run you wish to delete and press the right mouse button (Figure 276). A context menu is displayed that contains several choices including delete. Click the **Delete** command. A window will open where you must confirm that you wish to delete the selected run. Press the **OK** button to delete the run. If you change your mind and do not want to delete the selected simulation run, press the **Cancel** button or the **X** button in the upper right to return to the *Watershed Explorer*.

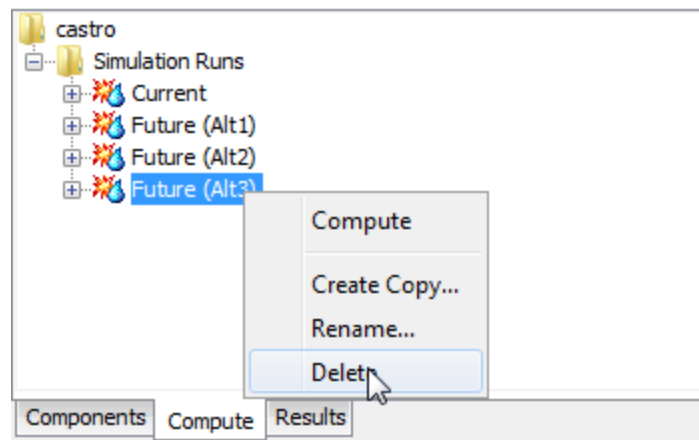

Figure 276. Deleting a simulation run in the Watershed Explorer.

### Importing a Run

A simulation run can be imported into the current project. The run to be imported is selected from a source project. Once you select the run to be imported, all of the necessary simulation components will be imported into the current project. This includes the basin model, meteorologic model, control specifications, and any supporting data. The supporting data include background maps and grid cell file for the basin model, and shared data such as time-series gages, paired data, and grid data used either in the basin or meteorologic model. A simulation run will be created in the current project using the components that have been imported.

To import a simulation run, begin by selecting the **File⇒Import⇒Simulation Run** menu command. Use the file chooser to select the project file for the project that contains the simulation run you wish to import (Figure 277). You will then be provided a selection list of available simulation runs in that source project (Figure 278). Select the simulation run that you wish to import and press the **Import** button.



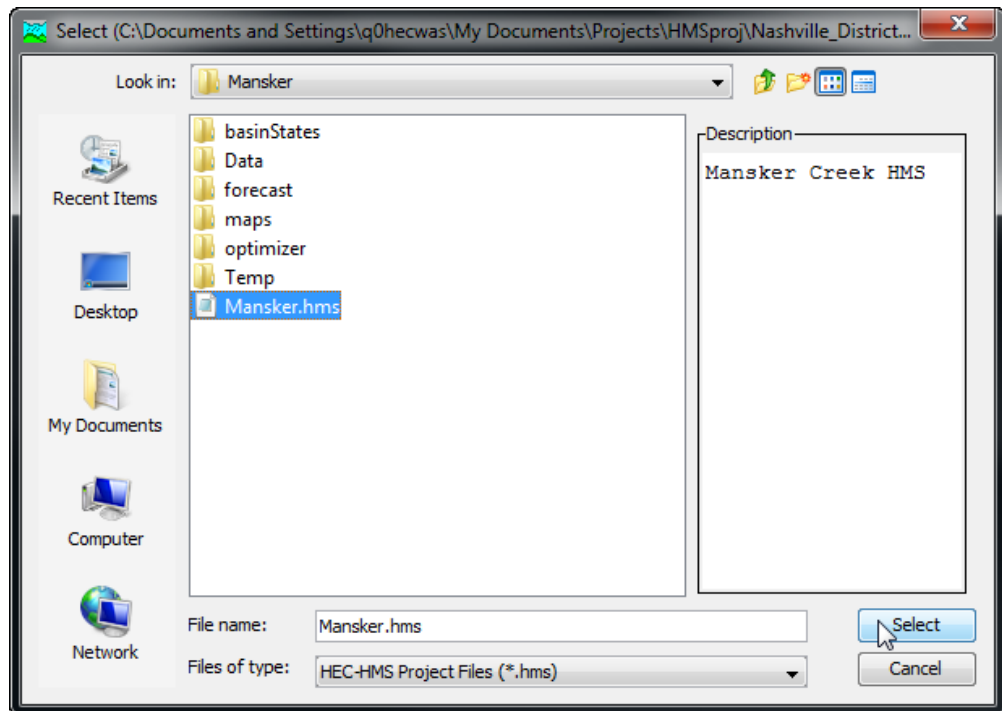

Figure 277. Selecting the source project to import a simulation run.

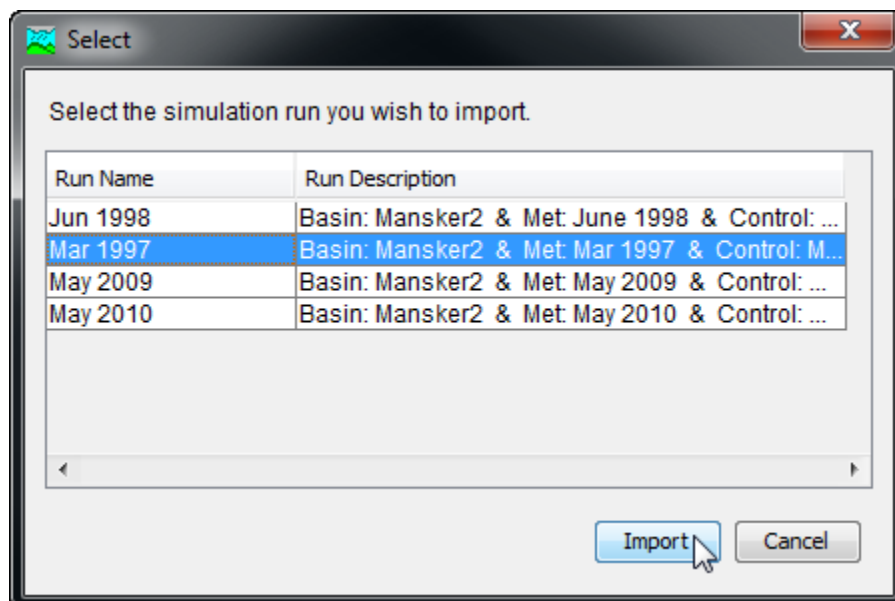

Figure 278. Selecting the simulation run to be imported from the source project into the current project.

Depending on the data used in the basin model and meteorologic model, you may be prompted to choose how to treat time-series, paired, and gridded data. If you select to import the data, a copy of the data will be made in the current project directory and appropriate gage, paired data, and grid components will be automatically created. Any references in the basin model or meteorologic model to the time-

series, paired, and gridded data will be automatically updated to use the new shared component data in the current project. If you choose not to import the data, the basin model and meteorologic model will be imported without any of the data. In this second case, the current project should already include the necessary time-series, paired, and gridded data necessary for the proper simulation of the basin model and meteorologic model.

Depending on the data used in the basin model and meteorologic model, you may be prompted to choose how to treat external data. If you choose to localize external data, then copies of the files will be made in the current project directory. Any references in the basin model or meteorologic model to external data will be automatically updated to use the new copies in the current project. If you choose not to localize the external data, the components in the current project will be updated to reference the files in their original locations.

### **Selecting Components**

The principal task when creating a simulation run using the wizard is the selection of a basin model, meteorologic model, and control specifications. However, you can change the components you wish to use at any time using the *Component Editor* for a simulation run. Access the *Component Editor* from the "Compute" tab of the *Watershed Explorer*. If necessary, click on the "Simulation Runs" folder to expand it and view the available simulation runs. Click on the simulation run node you wish to edit and its *Component Editor* will automatically be shown (Figure 279). The *Component Editor* contains three lists for selecting the basin model, meteorologic model, and control specifications, respectively. The first selection list shows all of the basin models currently available in the project. Likewise, the second list contains all of the meteorologic models and the third list contains all of the control specifications. As the user, you are responsible for knowing which components are intended to be used together to produce simulation results.

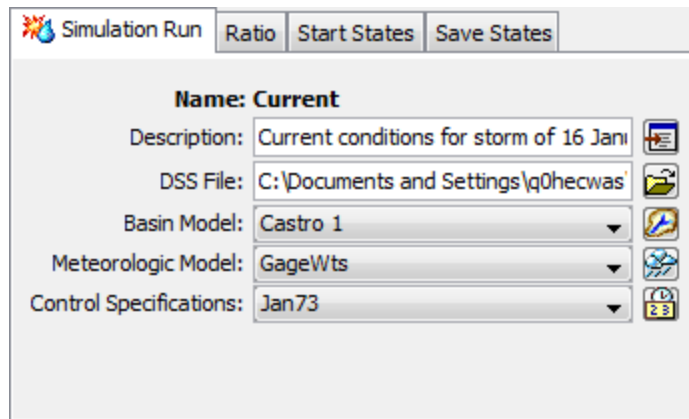

Figure 279. The simulation run component editor can be used to change a selected component after the run has been created.

## Simulation Results Output

All of the model components produce time-series results during the simulation process. Some components also produce grid results. By default, all of these results are stored in the project DSS file. The output DSS file can be changed for each simulation run. To change the output file, specify a new file in the *Component Editor* (Figure 279).

## Precipitation and Flow Ratios

Using precipitation and flow ratios is optional for a simulation run. If you do not use ratios, the simulation results will be exactly determined by the meteorologic conditions specified in the meteorology model and the watershed physical properties specified in the basin model. Optionally, you can apply a ratio to the precipitation computed by the meteorologic model before the precipitation is applied to the basin model. Alternately, you may instead apply a ratio to the outflow computed by subbasin and source elements in the basin model before routing the outflow downstream through the element network. You must choose between applying no ratio, a precipitation ratio, or a flow ratio. The same ratio is applied to all elements.

The ratio for the simulation run is accessed from the "Compute" tab of the *Watershed Explorer*. Click on the "Ratio" node under the simulation run to display the *Component Editor* for the ratio (Figure 280). The "Ratio" and other optional tabs are always shown whenever the *Component Editor* is shown. Select the type of ratio you wish to apply from the available choices. If you select the precipitation method, you can only choose to apply the ratio to subbasins. If you select the flow method, you can choose to apply the ratio to subbasins, sources, or both element types. Finally, enter the ratio value. When working with a precipitation ratio, the precipitation value for each time step computed by the meteorologic model is multiplied by the specified

ratio before the precipitation is applied to the subbasin elements. When working with a flow ratio, the outflow computed for each time step by the basin model is multiplied by the specified ratio before the outflow is routed to the next downstream element. You can only select whether to apply a ratio to subbasins and sources, and enter a ratio, if a ratio method is actually selected.

The screenshot shows a software interface with four tabs: 'Simulation Run', 'Ratio', 'Start States', and 'Save States'. The 'Ratio' tab is selected. Below the tabs, the following settings are displayed:

- Name:** Current
- Ratio Method:** Precipitation (dropdown menu)
- Apply to Subbasins:** Yes (dropdown menu)
- Apply to Sources:** No (dropdown menu)
- Ratio:** 1.25 (text input field)

*Figure 280. Entering a precipitation ratio for all of the subbasins in the simulation run. If a flow ratio were selected, it could be applied to subbasins or sources or both subbasins and sources.*

### **Start and Saved States**

The various mathematical equations used in the basin and meteorologic models all contain state variables. A state variable is simply the current condition of the system at the end of a time interval. For example, the state variable in a reservoir is the amount of water in storage, usually measured as an elevation. In the soil moisture accounting loss method, the state variable is the amount of water currently held in each of the layers. The state variables change during a simulation in response to changing boundary conditions and the dynamics of the mathematical equation governing the method.

The state variables all must be specified at the beginning of a simulation, in which case they are called initial conditions. Some methods allow you to specify the value you wish to use, such as the initial storage in a reservoir. Some methods implicitly specify the initial condition, for example loss methods that allow you to specify the amount of infiltration that must occur before surface runoff begins, often called the initial loss. Many of the channel routing methods assume the initial condition that initial outflow equals the first inflow to the reach.

States have two main purposes: breaking long simulations into smaller time periods, and real-time forecasting operations. In the first case of long simulations, using states achieves exactly the same results as

one long simulation. Suppose that a long simulation covers all of 1995 and 1996. You could configure a simulation run for 1995 and save states at the end of the simulation. You could then configure a simulation for 1996 that uses as start states the states saved at the end of the 1995 run. The results obtained by breaking the simulation into two runs and using states would be identical to the results obtained from a single long run. This approach can be useful when performing continuous simulation for many years or decades. In the second case of real-time forecasting operations, the typical approach is often to compute a simulation run daily and forecast three to five days into the future. The simulation can be configured to run for five days, saving the state variables at the end of the first day. When the forecast is updated on the subsequent day, it can start from the saved states of the previous day and continue forward. In this way, continuously updated results can be obtained without requiring the simulation to start at the last known watershed conditions which might be very old.

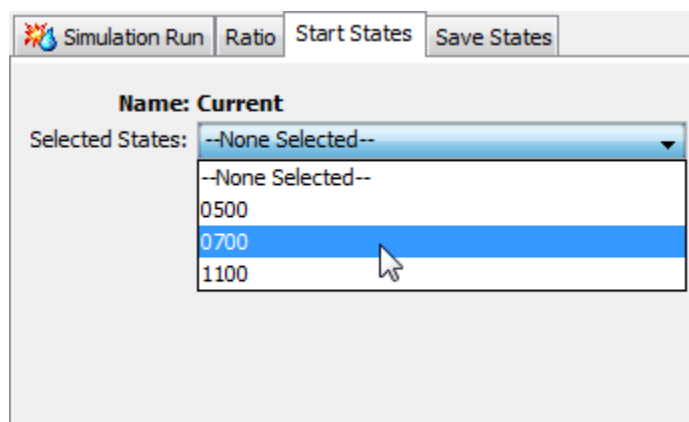

Figure 281. Selecting a start states for a simulation run.

Saving out the start variable during a simulation run, or starting a run from saved state variables is optional. If you do not use start states, then the initial conditions will be specified from the basin and meteorologic models. If you do use the start states, the initial conditions specified in the basin and meteorologic models will be overridden by the values contained in the saved states used as the start states. If you do not use save states, the simulation will run normally. If you do choose to save states, the simulation will pause momentarily to save the state variables and then continue normally. When start states are used, they must have been saved at exactly the same time as the start time in the selected control specifications.

Selecting optional start states for the simulation run is accessed from the "Compute" tab of the *Watershed Explorer*. Click on the "Start States" node under the simulation run to display the *Component Editor* for the start states (Figure 281). The "Start States" and other optional

tabs are always shown whenever the *Component Editor* is shown. You can choose the states you wish to use from the selection list. Only states saved by a different simulation run using the same basin model are shown. The only way to create states for use as saved states is by allowing the program to save them during a separate simulation run. You will not be able to select start states unless there are valid states available.

Selecting optional save states for the simulation run is accessed from the "Compute" tab of the *Watershed Explorer*. Click on the "Save States" node under the simulation run to display the *Component Editor* for save states (Figure 282). The "Save States" and other optional tabs are always shown whenever the *Component Editor* is shown. You must specify a name for the save states and optionally may enter a description. There are two ways to specify when the states will be saved: at the end of the simulation run, or at a specified time during the simulation run. If you select to save states at the end of the run, the program will automatically determine the correct date and time to save states. If you select to save states at a specific time, you must enter the date and time. The specified date and time must be after the start and either at or before the end of the simulation run.

The screenshot shows a software interface with four tabs: "Simulation Run", "Ratio", "Start States", and "Save States". The "Save States" tab is selected. Below the tabs, the text "Name: Current" is displayed. There are five input fields: "States Name" with the value "End", "Description" with the value "Current at simulation end", "End of Run" with a dropdown menu set to "Yes", "Date (ddMMMYYYY)" which is empty, and "Time (HH:mm)" which is empty. A small icon of a document with a plus sign is located to the right of the description field.

Figure 282. Configuring a simulation run to save states at the end of the compute time window.

## Computing Results for a Run

Results for a simulation run are generated by computing it. Changes in all the components used in the run are automatically tracked to determine if the results are current. When the results are no longer current, the run must be recomputed in order to refresh the results. Computing results begins with selecting a simulation run.

## Selecting a Current Simulation Run

There are two ways to select the current simulation run. Both methods set the run so that it can be computed and results can be accessed from the *Watershed Explorer* and the basin map as soon as they are available. The current simulation run is shown in the title of the basin map.

The first way to select the current simulation run is from the toolbar. The compute selection box shows all of the compute components in the project; simulation runs appear first in the selection box. Each simulation run in the selection box includes the prefix `Run` followed by the name of the simulation run. Click on the toolbar selection box and choose a simulation run to become the current run.

The second way to select the current simulation run is from the *Watershed Explorer*, on the "Compute" tab. Select the simulation run you wish to become the current run by clicking on it in the *Watershed Explorer*. The simulation runs are listed alphabetically in the "Simulation Runs" folder.

## Computing a Simulation Run

There are three ways to compute the currently selected simulation run. All methods automatically perform parameter checking, and if no errors are generated, proceed to the actual computing of simulation results. Additionally, the program is designed to be computationally efficient. Only components with data changes since the last compute will be recomputed; the remainder of the components have not changed so previous simulation results are still applicable. If you wish, you may force all components to be recomputed regardless of data changes since the last compute using a choice in the [program settings](#).

The first way to compute a simulation run is from the **Compute** menu. Click on the **Compute** menu and then select the **Compute Run** command. The name of the current simulation run is shown in brackets as part of the menu command. If the command is not available, it is because there is no current simulation run; you must first select a run. A window will automatically open that shows the progress of the compute. You will need to manually close the window when the compute is done, whether it failed or was successful. If you wish to force all components to be recomputed instead of just those with data changes, hold the *control* key while selecting the menu command.

The second way to compute a simulation run is from the *Watershed Explorer*, on the "Compute" tab. Select the simulation run you wish to compute by clicking on it in the *Watershed Explorer* with the right mouse button. A context menu is displayed that contains several

choices including compute. Click the **Compute** command. The progress window will automatically open. If you wish to force all components to be recomputed instead of just those with data changes, hold the *control* key while selecting the right mouse menu command.

The third way to compute a simulation run is from the toolbar. The compute button is enabled whenever there is a current run that can be computed. If the button is not available or shows a different type of compute, you must first select a simulation run. Press the button to compute the current simulation run. The progress window will automatically open. If you wish to force all components to be recomputed instead of just those with data changes, hold the *control* key while selecting the toolbar button.

### ***Computing to a Computation Point***

Any hydrologic element in a basin model can be designated as a computation point. Selecting a computation point and unselecting a point is described in [Chapter 6](#). It is also possible to compute a simulation run to a computation point. This method of computing results only computes the hydrologic element designated as a computation point. Any hydrologic elements upstream of the computation point are also computed with it. This approach to computing results can save time by not performing any calculations downstream of the computation point.

A simulation run can be computed to a point from the *Basin Model Map* window whenever a run is selected. Right-click on a computation point in the map and select the **Compute To Point** command (Figure 283). The command can only be selected when there is a current simulation run and the element has been designated as a computation point.



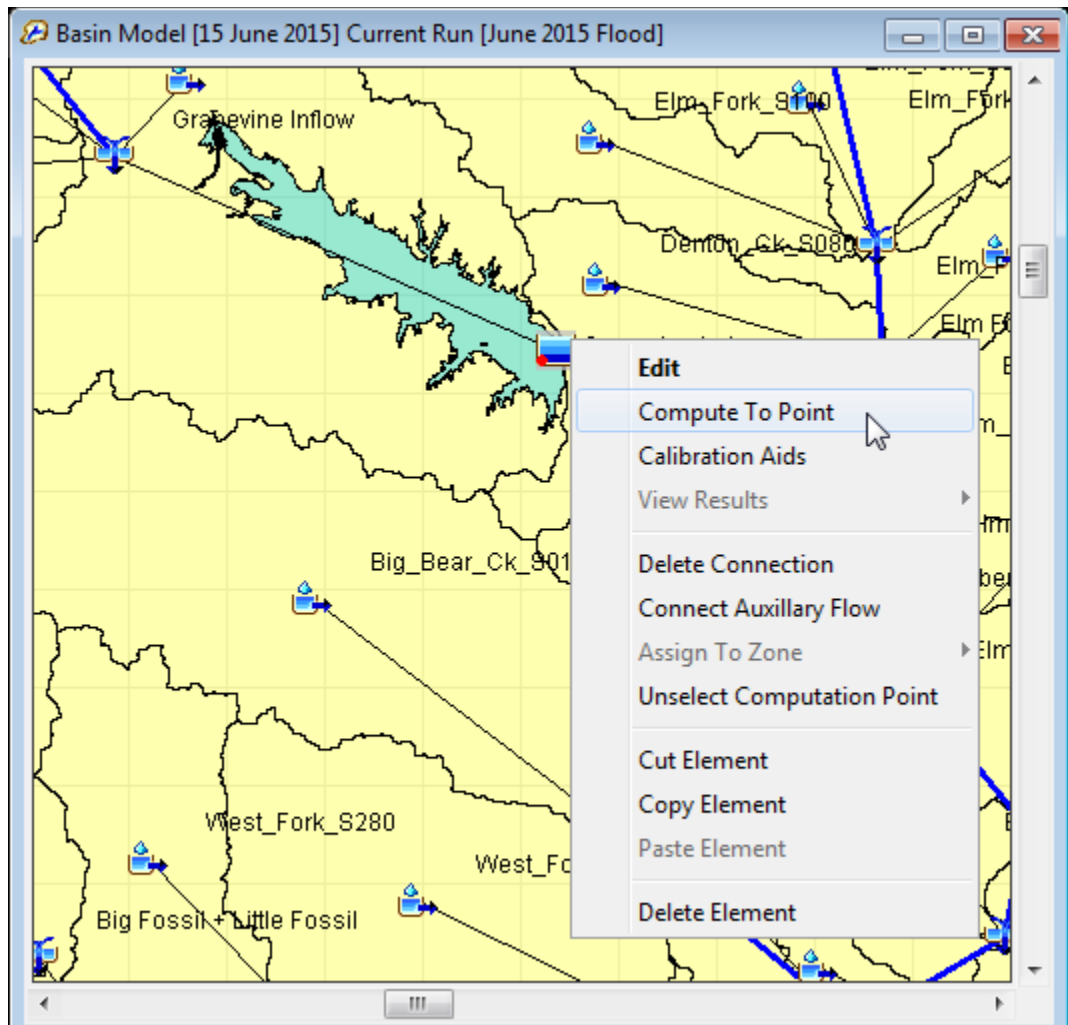

Figure 283. Computing simulation run results to an element that has been designated a computation point.

### Using Calibration Aids at a Computation Point

Calibration aids include the custom editor and the custom results configured at a computation point. Configuring a custom editor and results at a computation point is described in [Chapter 6](#). Once the customizable editor and result graphs have been configured, the aids can be used from the *Basin Model Map* window whenever a simulation run is selected. Right-click on a computation point in the map and select the **Calibration Aids** command (Figure 284). The command can only be selected when there is a current simulation run. Selecting the command will open the customizable editor and the customized result graphs. An example custom editor is shown in Figure 285.

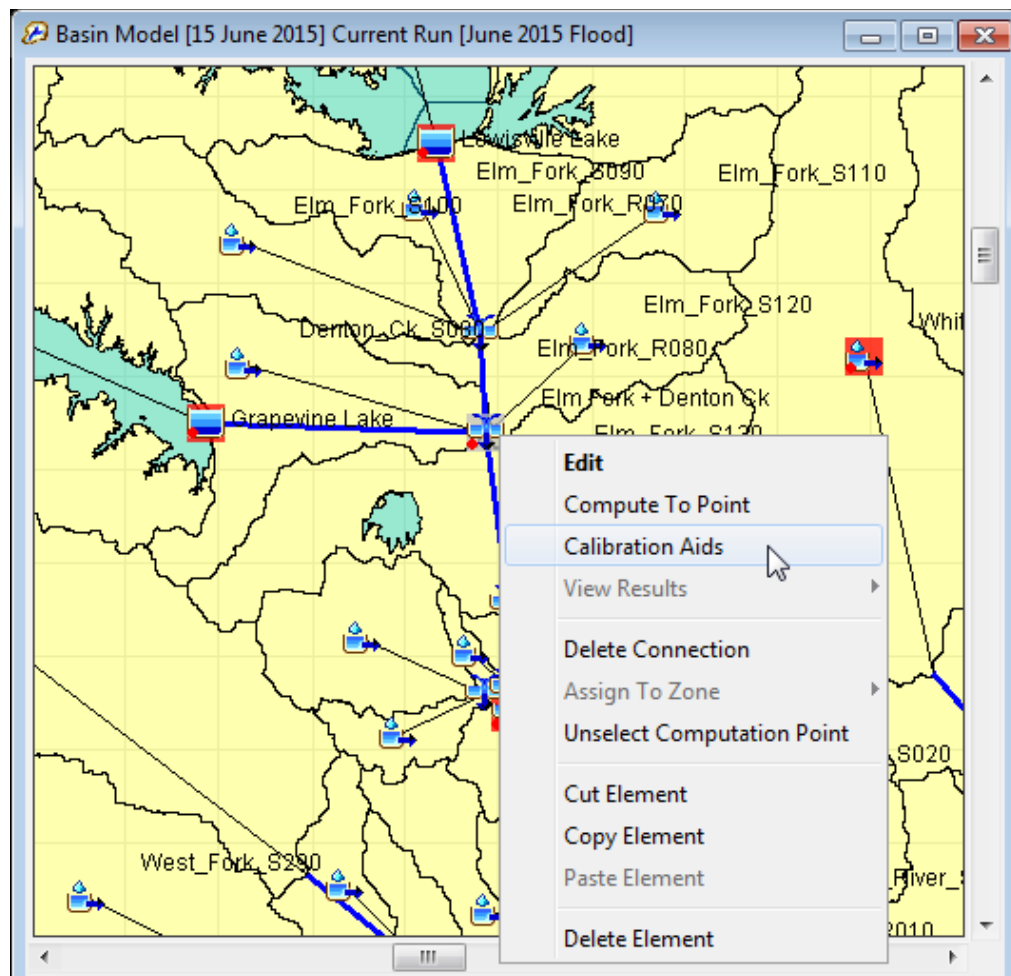

Figure 284. Opening the calibration aids at a computation point.

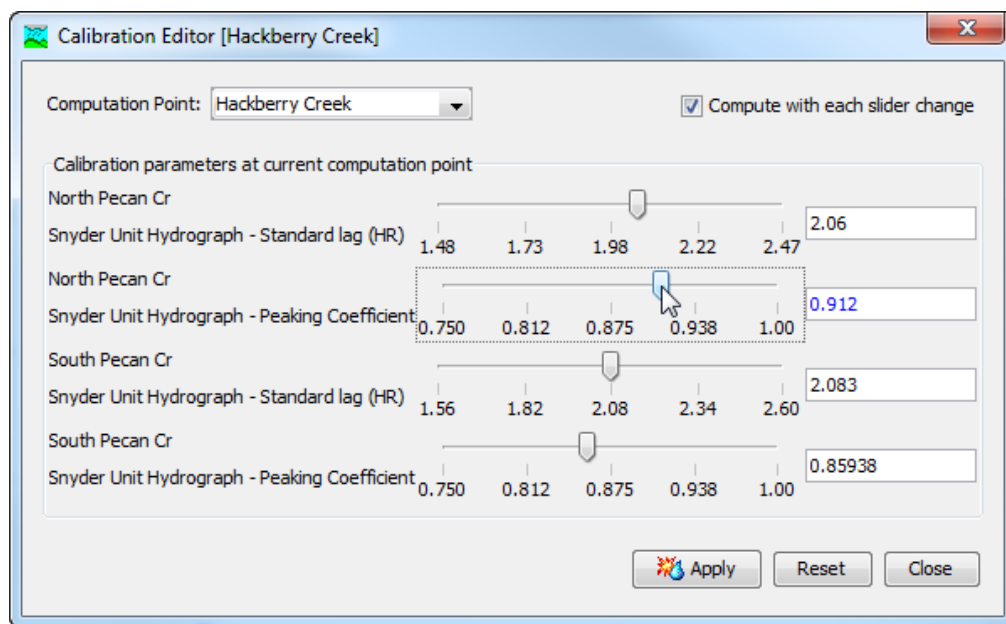

Figure 285. Using the custom calibration editor at a computation point.

Adjust a parameter value for an element using the slider bar for that parameter. Each slider bar is labeled with the element name and parameter name, including units for the parameter. Change the value by clicking with the mouse and dragging the slider. The precise selected value is shown on the right of each slider. You may optionally change the value by typing in the editor field where the precise value is displayed.

The results for the computation point and all elements upstream of it are recomputed immediately after changing a parameter value with a slider bar. In many watersheds the computations require only a few seconds to complete. However, some complex watersheds require more time to recompute the results. In these cases you can use the checkbox in the upper right to control when results are recomputed. When the checkbox is engaged, results are recomputed after every slider change. When the checkbox is disengaged, results are only recomputed when the **Apply** button is pressed.

The result graphs will automatically update to reflect changes made with the customizable editor. Updated results automatically replace the results shown in each graph as soon as a recompute is complete.

Sometimes you may wish to abandon all the parameter adjustments you have made and start over with the calibration. Press the **Reset** button to return the parameter values in the customizable editor to the values in place when the editor first opened.

### ***Computing Multiple Runs***

Multiple simulation runs can be computed in rapid succession. Each run included for simulation is internally managed the same as if it were computed in isolation. The steps automatically performed for the user begin with selecting the simulation run, checking parameters for the run, and finally computing the simulation. This sequence is repeated in rapid succession for each simulation run in the selected set. Appropriate feedback is provided through a progress bar.

The multiple simulation runs must exist before they can be selected for a multiple compute. Select the **Multiple Compute** command on the **Compute** menu. A manager is used to select simulation runs (Figure 286). Make selections in the list and then press the **Compute** button to begin computing the selected runs. A separate progress bar will be displayed for each simulation run as it is computed. The progress bar may disappear automatically at the conclusion of a simulation run depending on the configurations in the *Program Settings*. If errors are encountered while computing a run, the progress bar will always remain visible after all selected runs have finished computing regardless of any other settings.

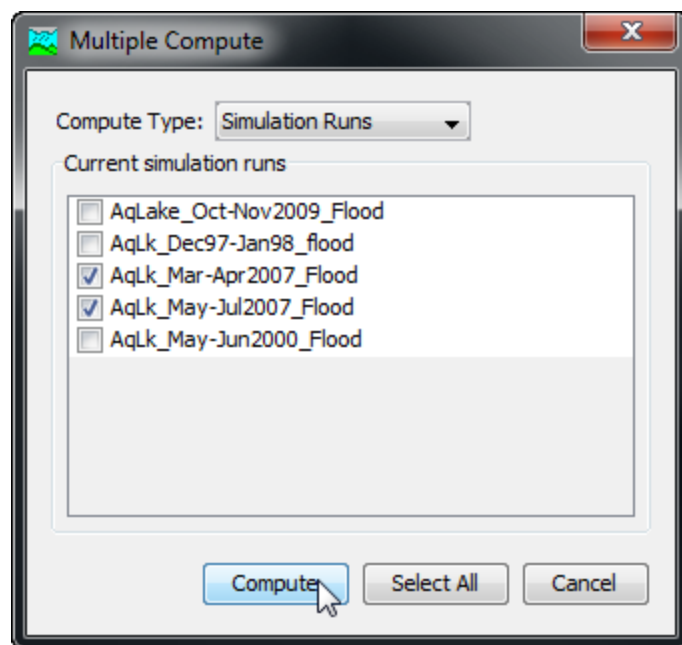

Figure 286. Selecting multiple simulation runs for sequential compute.

## Viewing Results for the Current Run

A variety of graphical and tabular results are available after a simulation run is computed. The same results are also available for the current run, so long as no data used in the simulation has changed. The program tracks all of the data in the simulation run, the selected basin model, the selected meteorologic model, and the selected control specifications. It also tracks any time-series data, paired data, or grid data used in the basin and meteorologic models. Results for a simulation run can only be accessed when none of this data has changed since the last time the run was computed. If any of the data has changed, you will need to recompute the simulation run before you will be allowed to start accessing results.

Once a result is open for viewing it will remain open until it is closed by the user. It is possible that data used during the simulation that produced the result could change while the result is open for viewing. In this case, the open result will immediately show an indication that data has changed and the simulation run needs to be recomputed. After the run is recomputed the open results are automatically updated with the new results and the indication is updated with the date and time of the most-recent compute.

## **Global Summary Table**

There are two ways to access the global summary results for the current simulation run. Both methods show the same results (Figure 287). None of the methods allows access to the global summary table if the results need to be recomputed. In this situation you must first compute the run and then the results will be available. Once the global summary table is open, it will be automatically updated whenever the simulation run is computed.

The first method for viewing global summary results is to use the **Results** menu. Click the **Results** menu and select the **Global Summary Table** command. The menu command will only be enabled if the results for the current simulation run do not need to be recomputed. The summary table will automatically open after selecting the menu command. The table includes one row for each element in the basin model and columns for element name, drainage area, peak flow, time of peak flow, and total outflow volume. The table will open to show only those elements selected when the result was requested. Selected elements are shown in the *Basin Map* and also the *Watershed Explorer*. Optionally, you may switch to showing all elements using the selection box above the table of results.

The second method for viewing global summary results is to use the button on the toolbar. Press the toolbar button with a picture of a table plus a globe. The button will only be enabled if there is a current simulation run and the results do not need to be recomputed.

Project: castro Simulation Run: Current

Start of Run: 16Jan1973, 03:00 Basin Model: Castro 1  
 End of Run: 16Jan1973, 12:55 Meteorologic Model: GageWts  
 Compute Time: 10May2012, 11:31:15 Control Specifications: Jan73

Show Elements: All Elements Volume Un...  MM  1000 M3 Sorting: Hydrologic

Hydrologic Element	Drainage Area (KM2)	Peak Discharge (M3/S)	Time of Peak	Volume (MM)
Subbasin-3	5.63	4.0	16Jan1973, 07:25	15.6186
Reach-2	5.63	3.5	16Jan1973, 11:25	15.1046
Subbasin-4	2.49	3.1	16Jan1973, 06:50	15.4098
West Branch	8.12	5.9	16Jan1973, 06:55	15.1982
Subbasin-2	4.01	4.3	16Jan1973, 06:55	16.7040
Subbasin-1	2.23	2.8	16Jan1973, 07:05	22.3012
Reach-1	2.23	2.8	16Jan1973, 07:45	21.7426
East Branch	6.24	6.5	16Jan1973, 06:55	18.5046
Outlet	14.36	12.3	16Jan1973, 06:55	16.6350

Print Close

Figure 287. Viewing the global summary table for a simulation run. Volume in millimeters or inches is computed by dividing the volume by the drainage area.

You can choose the units for volume results. Actual volume is shown in either thousands of cubic meters (THOU M3) or in acre-feet (AC-FT). You can use the buttons above the table of results to change volume units.

You can view the elements listed either in alphabetic or hydrologic order. When hydrologic order is selected, the elements are shown in the same order as in the *Watershed Explorer*. This order represents the order determined from the flow network plus any manual adjustments. Optionally you can switch to viewing elements in alphabetic order using the selection box above the table of results.

### Individual Elements

There are three ways to access results for individual elements in the current simulation run. All methods show the same results. You must select one or more elements in the basin map before you can view results for that element.

The first method for viewing individual element results is to use the **Results** menu. You may need to first open the basin model by clicking on it in the *Watershed Explorer*, on the "Components" tab. The current simulation run is shown in brackets in the basin map title bar. Select one or more elements in the basin map by clicking with the arrow tool. With an element selected in the basin map, click the **Results** menu

and select the **Element Graph** command, the **Element Summary Table** command, or the **Element Time-Series Table** command. The appropriate result will automatically be shown in the *Desktop* area. The information included in the graph (Figure 288) varies by element type, but always includes outflow. Optional items such as observed flow, computed stage, and observed stage are also included.

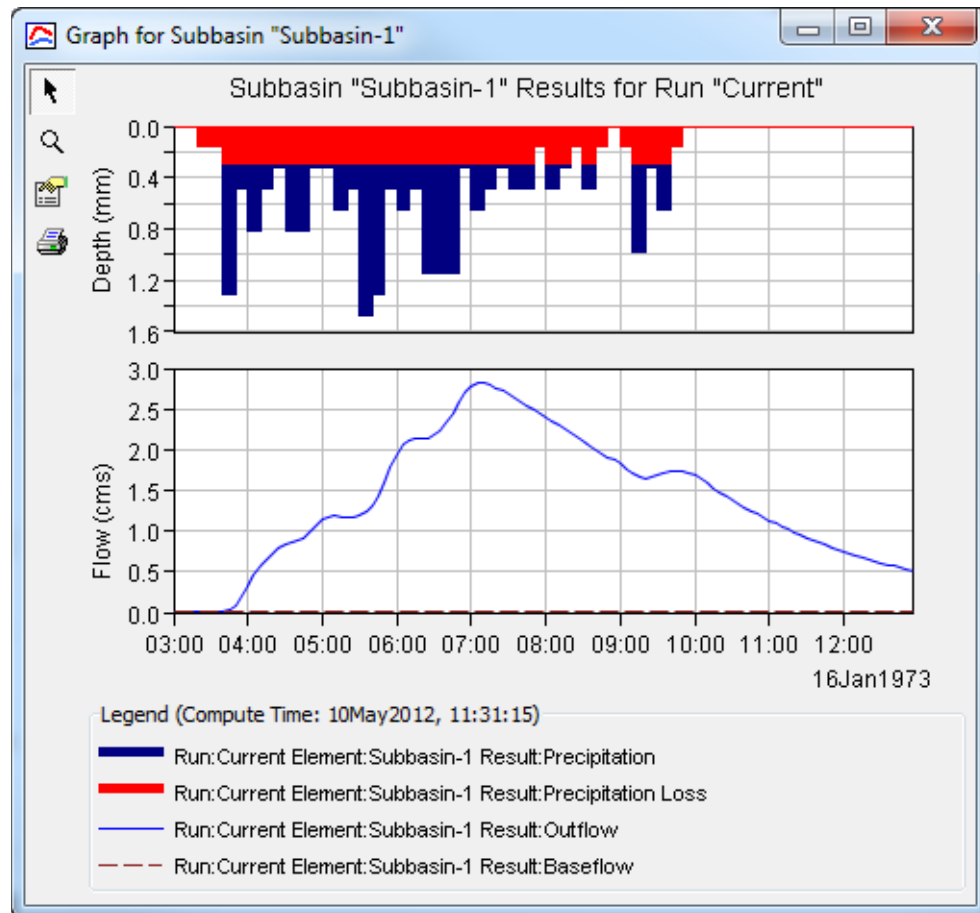

Figure 288. Element graph for a subbasin.

The information included in the summary table (Figure 289) also varies by element type but always includes the peak flow, time of peak flow, and outflow volume. The time-series table includes the same information as the graph but in numerical format (Figure 290). If you selected more than one element, then one result for each element will open. The menu commands on the **Results** menu will only be enabled if the results for the current simulation run do not need to be recomputed, and there is an element selection in the basin map.

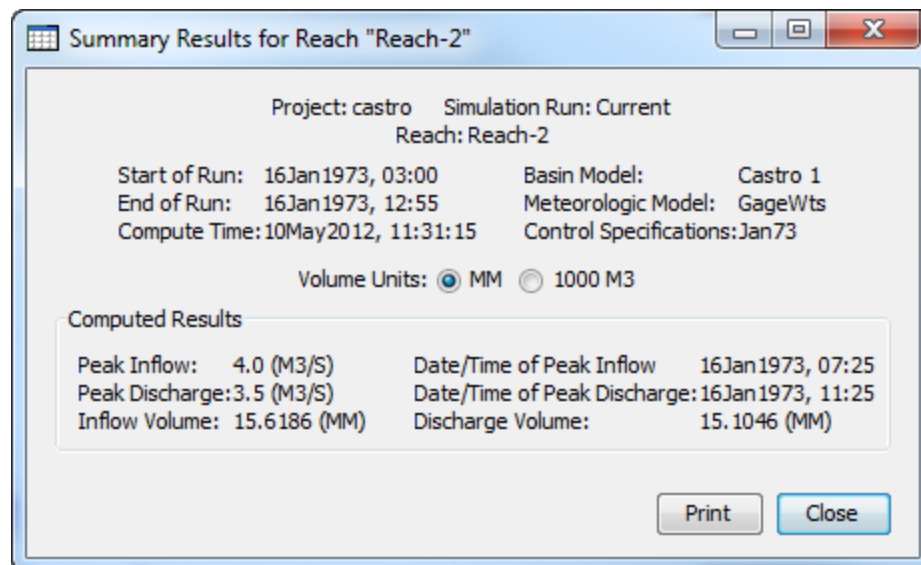

Figure 289. Element summary table for a reach.

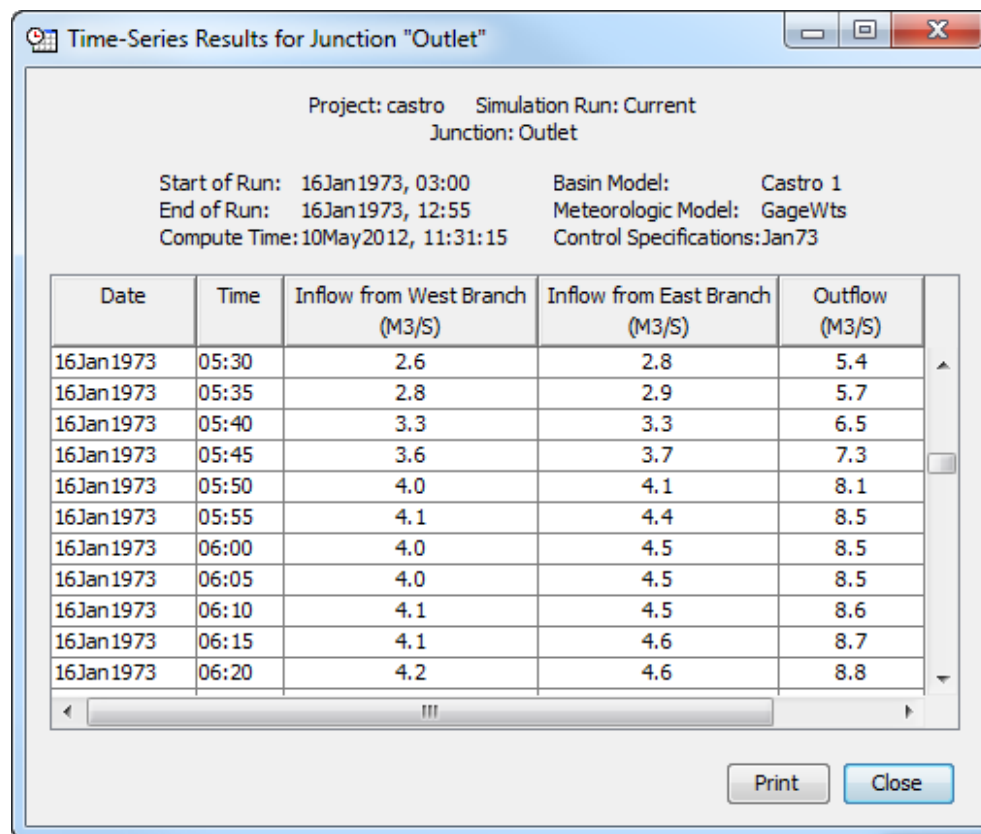

Figure 290. Element time-series table for a junction with observed flow.

The second method for viewing individual element results is to use the element icon in the basin map. Again you may need to open the basin model and select a current simulation run before attempting to view results. Click on an element to highlight it. Keep the mouse over the element and press the right mouse button. A context menu is



displayed that contains several choices including **View Results**. The name of the current simulation run is shown in brackets after the menu command. Move the mouse into the **View Results** submenu and select any of the result commands: **Graph**, **Summary Table**, or **Time-Series Table**. The appropriate result will open. If you selected more than one element, then one result for each element will open. The **View Results** menu command will only be enabled if the results for the current simulation run do not need to be recomputed.

The third method for viewing individual element results is to use the buttons on the toolbar. First you must open the basin model, select a current simulation run, and select one or more elements in the basin map by clicking with the arrow tool. Once you have a selected element, click the graph, summary table, or time-series table buttons. The button for selecting a graph shows a line plot. The button for the summary table shows a plain table. The button for the time-series table shows a table plus a clock. The appropriate result will automatically open. If you selected more than one element, then one result for each element will be added to the *Desktop*. The toolbar buttons for viewing element results will only be enabled if the results for the current simulation run do not need to be recomputed, and there is an element selection in the basin map.

## ***Viewing Results for Other Runs***

In addition to viewing results for the currently selected simulation run, it is also possible to view results for other runs that are not the current selection. Those other runs are also tracked in the same way as the current run to make sure data has not changed and results do not need to be recomputed. If any of the data in a simulation run changes, it will have to be recomputed before results can be accessed. Results for other simulation runs are accessed through the *Watershed Explorer*, on the "Results" tab.

To begin viewing results, go to the "Results" tab of the *Watershed Explorer* and click on the desired simulation run icon. If necessary, click on the "Simulation Runs" folder to expand it and view the simulation runs in the project. The simulation run icon will be disabled if any data used in the run has changed and results need to be recomputed. If any result is open at the time data changes, the affected results will be automatically updated when the simulation run is recomputed.

### ***Global Summary Table***

The global summary table can be accessed by clicking on the "Global Summary" node in the *Watershed Explorer* (Figure 291). The global

summary table will open. It is exactly the same table that can be viewed for the current simulation run. The table includes one row for each element in the basin model and columns for element name, drainage area, peak flow, time of peak flow, and total outflow volume.

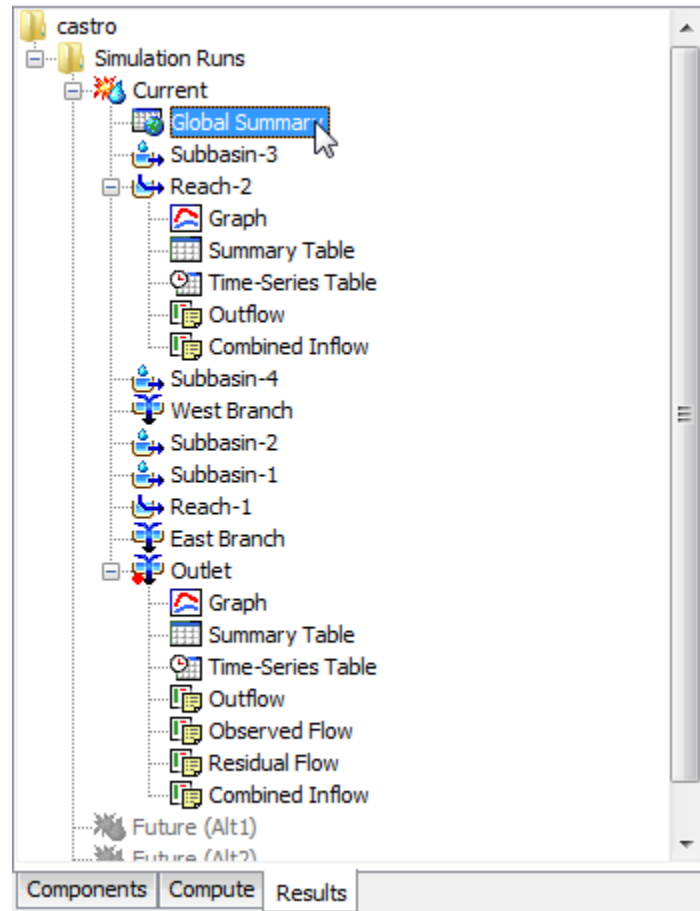

Figure 291. Accessing simulation run results from the Watershed Explorer.

### Individual Elements

Each element in the basin model is shown in the *Watershed Explorer* under the simulation run node. These elements are listed in hydrologic order below the global summary table. The results for each element are accessed by clicking on its node. The first item listed for each element is the graph; click on the "Graph" node to view the result (Figure 291). It is exactly the same graph that can be viewed for the current simulation run. The information included in the graph varies by element type but always includes outflow. Optional items such as observed flow, computed stage, and observed stage are also included. Similarly, the summary table and time-series table can also be

accessed by clicking on the "Summary Table" or "Time-Series Table" node, respectively.

### ***Element Time-Series Preview Graph***

All of the time-series data computed by an individual element are available for viewing. The time-series data are listed under each element node in the *Watershed Explorer*. The first node under each element is the graph, followed by the summary table and time-series table. The remaining nodes for each element represent the different time-series data available at that element. Click on a time-series node to preview the data in the *Component Editor*. You may select multiple time-series data by holding the shift or control key while using the mouse to click on additional nodes (Figure 292). The selected time-series may come from different elements in the same simulation run, the same element in different runs, or different elements in different runs. The selected time-series data will automatically be partitioned into groups by data type.

### ***Time-Series Tables and Graphs***

Preview graphs of selected time-series data can be opened as graphs or time-series tables within the *Desktop* area. Begin by selecting the time-series you wish to include in the graph or table. Once you have selected the desired time-series, you can press the graph or time-series table buttons on the toolbar. The chosen time-series will be graphed or tabulated (Figure 293).

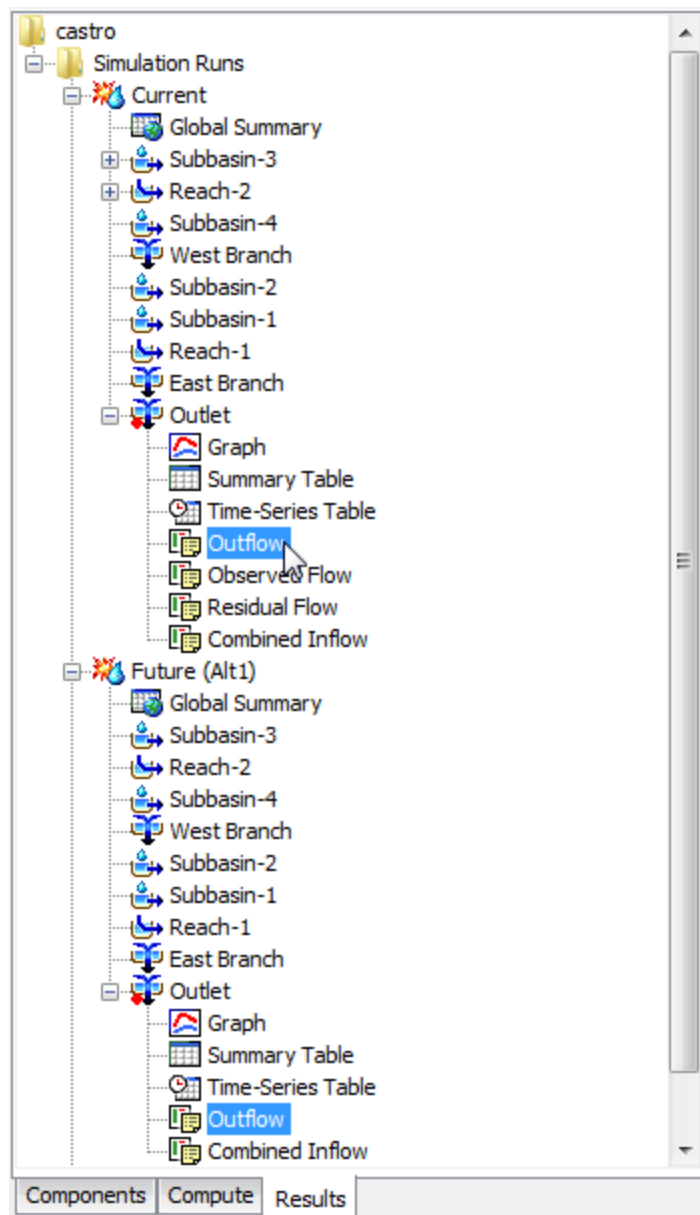

Figure 292. Selecting computed outflow from the same element in two different simulation runs. Other types of time-series data could also be selected.

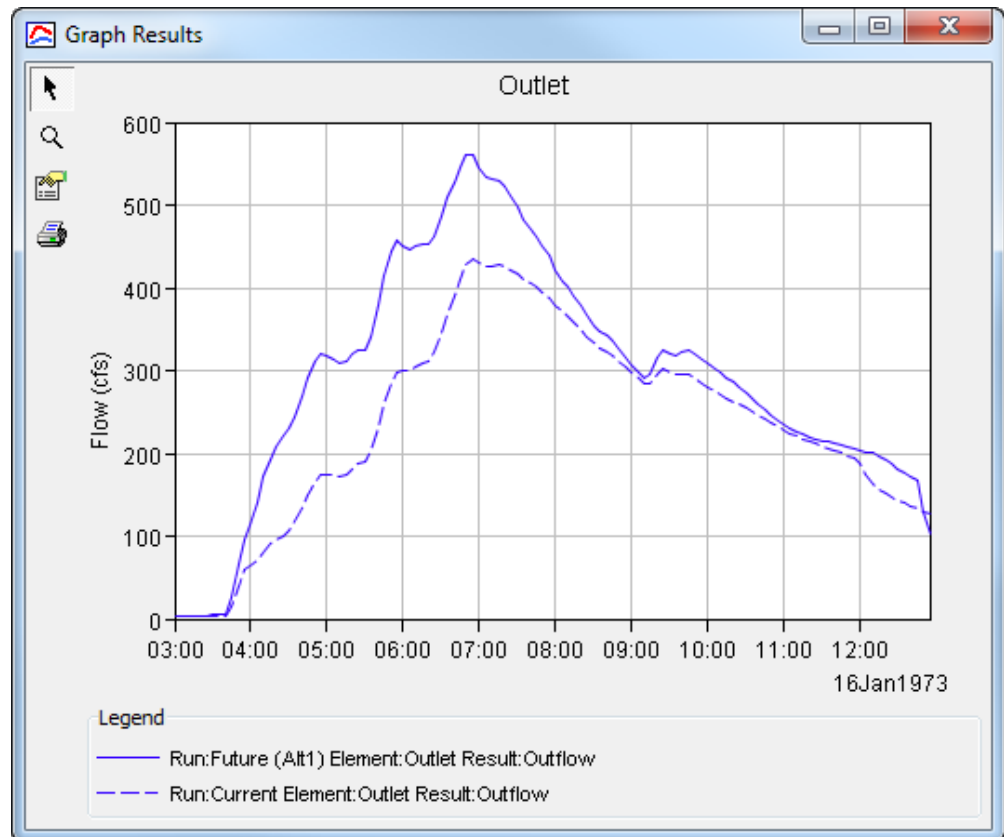

Figure 293. Custom graph created by selecting multiple time-series results for a preview and then pressing the graph button on the toolbar.

After you have opened a time-series table or graph, you may add additional time-series results. Position the mouse over the time-series result in the *Watershed Explorer* that you wish to add to the graph or table. Press and hold the left mouse button and then drag the mouse over the top of the graph or table where you want the result to be added. The mouse cursor will change to indicate which tables and graphs can accept the additional time-series. Release the mouse button while it is over the desired table or graph and it will be automatically updated to show the additional time-series results.

### Changing Graph Properties

All of the graphs that can be accessed open with default properties for line color, line style, data symbols, etc. These default properties have been selected to be appropriate for most situations. However, it is possible to customize the properties in a graph. To change the properties, first click on the graph to select it. Next go to the **Results** menu and select the **Graph Properties...** command. An editor (Figure 294) will open that can be used to change the properties of the selected graph. The properties for each time-series curve can be

changed. It is also possible to change the properties for the axis, title, gridlines, patterns, and legend.

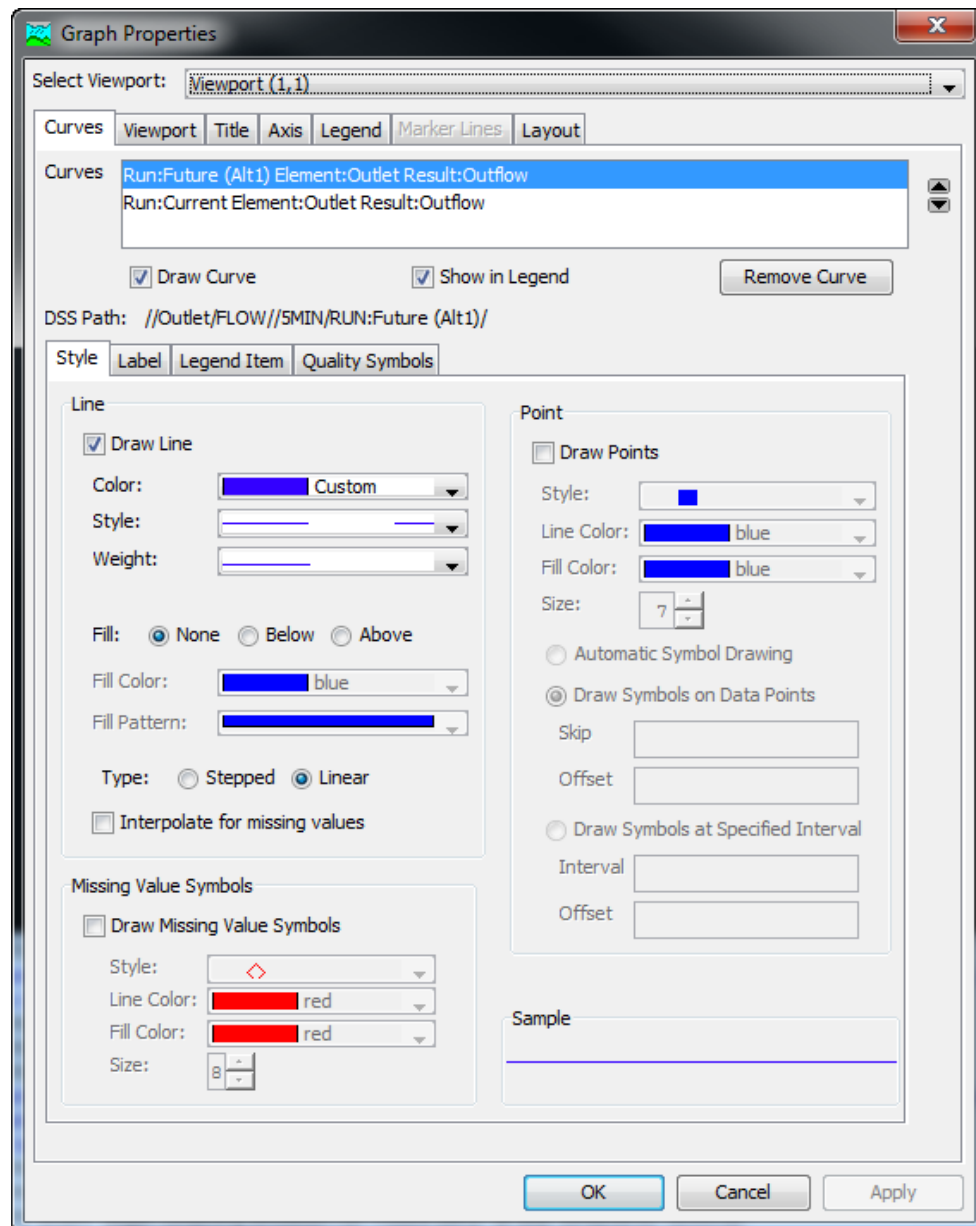

Figure 294. Editing the drawing properties for an element graph.

## CHAPTER 13

# ***Model Optimization***

This chapter describes how observed streamflow can be used to optimize model performance by automatically estimating parameters. The optimization process begins with initial parameter estimates and adjusts them so that the simulated results match the observed streamflow as closely as possible. Two different search algorithms are provided that move from the initial parameter estimates to the final best parameter estimates. A variety of objective functions are provided to measure the goodness of fit between the simulated and observed streamflow in different ways. While parameter estimation using optimization does not produce perfect results, it can be a valuable aid when calibrating models.

### ***Optimization Trials***

Parameter estimation is the process of adapting a general model to a specific watershed. Some parameters can be estimated directly from field measurements. For example, the area that must be entered for a subbasin element can be measured directly in the field using standard surveying procedures or from maps developed through surveying. Other parameters can be estimated indirectly from field measurements. In this case, the field measurement does not result in a value that can be input directly to the program. However, the field measurement can provide a strong recommendation for a parameter in the program based on previous experience. For example, measurements of soil texture are correlated with parameters such as hydraulic conductivity. Finally, there are parameters that can only be estimated by comparing computed results to observations such as measured streamflow. Even for parameters of the first two types, there is often enough uncertainty in the true parameter value to require some adjustment of the estimates in order for the model to closely follow the observed streamflow.

The quantitative measure of the goodness-of-fit between the computed result from the model and the observed flow is called the objective function. An objective function measures the degree of variation between computed and observed hydrographs. It is equal to zero if the hydrographs are exactly identical. The key to automated parameter estimation is a search method for adjusting parameters to minimize the objective function value and find optimal parameter values. A minimum objective function is obtained when the parameter

values best able to reproduce the observed hydrograph are found. Constraints are set to insure that unreasonable parameter values are not used.

Optimization trials are one of the components that can compute results. Each trial is composed of a basin model, meteorologic model, and time control information. The trial also includes selections for the objective function, search method, and parameters to be adjusted in order to find an optimal model. A variety of result graphs and tables are available from the *Watershed Explorer* for evaluating the quality of the results.

The iterative parameter estimation procedure used by the program is often called optimization. Initial values for all parameters are required at the start of the optimization trial time window. A hydrograph is computed at a target element by computing all of the upstream elements. The target must have an observed hydrograph for the time period over which the objective function will be evaluated. Only parameters for upstream elements can be estimated. The value of the objective function is computed at the target element using the computed and observed hydrographs. Parameter values are adjusted by the search method and the hydrograph and objective function for the target element are recomputed. This process is repeated until the value of the objective function is sufficiently small, or the maximum number of iterations is reached. Results can be viewed after the optimization trial is complete.

### ***Creating a New Optimization Trial***

A new optimization trial is created using a wizard that helps you navigate the steps to creating a new trial. There are two ways to access the wizard. The first way to access the wizard is to click on the **Compute** menu and select the **Create Compute ⇒ Optimization Trial** command; it is only enabled if at least one basin model and meteorologic model exist. The wizard will open and begin the process of creating a new optimization trial. The second way to access the wizard is from the *Optimization Trial Manager*. Click on the **Compute** menu and select the **Optimization Trial Manager** command. The *Optimization Trial Manager* will open and show any trials that already exist. Press the **New...** button to access the wizard and begin the process of creating an optimization trial, as shown in Figure 295.



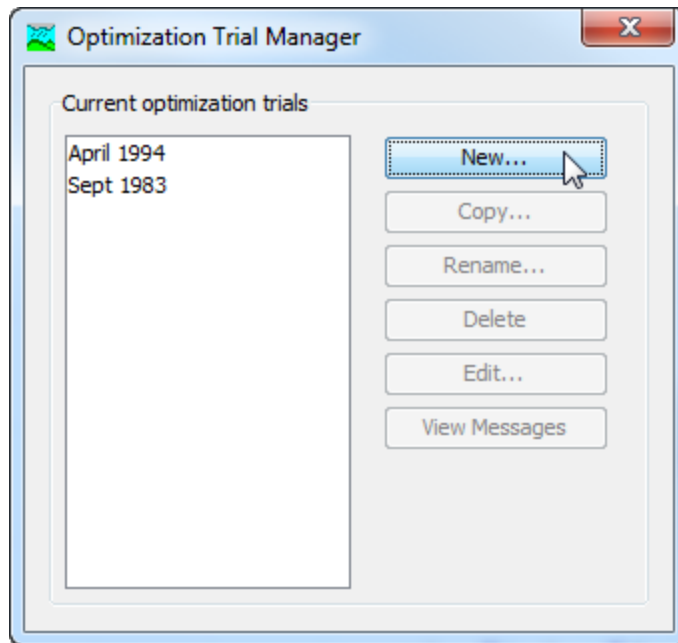

Figure 295. Beginning the process of creating a new optimization trial using the Optimization Trial Manager.

The first step of creating an optimization trial is to provide the name for the new trial (Figure 296). A default name is provided for the new optimization trial; you can use the default or replace it with your own choice. After you finish creating the trial you can add a description to it. If you change your mind and do not want to create a new optimization trial, you can press the **Cancel** button at the bottom of the wizard or the **X** button in the upper right corner of the wizard. The **Cancel** button can be pressed at any time you are using the wizard. Press the **Next>** button when you are satisfied with the name you have entered and are ready to proceed to the next step.

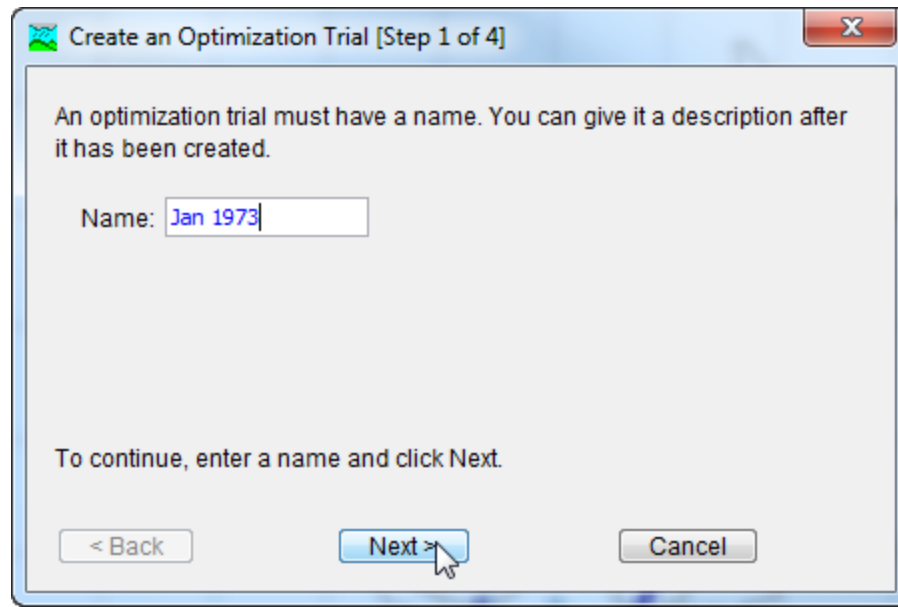

Figure 296. Entering a name for a new optimization trial. The remaining steps are to select a basin model, the optimization location, and a meteorologic model.

The second step of creating an optimization trial is to select a basin model. All of the basin models that are currently part of the project are displayed in alphabetical order. By default the first basin model in the table is selected. The selected basin model is highlighted. You can use your mouse to select a different basin model by clicking on it in the table of available choices. You can also use the arrow keys on your keyboard to select a different basin model. Press the **Next>** button when you are satisfied with the basin model you have selected and are ready to proceed to the next step. Press the **<Back** button if you wish to return to the previous step and change the name for the new optimization trial.

The third step of creating an optimization trial is to select an element where there is observed flow. The element is where the objective function will be evaluated. You will only be able to perform parameter estimation at, or upstream of the selected element. The elements in the selection list come from the basin model used in the simulation run that was selected in the previous step. By default the first element in the table is selected. The selected element is always highlighted. You can use your mouse to select a different element by clicking on it in the table of available choices. You can also use the arrow keys on your keyboard to select a different element. Press the **Next>** button when you are satisfied with the element you have selected and are ready to proceed to the next step. Press the **<Back** button if you wish to return to the previous step and change the selected basin model for the new optimization trial.

The fourth step of creating an optimization trial is to select a meteorologic model. All of the meteorologic models that are currently part of the project are displayed in alphabetical order. By default the first meteorologic model in the table is selected. The selected meteorologic model is highlighted. You can use your mouse to select a different meteorologic model by clicking on it in the table of available choices. You can also use the arrow keys on your keyboard to select a different meteorologic model. You are responsible for selecting a basin model in step two and a meteorologic model in this step that will successfully combine to compute results. Press the **Finish** button when you are satisfied with the name you have entered, the basin model and element you selected, the meteorologic model you selected, and are ready to create the optimization trial. Press the **<Back** button if you wish to return to the previous step and select a different element for comparing computed results and computing the objective function.

### ***Copying an Optimization Trial***

There are two ways to copy an optimization trial. Both methods for copying a trial create an exact duplicate with a different name. Once the copy has been made it is independent of the original and they do not interact.

The first way to create a copy is to use the *Optimization Trial Manager*, which is accessed from the **Compute** menu. Select the optimization trial you wish to copy by clicking on it in the list of current optimization trials. The selected trial is highlighted after you select it. After you select a trial you can press the **Copy...** button on the right side of the window. The *Copy Optimization Trial* window (Figure 297) will open where you can name and describe the copy that will be created. A default name is provided for the copy; you can use the default or replace it with your own choice. A description can also be entered; if it is long you can use the button to the right of the description field to open an editor. When you are satisfied with the name and description, press the **Copy** button to finish the process of copying the selected optimization trial. You cannot press the **Copy** button if no name is specified. If you change your mind and do not want to copy the selected optimization trial, press the **Cancel** button or the **X** button in the upper right to return to the *Optimization Trial Manager* window.

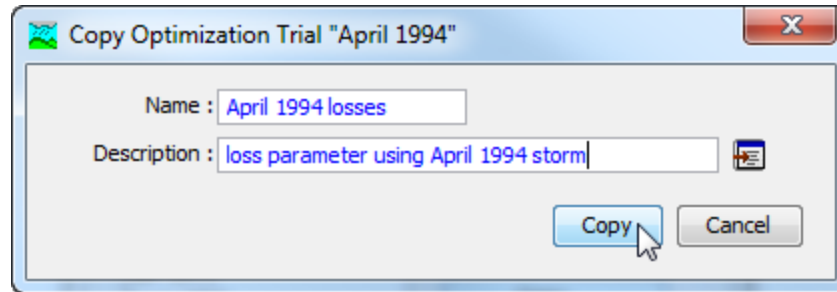

Figure 297. Creating a copy of an optimization trial.

The second way to copy is from the "Compute" tab of the *Watershed Explorer*. Move the mouse over the optimization trial you wish to copy and press the right mouse button (Figure 298). A context menu is displayed that contains several choices including copy. Click the **Create Copy...** command. The *Copy Optimization Trial* window will open where you can name and describe the copy that will be created. A default name is provided for the copy; you can use the default or replace it with your own choice. A description can also be entered; if it is long you can use the button to the right of the description field to open an editor. When you are satisfied with the name and description, press the **Copy** button to finish the process of copying the selected optimization trial. You cannot press the **Copy** button if no name is specified. If you change your mind and do not want to copy the selected optimization trial, press the **Cancel** button or the **X** button in the upper right of the *Copy Optimization Trial* window to return to the *Watershed Explorer*.

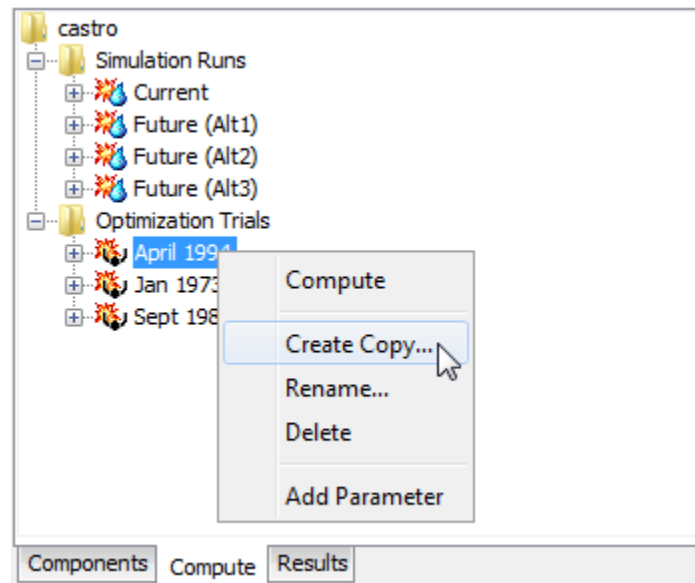

Figure 298. Copying an optimization trial from the *Watershed Explorer*. The *Copy Optimization Trial* window will appear after the **Create Copy...** menu command is selected.

## ***Renaming an Optimization Trial***

There are two ways to rename an optimization trial. Both methods for renaming a trial change its name and perform other necessary operations.

The first way to perform a rename is to use the *Optimization Trial Manager*, which you can access from the **Compute** menu. Select the optimization trial you wish to rename by clicking on it in the list of current optimization trials. The selected trial is highlighted after you select it. After you select a trial you can press the **Rename...** button on the right side of the window. The *Rename Optimization Trial* window (Figure 299) will open where you can provide the new name. If you wish you can also change the description at the same time. If the new description will be long, you can use the button to the right of the description field to open an editor. When you are satisfied with the name and description, press the **Rename** button to finish the process of renaming the selected optimization trial. You cannot press the **Rename** button if no name is specified. If you change your mind and do not want to rename the selected simulation trial, press the **Cancel** button or the **X** button in the upper right of the *Rename Optimization Trial* window to return to the *Optimization Trial Manager* window.

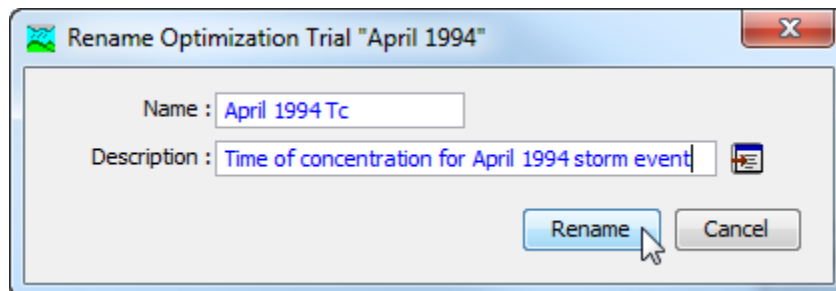

Figure 299. *Renaming an optimization trial. This was accessed from the Optimization Trial Manager.*

The second way to rename is from the "Compute" tab of the *Watershed Explorer*. Select the optimization trial you wish to rename by clicking on it in the *Watershed Explorer*; it will become highlighted. Keep the mouse over the selected trial and click the left mouse button again. The highlighted name will change to editing mode (Figure 300). You can then move the cursor with the arrow keys on the keyboard or by clicking with the mouse. You can also use the mouse to select some or all of the name. Change the name by typing with the keyboard. When you have finished changing the name, press the **Enter** key to finalize your choice. You can also finalize your choice by clicking elsewhere on the "Compute" tab. If you change your mind while in editing mode and do not want to rename the selected optimization trial, press the **Escape** key.

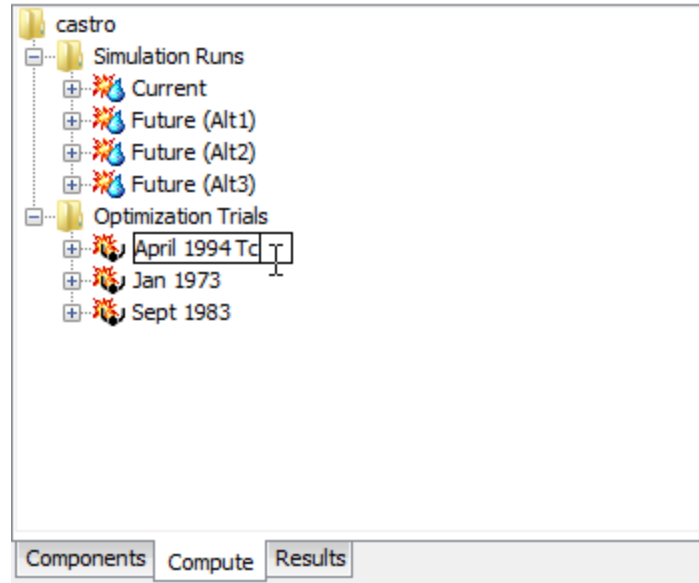

Figure 300. Renaming an optimization trial in the Watershed Explorer.

### ***Deleting an Optimization Trial***

There are two ways to delete an optimization trial. Both methods for deleting a trial remove it from the project and automatically delete previously computed results. Once a trial has been deleted it cannot be retrieved or undeleted.

The first way to perform a deletion is to use the *Optimization Trial Manager*, which you can access from the **Compute** menu. Select the optimization trial you wish to delete by clicking on it in the list of current optimization trials. The selected trial is highlighted after you select it. After you select a trial you can press the **Delete** button on the right side of the window. A window will open where you must confirm that you wish to delete the selected trial as shown in Figure 301. Press the **OK** button to delete the trial. If you change your mind and do not want to delete the selected optimization trial, press the **Cancel** button or the **X** button in the upper right to return to the *Optimization Trial Manager* window.

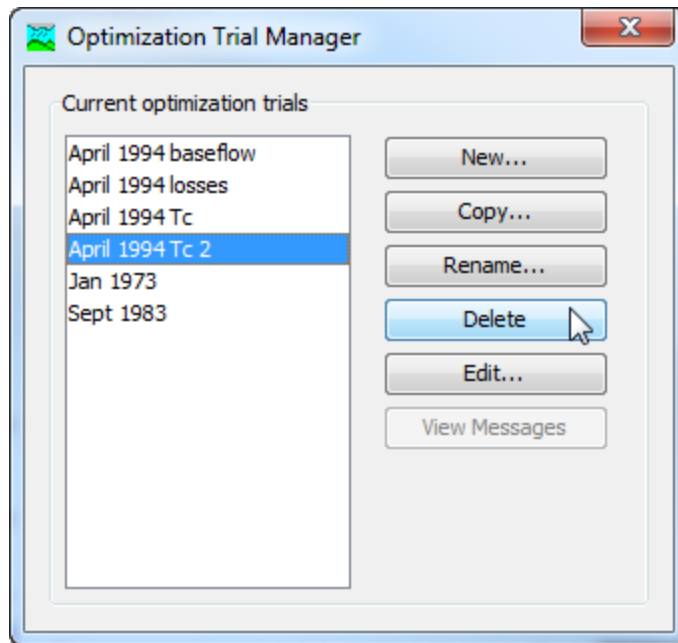

Figure 301. Preparing to delete an optimization trial from the Optimization Trial Manager. A confirmation will be required after pressing the **Delete** button.

The second way to delete is from the "Compute" tab of the *Watershed Explorer*. Select the optimization trial you wish to delete by clicking on it in the *Watershed Explorer*; it will become highlighted (Figure 302). Keep the mouse over the selected trial and click the right mouse button. A context menu is displayed that contains several choices including delete. Click the **Delete** command. A window will open where you must confirm that you wish to delete the selected trial. Press the **OK** button to delete the trial. If you change your mind and do not want to delete the selected optimization trial, press the **Cancel** button or the **X** button in the upper right to return to the *Watershed Explorer*.

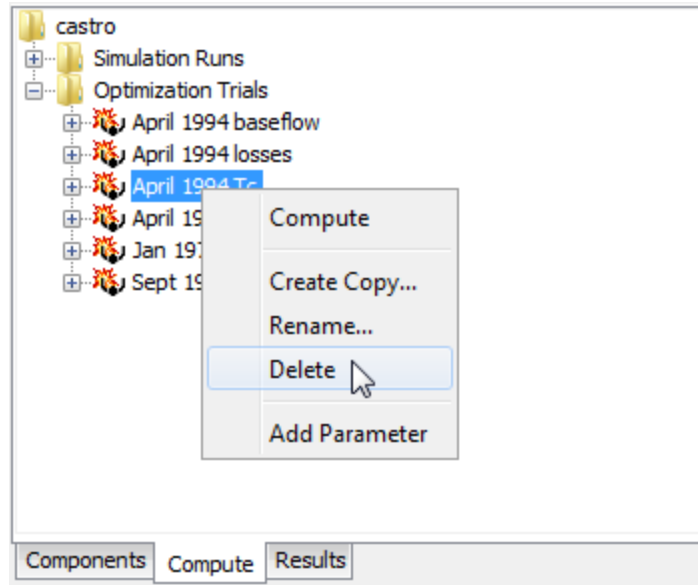

Figure 302. Deleting an optimization trial in the Watershed Explorer.

## Selecting Components

One of the principal tasks when creating an optimization trial using the wizard is the selection of the components that will be used to compute optimization results. The components include the basin model and the hydrologic element in the basin model where the objective function will be computed. The components also include the meteorologic model. These components are selected when creating a new optimization trial with the wizard. However, you can change the basin model and meteorologic model you wish to use at any time using the *Component Editor* for the optimization trial. Access the *Component Editor* from the "Compute" tab of the *Watershed Explorer* (Figure 303). If necessary, click on the "Optimization Trials" folder to expand it and view the available optimization trials. The *Component Editor* contains a basin model selection list that includes all of the basin models in the project where the basin model has at least one element with observed flow. The *Component Editor* also contains a meteorologic model selection list that includes all of the meteorologic models in the project. The element where the objective function will be computed can also be changed, but that function is performed in a different *Component Editor* that will be described later.



**Optimization Trial**

**Name: Jan 1973**

Description: General optimization of for Jan 19: [icon]

\*Basin Model: Castro 1 [icon]

\*Meteorologic Model: GageWts [icon]

\*Start Date (ddMMYYYY) 16Jan1973

\*Start Time (HH:mm) 03:00

\*End Date (ddMMYYYY) 16Jan1973

\*End Time (HH:mm) 12:55

Time Interval: 5 Minutes [icon]

Method: Univariate Gradient [icon]

Tolerance: 0.0100000

Max Iterations: 50

Figure 303. The optimization trial component editor can be used to change the selected components, time window, and search tolerance.

## Entering a Time Window

You must enter a start date and time and an end date and time for the optimization trial. The time control information is not specified in the wizard used to create the optimization trial. The time control information must be entered after the trial is created using the *Component Editor* for the optimization trial (Figure 303). Enter the start date using the indicated format for numeric day, abbreviated month, and four-digit year. Enter the end date using the same format. The start time and end time are entered using 24-hour time format.

## Search Method

Two search methods are available for minimizing the objective function and finding optimal parameter values. The univariate gradient method evaluates and adjusts one parameter at a time while holding other parameters constant. The Nelder and Mead method uses a downhill simplex to evaluate all parameters simultaneously and determine which parameter to adjust. The default method is the univariate gradient method. Also, the univariate gradient method is always used if only one parameter is selected.

Selecting the search method for the optimization trial is accessed from the "Compute" tab of the *Watershed Explorer* in the optimization trial *Component Editor*. Click on the optimization trial node to display the *Component Editor* for the optimization trial (Figure 303). If necessary,

click on the "Optimization Trials" folder to expand it and view the available optimization trials in the project.

Two methods are provided for controlling the search process with the univariate gradient or Nelder Mead methods. Both search methods function by iteratively adjusting parameter values to lower the objective function value; each parameter adjustment is termed an "iteration." The tolerance determines the change in the objective function value between two successive iterations that will terminate the search. That is, when the objective function changes less than the specified tolerance, the search terminates. The maximum number of iterations also can be used to limit the search. The search will stop when the maximum number of iterations is reached regardless of changes in the objective function value or the quality of the estimated parameters. The tolerance and maximum iterations are both entered on the optimization trial Component Editor (Figure 303). Defaults are provided for both criteria. The initial default values depend on the selected search method.

### **Objective Function**

The objective function measures the goodness-of-fit between the computed outflow and observed streamflow at the selected element. Eight different functions are provided that measure the goodness-of-fit in different ways. The RMS error function calculates the classical root mean square error. The peak-weighted RMS error function is a modification of the standard root mean square error that gives greatly increased weight to flows above average and less weight to flows below average. The RMS log error uses the root-mean-square error of the logarithm-transformed flows to emphasize small flows compared to large flows. The sum of squared residuals function gives increased weight to large errors and less weight to small errors. The sum of absolute residuals function gives equal weight to large and small errors. The percent error in peak flow function ignores the entire hydrograph except for the single peak flow value. The percent error in volume function ignores peak flow or timing considerations in favor of the volume. The time-weighted function gives greater weight to error near the end of the optimization time window and less weight to errors early in the window.

Select the objective function method for the optimization trial on the *Component Editor* for the objective function (Figure 304). Access the *Component Editor* from the "Compute" tab of the *Watershed Explorer*. If necessary, click on the "Optimization Trials" folder to expand it and view the available optimization trials in the project. Click on the optimization trial node to expand it and see the objective function node.

Click on the objective function node to view the editor. The objective function method is the first item in the *Component Editor*.

Figure 304. Specifying properties for the objective function using the component editor.

An element with observed flow was selected at the time the optimization trial was created. This is the location where the objective function will be evaluated. You can change the element location at any time using the *Component Editor* for the objective function. The selection list shows all of the elements with observed flow in the basin model selected for the optimization trial. Select a different element in the list to change where the objective function will be evaluated. Recognize that parameters can only be estimated at locations upstream of the selected element. Changing the location will change which parameters can be estimated.

In general, the observed flow record at the selected element location should not contain any missing data. However, you can specify the amount of missing data in the observed flow that will be permitted. Specify the amount that may be missing as a percentage. The program will check the observed flow record and only perform the optimization if the percentage of missing flow in the record is less than the specified amount. Time steps with missing data are ignored when computing the value of the objective function. The default amount of missing flow is 0.0 percent.

The objective function is evaluated over a specified time window. The time window cannot begin before the start time of the optimization trial. Also, the time window cannot end after the end time of the optimization trial. However, you have the option of changing the time window to be narrower than the one specified for the whole optimization trial. By default, the start and end time for the objective function will default to the time window of the optimization trial.

## ***Adding and Deleting Parameters***

The parameters that will be automatically estimated must be at the selected element location or upstream of it in the element network. When the selected location is changed, elements will be automatically deleted if they are not upstream of the newly selected location. Parameters that can be chosen for estimation are a selected set of the canopy, surface, lossrate, transform, baseflow parameters in the subbasin, and routing parameters in the reach. Parameters that should be strictly measured in the field are not allowed to be estimated. For example, it is not permissible to estimate subbasin area or a reach length.

Care must be taken when selecting parameters for estimation. While it is possible to select the same parameter more than once, it is not recommended. In this scenario, the search method attempts to improve estimates by adjusting the same parameter value at different and sometimes conflicting points in the search. This can lead to a so-called blocking condition where the search method cannot accurately determine how to adjust parameters to improve the objective function and less than optimal results are achieved.

Care must also be taken when selecting parameters at elements upstream of the observed flow location. It is possible to select multiple parameters that have similar affects on the computed hydrograph at the evaluation location. In this case, adjustments to one parameter can off set adjustments in others. For example, estimates of the time of concentration at multiple subbasins upstream of the evaluation location often result in poor results. Special parameters called scale factors have been included that adjust all similar parameters upstream of the evaluation location together in the same direction. However, care is still required even with this special scaling.

Add a new parameter to an optimization trial using the *Watershed Explorer*. Move the mouse over the optimization trial and press the right mouse button (Figure 305). A context menu is displayed that contains several choices including adding a parameter. Click the **Add Parameter** command. The subbasin canopy parameters that can be added are shown in Table 24. Subbasin surface parameters are shown in Table 25 and loss rate parameters are shown in Table 26. Subbasin transform parameters are shown in Table 27 and baseflow parameters are shown in Table 28. Reach routing parameters that can be added are shown in Table 29.

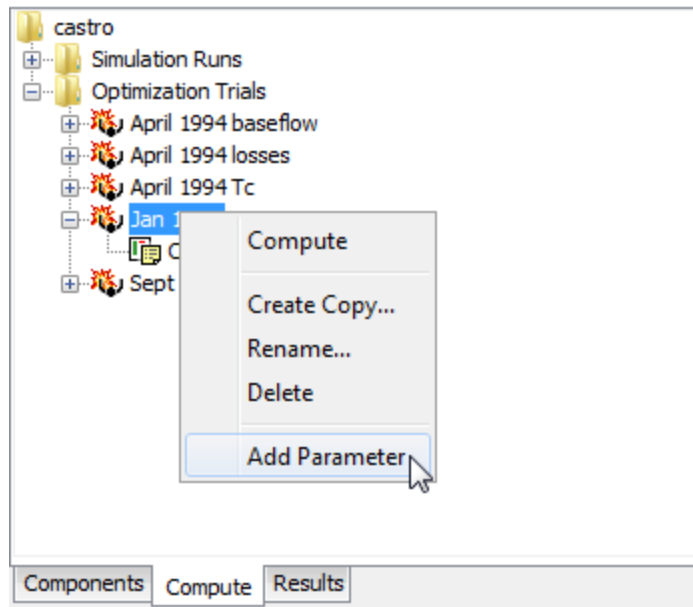

Figure 305. Adding a parameter to an optimization trial.

Delete a parameter from an optimization trial using the *Watershed Explorer*. Select the parameter you wish to delete by clicking on it in the *Watershed Explorer*; it will become highlighted. Keep the mouse over the selected parameter and click the right mouse button (Figure 306). A context menu is displayed that contains several choices including deleting a parameter. Click the **Delete Parameter** command.

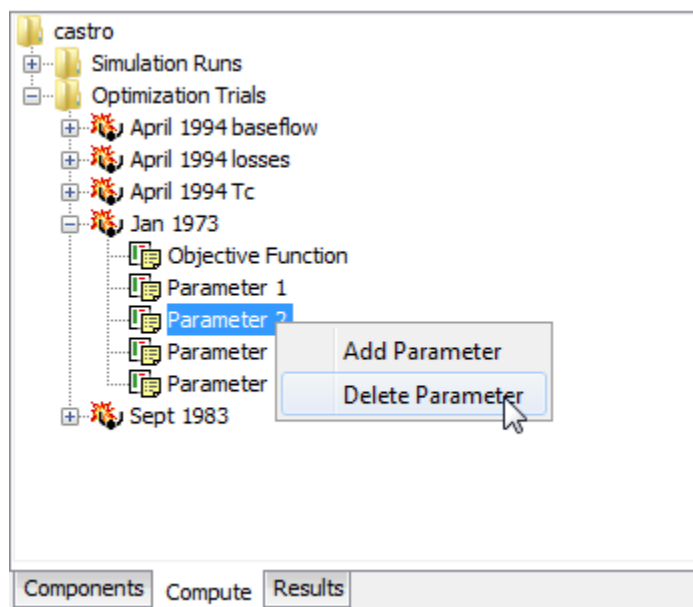

Figure 306. Deleting a selected parameter from an optimization trial.

Table 24. Subbasin canopy parameters available for optimization.

Method	Parameter
Dynamic	Initial Storage
Gridded Simple	Initial Storage
Simple	Initial Storage Maximum Storage

Table 25. Subbasin surface parameters available for optimization.

Method	Parameter
Gridded Simple	Initial Storage
Simple	Initial Storage Maximum Storage

Table 26. Subbasin loss rate parameters available for optimization.

Method	Parameter
Curve Number	Initial Abstraction Constant Rate
Deficit Constant	Initial Deficit Maximum Deficit Constant Rate
Exponential	Initial Range Initial Coefficient Coefficient Ratio Exponent
Green Ampt	Initial Content Saturated Content Suction Conductivity
Gridded Curve Number	Initial Abstraction Ratio Potential Retention Scale Factor

Table 26. Continued

<b>Method</b>	<b>Parameter</b>
Gridded Deficit Constant	Initial Deficit Ratio
	Maximum Deficit Ratio
	Constant Rate Ratio
	Impervious Area Ratio
Gridded SMA	Soil Initial Storage
	Groundwater 1 and 2 Initial Storage
Initial Constant	Initial Loss
	Constant Rate
Smith Parlange	Initial Content
	Residual Content
	Saturated Content
	Bubbling Pressure
	Pore Distribution
	Conductivity
	Beta Zero
Soil Moisture Accounting	Soil Initial Storage
	Soil Storage
	Soil Tension Storage
	Soil Percolation
	Groundwater 1 and 2 Initial Storage

Table 27. Subbasin transform parameters available for optimization.

Method	Parameter
Clark	Time of Concentration
	Storage Coefficient
Kinematic Wave	Plane Roughness
	Subcollector, Collector, and Main Channel Manning's n
ModClark	Time of Concentration
	Storage Coefficient
SCS	Time Lag
S-Graph	Time Lag
Snyder	Peaking Coefficient
	Standard Lag

Table 28. Subbasin baseflow parameters available for optimization.

Method	Parameter
Bounded	Initial Flow Rate or Initial Flow Rate per Area <sup>1</sup>
Recession	Recession Constant
Linear Reservoir	GW 1 and 2 Initial Flow Rate or Initial Flow Rate per Area <sup>1</sup>
	Groundwater 1 and 2 Storage Coefficient
	Groundwater 1 and 2 Number of Steps
Nonlinear	Initial Flow Rate or Initial Flow Rate per Area <sup>1</sup>
Boussinesq	Characteristic Length
	Hydraulic Conductivity
	Drainable Porosity
	Threshold Ratio or Threshold Flow Rate <sup>2</sup>
Recession	Initial Flow Rate or Initial Flow Rate per Area <sup>1</sup>
	Recession Constant
	Threshold Ratio or Threshold Flow Rate <sup>2</sup>

<sup>1</sup> The available parameter depends on the method selected for specifying the initial condition.

<sup>2</sup> The available parameter depends on the method selected for specifying the recession threshold.



Table 29. Reach routing parameters available for optimization.

Method	Parameter
Kinematic Wave	Manning's n
Lag	Lag
Modified Puls	Subreaches Initial Flow
Muskingum	K X Subreaches
Muskingum Cunge	Manning's n
Straddle Stager	Lag Duration

### ***Specifying Parameter Information***

A variety of information must be specified for each optimization parameter in order for the search method to function. Select the parameter you wish to edit by clicking on it in the *Watershed Explorer*. Click on the optimization trial node to expand it. The first node under the optimization trial will be the objective function. Following the objective function will be a separate node for each parameter. Click on the desired node in the *Watershed Explorer* to view the *Component Editor* for the optimization.

Each optimization parameter must select the element where the desired parameter resides. All eligible subbasin and reach elements upstream of the objective function evaluation location are shown in the selection list. Eligible subbasins are those using the methods listed in Table 24, Table 25, Table 26, Table 27, and Table 28. Eligible reaches are those using the methods listed in Table 29. Choosing an element from the list will update the list of available parameters based on the methods in use at that selected element. You may also have the choice of selecting the "All Subbasins" option in order to apply scale factors.

Each optimization parameter must select a specific parameter for the chosen element. The available choices are shown in the selection list. Once you make a choice from the list, the remainder of the data in the *Component Editor* will become available for use (Figure 307).

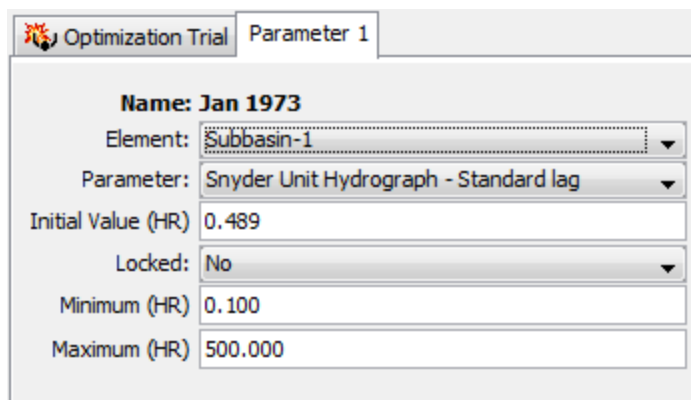

Optimization Trial		Parameter 1
<b>Name: Jan 1973</b>		
Element:	Subbasin-1	
Parameter:	Snyder Unit Hydrograph - Standard lag	
Initial Value (HR)	0.489	
Locked:	No	
Minimum (HR)	0.100	
Maximum (HR)	500.000	

Figure 307. Specifying properties for a parameter in an optimization trial.

The initial value is the starting point for the parameter estimation process. The search method will begin searching from that point for optimal parameter values. The default initial value is the parameter value in the basin model that was selected for the optimization trial. You may change the initial value without affecting the basin model.

It is possible to lock a parameter. When a parameter is locked, the initial value is used and no adjustments are made during the search process.

The minimum parameter value can be used to narrow the lower end of the range of values that will be used by the search method. Likewise, the maximum parameter value can be used to narrow the upper end of the range of values that will be used by the search method. A good source of information for narrowing the search range is preliminary estimates from field measurements or manual calibration. Default values for the minimum and maximum are provided based on physical and numerical limits. The search may continue outside the specified range. When it does so, a penalty is applied that is proportional to the distance outside the specified range. The penalty nudges the search for optimal parameter values back to the range between the specified minimum and maximum.

## Computing Results for a Trial

Results for an optimization trial are generated by computing it. Changes in all the components used in the trial are automatically tracked to determine if the results are current. When the results are no longer current, the trial must be recomputed in order to refresh the results. Computing results begins with selecting an optimization trial.

### Selecting a Current Optimization Trial

There are two ways to select the current optimization trial. Both methods set the trial so that it can be computed and results can be

accessed from the *Watershed Explorer* and the basin map as soon as they are available. The current optimization trial is shown in the title of the basin map.

The first way to select the current optimization trial is from the toolbar. The compute selection box shows all of the compute components in the project; optimization trials appear after simulations runs in the selection box. Each optimization trial in the selection box includes the prefix `Trial` followed by the name of the optimization trial. Click on the toolbar selection box and choose an optimization trial to become the current trial.

The second way to select the current optimization trial is from the *Watershed Explorer*, on the "Compute" tab. Select the optimization trial you wish to become the current trial by clicking on it in the *Watershed Explorer*. The optimization trials are listed alphabetically in the "Optimization Trials" folder.

### ***Computing an Optimization Trial***

There are three ways to compute the currently selected optimization trial. All methods automatically perform parameter checking, and if no errors are generated, proceed to the actual computing of optimization results. Additionally, the program is designed to be computationally efficient. Only components with data changes since the last compute will be recomputed; the remainder of the components have not changed so previous optimization results are still applicable. If you wish, you may force all components to be recomputed regardless of data changes since the last compute.

The first way to compute an optimization trial is from the **Compute** menu. Click on the **Compute** menu and then select the **Compute Trial** command. The name of the current optimization trial is shown in brackets as part of the menu command. If the command is not available, it is because there is no current optimization trial; you must first select a trial. A window will automatically open that shows the progress of the compute. You will need to manually close the window when the compute is done, whether it failed or was successful. If you wish to force all components to be recomputed instead of just those with data changes, hold the *control* key while selecting the menu command.

The second way to compute an optimization trial is from the *Watershed Explorer*, on the "Compute" tab. Select the optimization trial you wish to compute by clicking on it in the *Watershed Explorer* with the right mouse button. A context menu is displayed that contains several choices including compute. Click the **Compute** command. The progress window will automatically open. If you wish to force all

components to be recomputed instead of just those with data changes, hold the *control* key while selecting the right mouse menu command.

The third way to compute an optimization trial is from the toolbar. The compute button is enabled whenever there is a current trial that can be computed. If the button is not available or shows a different type of compute, you must first select an optimization trial. Press the button to compute the current optimization trial. The progress window will automatically open. If you wish to force all components to be recomputed instead of just those with data changes, hold the *control* key while selecting the toolbar button.

### **Computing Multiple Trials**

Multiple optimization trials can be computed in rapid succession. Each trial included for simulation is internally managed the same as if it were computed in isolation. The steps automatically performed for the user begin with selecting the optimization trial, checking parameters for the trial, and finally computing the simulation. This sequence is repeated in rapid succession for each optimization trial in the selected set. Appropriate feedback is provided through a progress bar.

The multiple optimization trials must exist before they can be selected for a multiple compute. Select the **Multiple Compute** command on the **Compute** menu. A manager is used to select optimization trials (Figure 308). Make selections in the list and then press the **Compute** button to begin computing the selected trials. A separate progress bar will be displayed for each optimization trial as it is computed. The progress bar may disappear automatically at the conclusion of an optimization trial depending on the configurations in the *Program Settings*. If errors are encountered while computing a trial, the progress bar will always remain visible after all selected trials have finished computing regardless of any other settings.

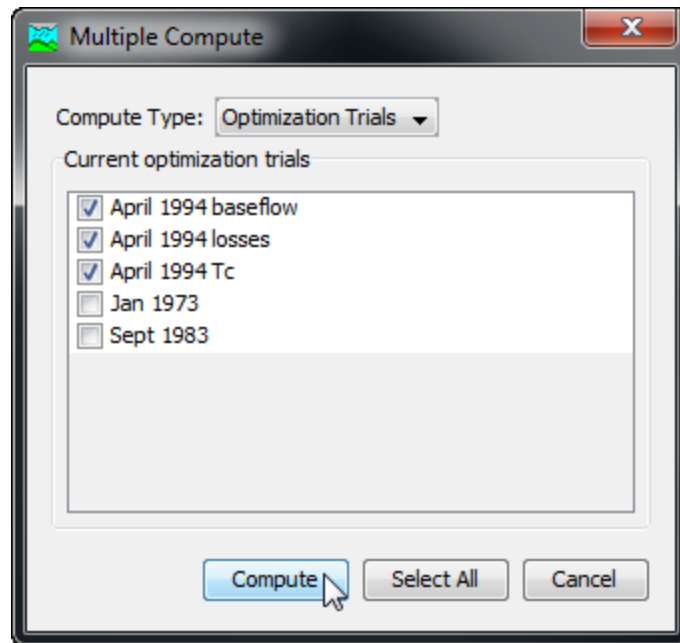

Figure 308. Selecting multiple optimization trials for sequential compute.

## Viewing Results for the Current Trial

A variety of graphical and tabular results are available after an optimization trial is computed. The same results are also available for the current trial, so long as no data used in the simulation has changed. The program tracks all of the data in the optimization trial and the selected basin model and selected meteorologic model. It also tracks any time-series data, paired data, or grid data used in the basin and meteorologic models. Results for an optimization trial can only be accessed when none of this data has changed since the last time the trial was computed. If any of the data has changed, you will need to recompute the optimization trial before you will be allowed to start accessing results.

Once a result is open for viewing it will remain open until it is closed by the user. It is possible that data used during the simulation that produced the result could change while the result is open for viewing. In this case, the open result will immediately show an indication that data has changed and the optimization trial needs to be recomputed. After the trial is recomputed the open results are automatically updated with the new results and the indication is updated with the date and time of the most-recent compute.

### Objective Function Table

The objective function table provides summary information about the objective function at the evaluation location. It includes summary information such as the basin model and meteorologic model, start

time, and end time. It indicates which objective function method was used, the start and end of the evaluation period for the function, and the final value of the function when the search method finished. It gives the volume, peak flow, time of peak flow, and time to the center of mass of the computed and observed hydrographs. Finally, it provides volume and peak flow differences between the computed and observed hydrographs. The objective function table is accessed from the **Results** menu. When the Basin Map is open and a trial is selected, choose the **Objective Function Summary** command to view the results. Sample results are shown in Figure 309.

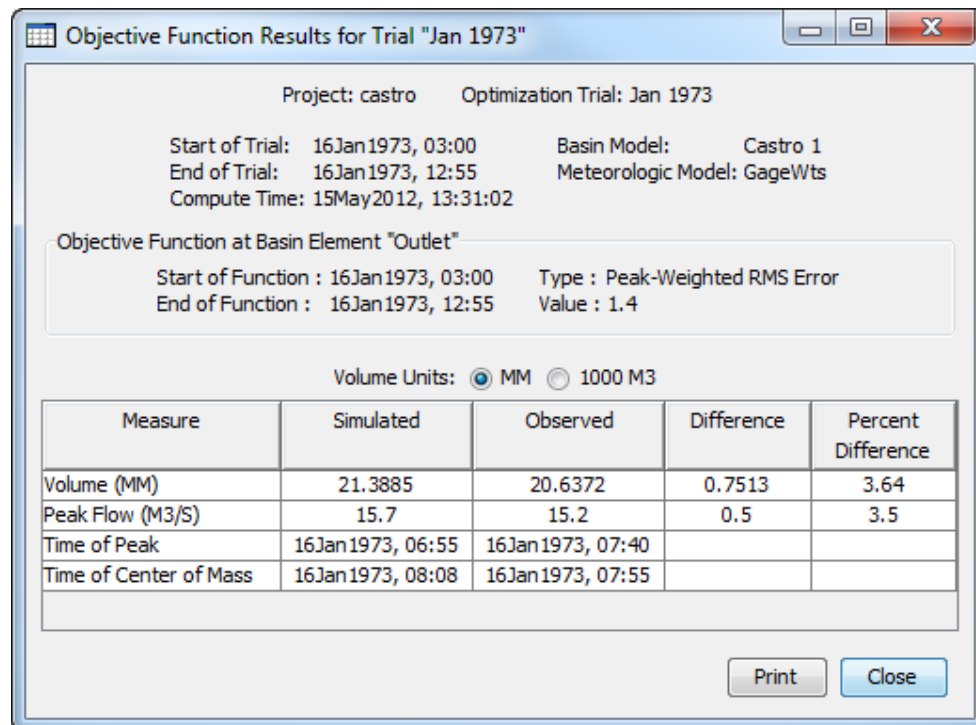
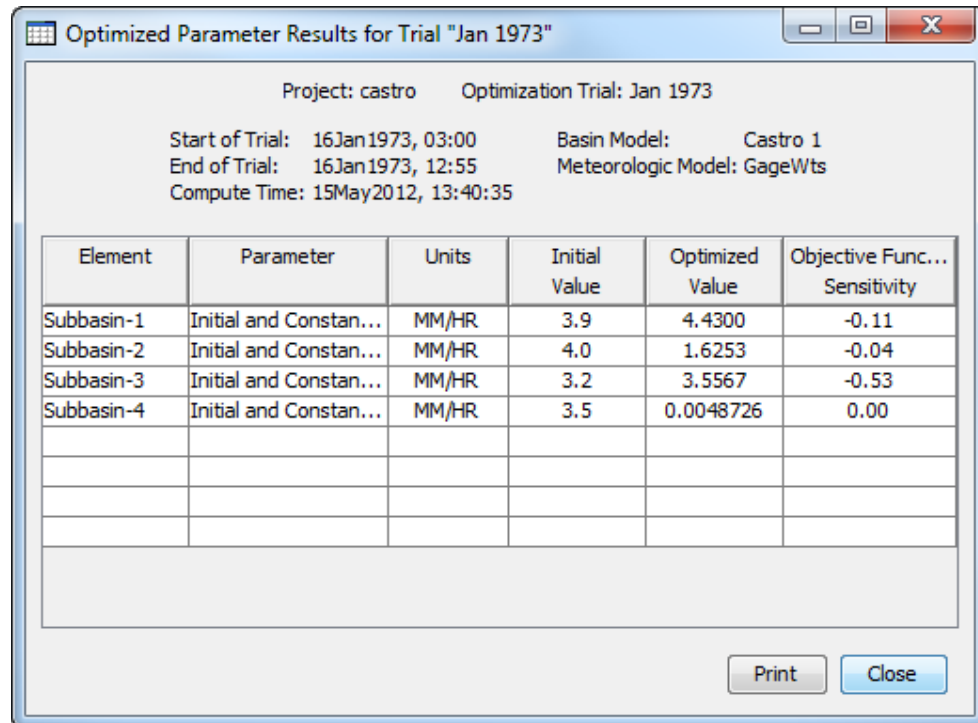

Figure 309. Objective function table for an optimization trial. The table presents statistical results of the computed and observed flow at the optimization location.

### Optimized Parameters Table

The optimized parameters table provides summary information including the basin model, meteorologic model, start time, and end time. It lists in tabular form the parameters that were selected for optimization with one row for each parameter. The table has columns for element name, parameter name, units, initial value, optimized value, and sensitivity. The sensitivity is computed after the search method has finished; it indicates the percentage change in the objective function value resulting from a one percent change in the parameter value. The optimized parameters table is accessed from the **Results** menu. When the Basin Map is open and a trial is

selected, choose the **Optimized Parameters** command to view the results. A sample set of optimized parameters is shown in Figure 310.



Project: castro Optimization Trial: Jan 1973

Start of Trial: 16Jan1973, 03:00 Basin Model: Castro 1  
 End of Trial: 16Jan1973, 12:55 Meteorologic Model: GageWts  
 Compute Time: 15May2012, 13:40:35

Element	Parameter	Units	Initial Value	Optimized Value	Objective Func... Sensitivity
Subbasin-1	Initial and Constan...	MM/HR	3.9	4.4300	-0.11
Subbasin-2	Initial and Constan...	MM/HR	4.0	1.6253	-0.04
Subbasin-3	Initial and Constan...	MM/HR	3.2	3.5567	-0.53
Subbasin-4	Initial and Constan...	MM/HR	3.5	0.0048726	0.00

Print Close

Figure 310. Optimized parameters table for an optimization trial.

### Hydrograph Comparison Graph

The hydrograph comparison graph shows the computed outflow and observed streamflow at the objective function evaluation location. This allows you to visually compare how well the computed and observed hydrographs match. Vertical lines are drawn to show the start and end of the objective function time window. The degree to which the hydrographs match helps to indicate the quality of the parameter estimation. The hydrograph comparison is accessed from the **Results** menu. When the Basin Map is open and a trial is selected, choose the **Hydrograph Comparison** command to view the results. A sample comparison graph is shown in Figure 311.

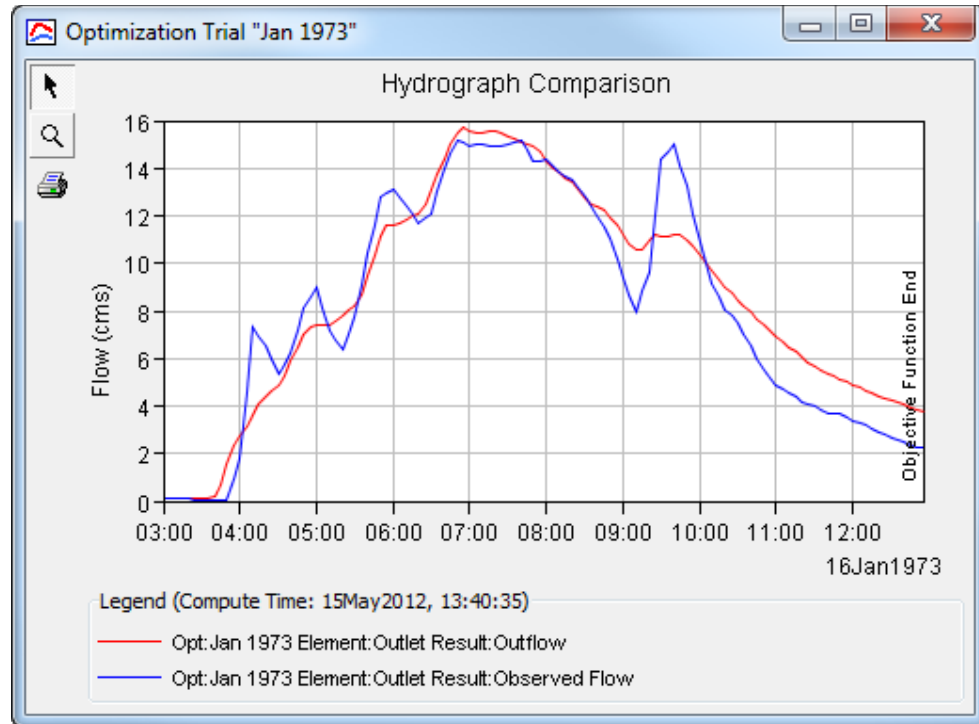

Figure 311. Hydrograph comparison graph showing the computed and observed flow at the optimization location.

### Flow Comparison Graph

The flow comparison graph shows the computed flow plotted against the observed flow. If the computed flow is exactly equal to the observed flow, then the data will plot exactly on a 45-degree line. However, in virtually all cases the match is not exact and there will be scatter in the data around the 45-degree line. Data points before the time of peak flow are shown with red circles and points after the time of peak flow are shown with blue triangles. The amount of scatter helps to indicate the quality of the parameter estimation. The flow comparison is accessed from the **Results** menu. When the Basin Map is open and a trial is selected, choose the **Flow Comparison** command to view the results. A sample flow comparison graph is shown in Figure 312.



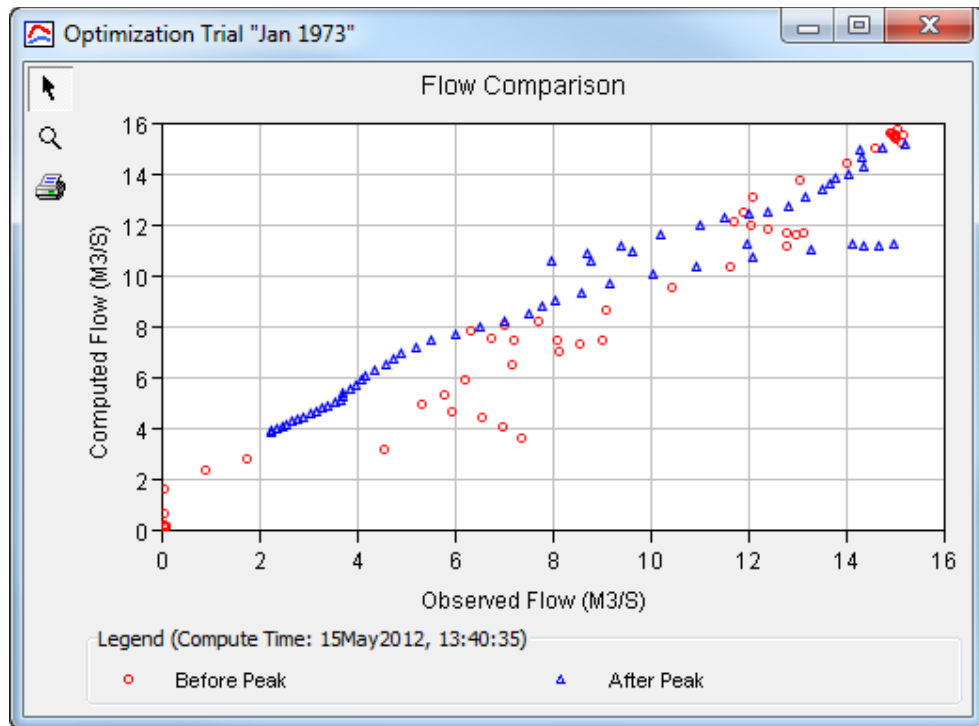

Figure 312. Flow comparison graph showing the computed flow plotted against the observed flow. Different symbols are used for points before and after the observed peak flow.

### Flow Residuals Graph

The flow residuals graph shows the difference between computed and observed flow for each time step. It is determined as the computed flow minus the observed flow and may be positive or negative. Vertical lines are drawn to show the start and end of the objective function time window. The magnitude of the residuals helps to indicate the quality of the parameter estimation. The residuals also help to indicate if there are biases in the agreement between the computed and observed flows. The flow residuals is accessed from the **Results** menu. When the Basin Map is open and a trial is selected, choose the **Flow Residuals** command to view the results. A sample residuals graphs is shown in Figure 313.

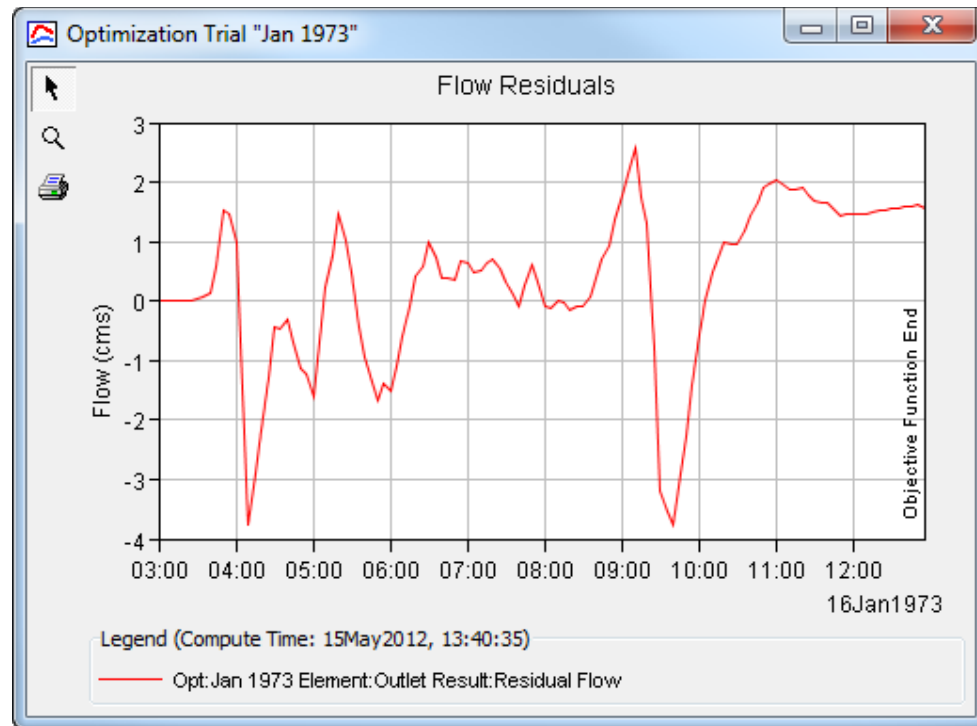

Figure 313. Flow residuals showing the computed minus the observed flow at the optimization location.

### Objective Function Graph

The objective function graph shows the value of the objective function at each iteration of the search method. The graph gives some indication of how fast the search method was able to converge to optimal parameter values. In some cases it may show that the search method was not converging at all. The objective function is accessed from the **Results** menu. When the Basin Map is open and a trial is selected, choose the **Objective Function** command to view the results. A sample objective function graph is shown in Figure 314.

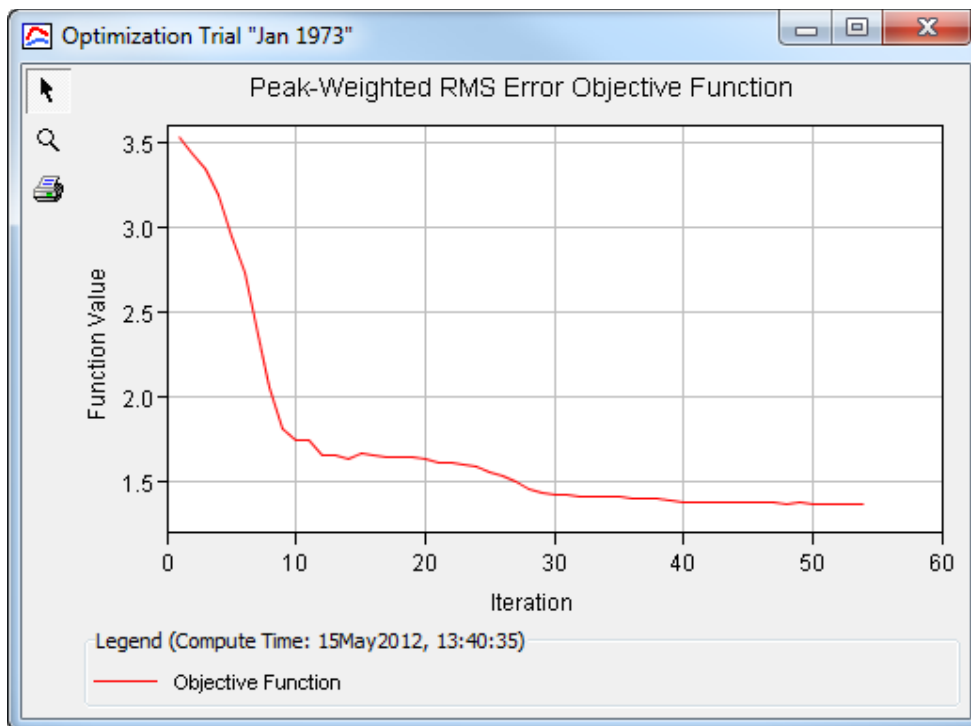

Figure 314. Objective function graph showing the value of the objective function after each iteration in the search.

### Individual Elements

There are three ways to access results for individual elements in the current optimization trial. All methods show the same results. You must select one or more elements in the basin map before you can view results for that element. However, not all elements in the basin map may have results. The optimization trial is based on a simulation run that uses a specific basin model. The optimization trial works with the elements upstream of the location where observed flow is used to evaluate the objective function. The trial does not perform simulations at any elements downstream of the element with observed flow. Therefore, results will only be available at elements upstream of the location with observed flow. Any downstream elements will have results shown as unavailable.

The first method for viewing individual element results is to use the **Results** menu. You may need to first open the basin model by clicking on it in the *Watershed Explorer*, on the "Components" tab. The current optimization trial is shown in brackets in the basin map title bar. Select one or more elements in the basin map by clicking with the arrow tool. With an element selected in the basin map, click the **Results** menu and select the **Element Graph** command, the **Element Summary Table** command, or the **Element Time-Series Table** command. The appropriate result will automatically be shown in the *Desktop* area.

The information included in the graph (Figure 315) varies by element type, but always includes outflow. Optional items such as observed flow, computed stage, and observed stage are also included.

The information included in the summary table (Figure 316) also varies by element type but always includes the peak flow, time of peak flow, and outflow volume. The time-series table (Figure 317) includes the same information as the graph but in numerical format. If you selected more than one element, then one result for each element will open. The menu commands on the **Results** menu will only be enabled if the results for the current optimization trial do not need to be recomputed, and there is an element selection in the basin map, and the selected element is upstream of the objective function evaluation element with observed flow.

The second method for viewing individual element results is to use the element icon in the basin map. Again you may need to open the basin model before attempting to view results. Click on an element to highlight it. Keep the mouse over the element and press the right mouse button. A context menu is displayed that contains several choices including **View Results**. The name of the current optimization trial is shown in brackets after the menu command. Move the mouse into the **View Results** submenu and select any of the result commands: **Graph**, **Summary Table**, or **Time-Series Table**. The appropriate result will open. If you selected more than one element, then one result for each element will open. The **View Results** menu command will only be enabled if the results for the current optimization trial do not need to be recomputed, and the selected element is upstream of the objective function evaluation element with observed flow.

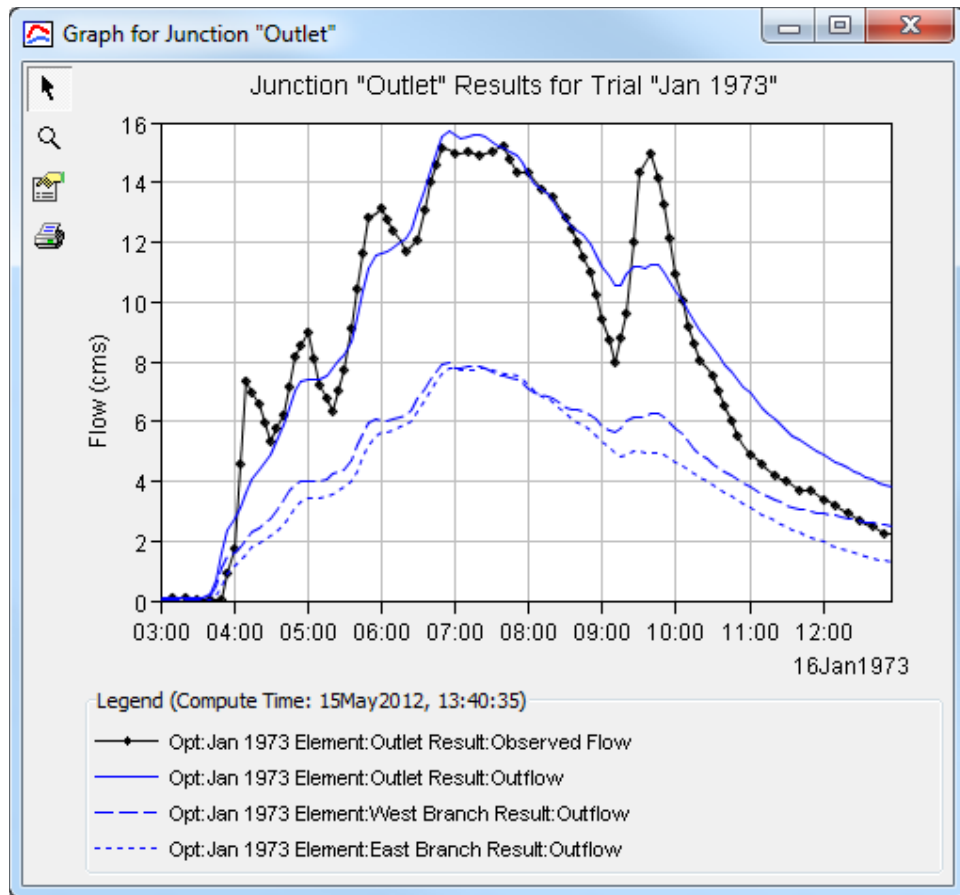

Figure 315. Element graph for a subbasin after an optimization trial.

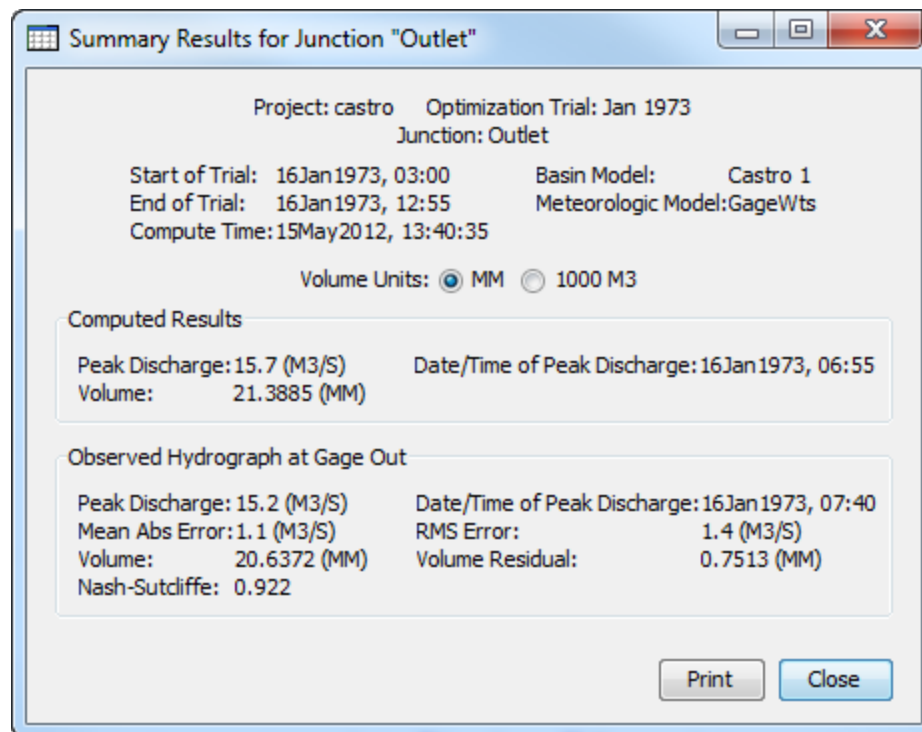

Figure 316. Element summary table for a subbasin after an optimization trial.

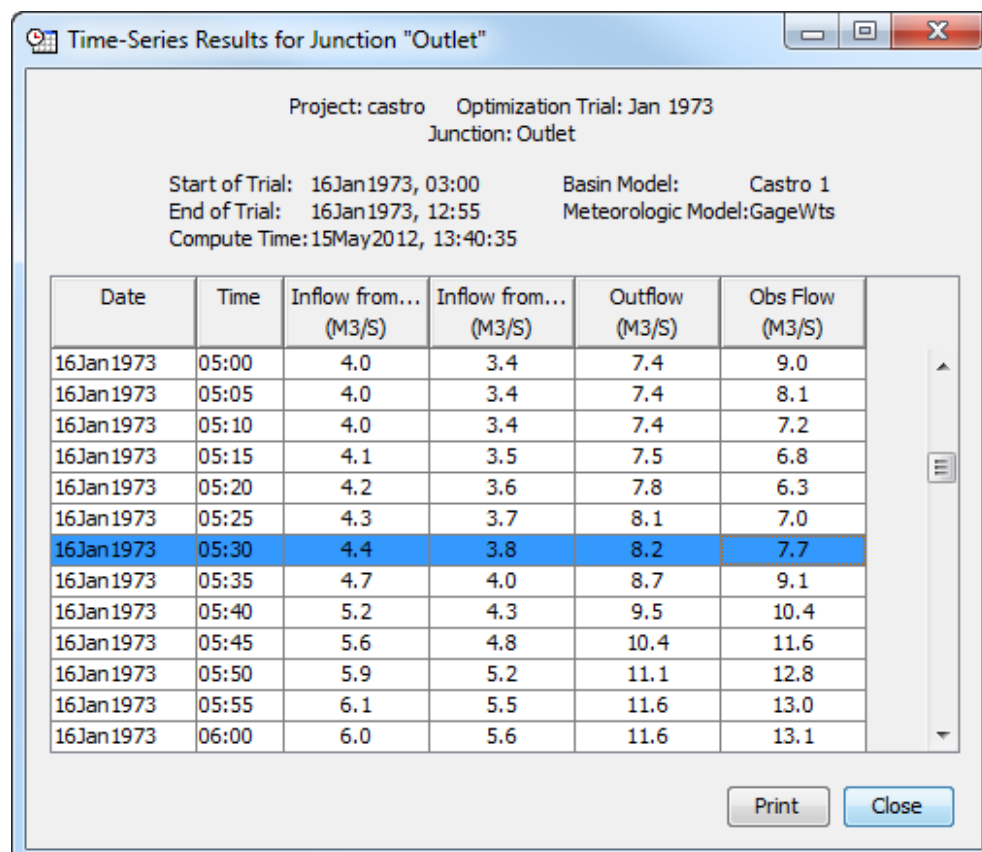

Figure 317. Element time-series table for a subbasin after an optimization trial.

The third method for viewing individual element results is to use the buttons on the toolbar. First you must open the basin model and select one or more elements in the basin map by clicking with the arrow tool. Once you have a selected element, click the graph, summary table, or time-series table buttons. The button for selecting a graph shows a line plot. The button for the summary table shows a plain table. The button for the time-series table shows a table plus a clock. The appropriate result will automatically open. If you selected more than one element, then one result for each element will be added to the *Desktop*. The toolbar buttons for viewing element results will only be enabled if the results for the current optimization trial do not need to be recomputed, and there is an element selection in the basin map, and the selected element is upstream of the objective function evaluation element with observed flow.

## **Viewing Results for Other Trials**

In addition to viewing results for the currently selected optimization trial, it is also possible to view results for other trials that are not the current selection. However, those other trials are also tracked in the same way as the current trial to make sure data has not changed and results do not need to be recomputed. If any of the data in an optimization trial changes, it will have to be recomputed before results can be viewed. Results for other optimization trials are accessed from the *Watershed Explorer*, on the "Results" tab.

To begin viewing results, go to the "Results" tab of the *Watershed Explorer* and click on the desired optimization trial icon. If necessary, click on the "Optimization Trials" folder to expand it and view the optimization trials in the project. The optimization trial icon will be disabled if any data used in the trial has changed and results need to be recomputed. If any result is open at the time data changes, the affected results will be automatically updated.

### **Trial Results**

The objective function summary can be accessed by clicking on the "Objective Function Summary" node in the *Watershed Explorer* (Figure 318). The table will be displayed. It is exactly the same table that can be viewed for the current optimization trial. Similarly, the other results for optimized parameters, hydrograph comparison, flow comparison, flow residuals, and objective function can also be accessed in the same way.

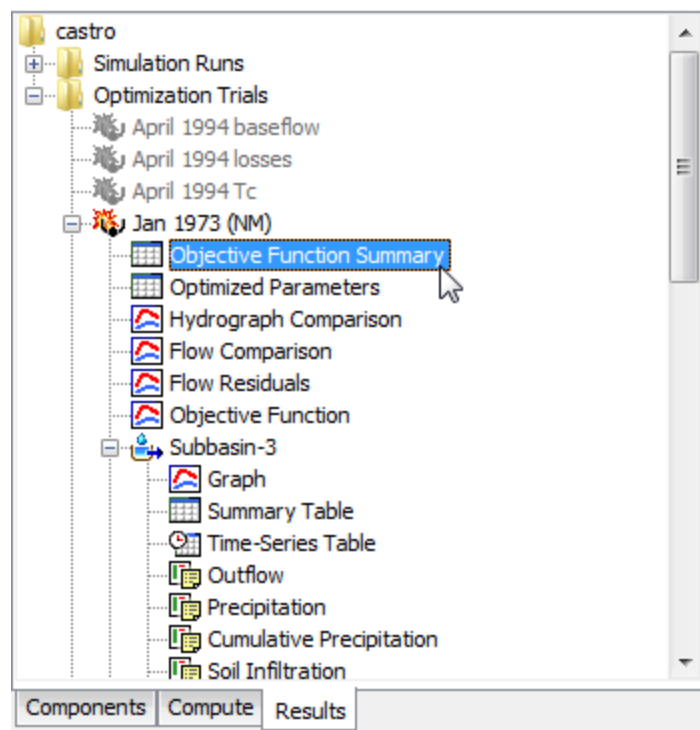

Figure 318. Viewing optimization results in the Watershed Explorer. The results for each element upstream of the optimization location are also shown in addition to trial results.

### Individual Elements

Each element above the objective function evaluation location is shown in the *Watershed Explorer* under the optimization trial node. These elements are listed in hydrologic order after the objective function graph. The results for each element are accessed by clicking on its node. The first item listed for each element is the graph; click on the "Graph" node to view the result (Figure 318). It is exactly the same graph that can be viewed for the current optimization trial. The information included in the graph varies by element type but always includes outflow. Optional items such as observed flow, computed stage, and observed stage are also included. Similarly, the summary table and time-series table can also be accessed by clicking on the "Summary Table" or "Time-Series Table" node, respectively.

### Element Time-Series Preview Graph

All of the time-series data computed by an individual element are available for viewing. The time-series data are listed under each element node in the *Watershed Explorer*. The first node under each element is the graph, followed by the summary table and time-series table. The remaining nodes for each element represent the different time-series data. Click on a time-series node to preview the data in the



*Component Editor.* You may select multiple time-series data by holding the shift or control key while using the mouse to click on additional nodes (Figure 319). The selected time-series may come from different elements in the same optimization trial, the same element in different trials, or different elements in different trials. Results can also be combined from both simulation runs and optimization trials. The selected time-series data will automatically be partitioned into groups by data type.

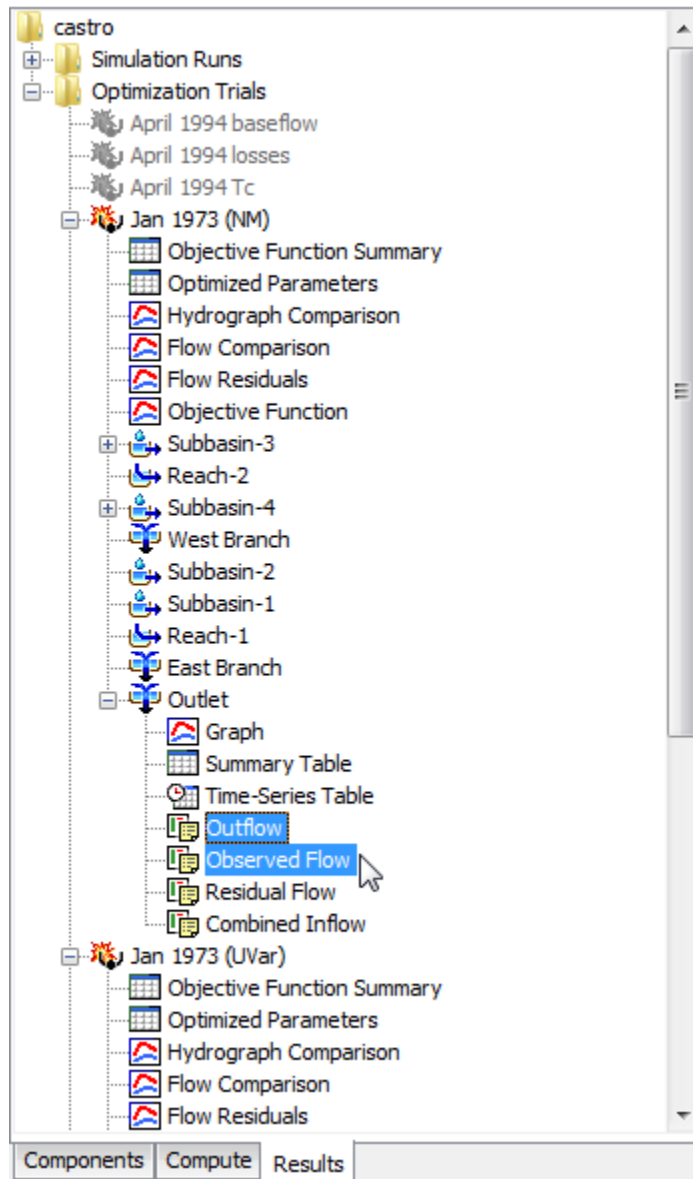

Figure 319. Viewing optimization trial results in the Watershed Explorer. Two results were selected in the same element in one trial; results could have been combined from multiple elements or trials.

## Time-Series Tables and Graphs

Preview graphs of selected time-series data can be opened as graphs or time-series tables within the *Desktop* area. Begin by selecting the time-series you wish to include in the graph or table. Once you have selected the desired time-series, you can press the graph or time-series table buttons on the toolbar. The chosen time-series will be graphed or tabulated (Figure 320).

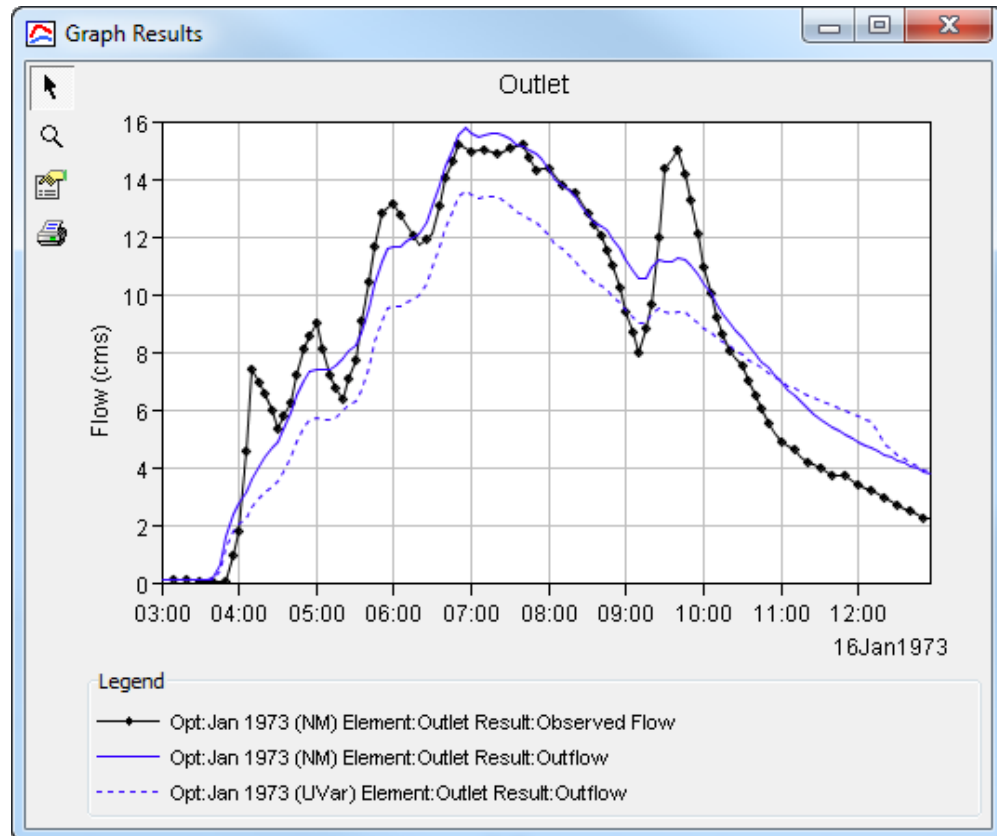

Figure 320. Comparing results from two different optimization trials to determine which one might be a better fit to the observed flow.

After you have opened a time-series table or graph, you may add additional time-series results. Position the mouse over the time-series result you wish to add to the graph or table. Press and hold the left mouse button and then drag the mouse over the top of the graph or table where you want the result to be added. The mouse cursor will change to indicate which tables and graphs can accept the additional time-series. Release the mouse button while it is over the desired table or graph and it will be automatically updated to show the additional time-series results.

## **Changing Graph Properties**

All of the graphs open with default properties for line color, line style, data symbols, etc. These default properties have been selected to be appropriate for most situations. However, it is possible to customize the properties in a graph. To change the properties, first click on the graph to select it. Next go to the **Results** menu and select the **Graph Properties...** command. An editor will open that can be used to change the properties of the selected graph. The properties for each time-series curve can be changed. It is also possible to change the properties for the axis, title, gridlines, patterns, and legend. The editor used to change properties is the same as used for simulation run graphs shown in Figure 294.

This Page Left Blank

---

## CHAPTER 14

# ***Forecasting Streamflow***

Streamflow forecasts are fundamental to effective operation of flood control reservoirs and levee systems. Forecasts may also support emergency operations by providing estimates of the timing and extent of expected hazardous or damaging flood conditions. Forecasts are based on recent meteorologic and hydrologic conditions in the watershed, and may also incorporate predicted future meteorologic conditions. Although most often used to predict anticipated flood conditions, streamflow forecasts may also support water supply, hydropower, environmental flow requirements, and other operational needs.

### ***Forecast Alternatives***

Streamflow forecasting typically includes simulation of past and future conditions. The process begins with the selection of a time of forecast. Typically the time of forecast represents the last available time for meteorologic observations of precipitation, temperature, and other variables. If observations of streamflow, stage, or reservoir pool elevation are available, the last available value is also generally near the time of forecast. The simulation is started hours or days before the time of forecast. Results computed between the start time and the forecast time may be called the "look back period." When observations of current watershed conditions are available, they may be compared with computed results from the look back period to make calibration adjustments that improve model performance. Meteorologic observations are not available after the time of forecast and predictions of future values are used. For example, a quantitative precipitation forecast (QPF) provides a meteorologic prediction of future precipitation depths. Similar predictions are used for other meteorologic variables such as temperature. The future streamflow response is simulated based on the predicted meteorologic conditions. This period of time in the future may be called the "forecast."

Time is often of the essence when performing streamflow forecasting and modeling techniques must consider this fact. During the development of a forecast it is common to group similar subbasins together and apply parameter adjustments across each group. This is supported in forecast alternatives through the use of zones. Creating zones is described in [Chapter 6](#). Zones are used in a forecast alternative to quickly set parameter adjustments when a group of

subbasins have similar conditions. A parameter adjustment is entered once and applied to all of the subbasins in the zone. A local element override can be used if a subbasin within a zone diverges in behavior from the rest of the subbasins in that same zone.

Forecast alternatives are one of the components that can compute results. Each alternative is composed of a basin model, meteorologic model, and time control information. The alternative also includes zone configurations for loss rate, transform, and baseflow parameters. The alternative may optionally include blending at elements with observed flow. Results are available at each element after the simulation is complete.

A forecast alternative is constructed using the same initial conditions and parameters found in the basin model selected in the forecast alternative. Then the parameter adjustments specified for each zone replace the values taken from the basin model, with each subbasin or reach in the zone receiving the same parameter adjustment. Any local element overrides are applied after zone adjustments. Initial baseflow may then be set using observed flow and reservoir pool elevations set using observed stage. Next, results are computed using the adjusted parameter values and the selected meteorologic model. Finally the computed results are adjusted at elements with observed flow and where blending has been selected.

It is often necessary to prepare multiple forecasts with the same time of forecast. The multiple forecasts provide alternative estimates of future conditions under different scenarios or assumptions. For example, multiple alternatives could be used to explore the effect of different assumptions about the soil moisture state of the watershed at the beginning of the look back period. In another example, several alternatives could be used to explore the range of potential future flows depending on the amount of future precipitation. One more example would be the development of multiple alternatives with different reservoir release schedules in order to evaluate the impact of releases on downstream flows. Results from all considered alternatives can be used as part of a decision support system to determine how reservoirs should be operated, or to issue emergency flood warnings.

### ***Creating a New Forecast Alternative***

A new forecast alternative is created using a wizard that helps you navigate the steps to creating a new alternative. There are two ways to access the wizard. The first way to access the wizard is to click on the **Compute** menu and select the **Create Compute ⇒ Forecast Alternative** command; it is only enabled if at least one basin model and meteorologic model exist. The wizard will open and begin the process of creating a new forecast alternative. The second way to

access the wizard is from the *Forecast Alternative Manager*. Click on the **Compute** menu and select the **Forecast Alternative Manager** command. The *Forecast Alternative Manager* will open and show any alternatives that already exist. Press the **New...** button to access the wizard and begin the process of creating a forecast alternative, as shown in Figure 321.

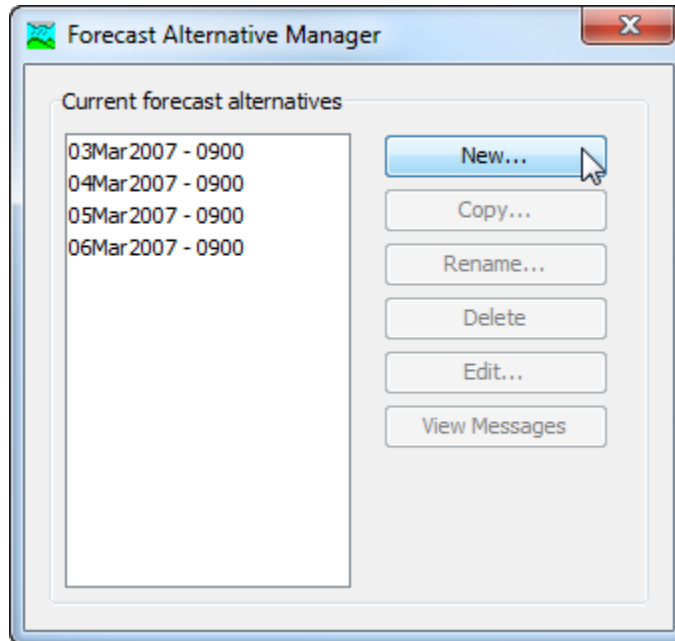

Figure 321. Beginning the process of creating a new forecast alternative using the *Forecast Alternative Manager*.

The first step of creating a forecast alternative is to provide the name for the new alternative (Figure 322). A default name is provided for the new forecast alternative; you can use the default or replace it with your own choice. After you finish creating the alternative you can add a description to it. If you change your mind and do not want to create a new forecast alternative, you can press the **Cancel** button at the bottom of the wizard or the **X** button in the upper right corner of the wizard. The **Cancel** button can be pressed at any time you are using the wizard. Press the **Next>** button when you are satisfied with the name you have entered and are ready to proceed to the next step.

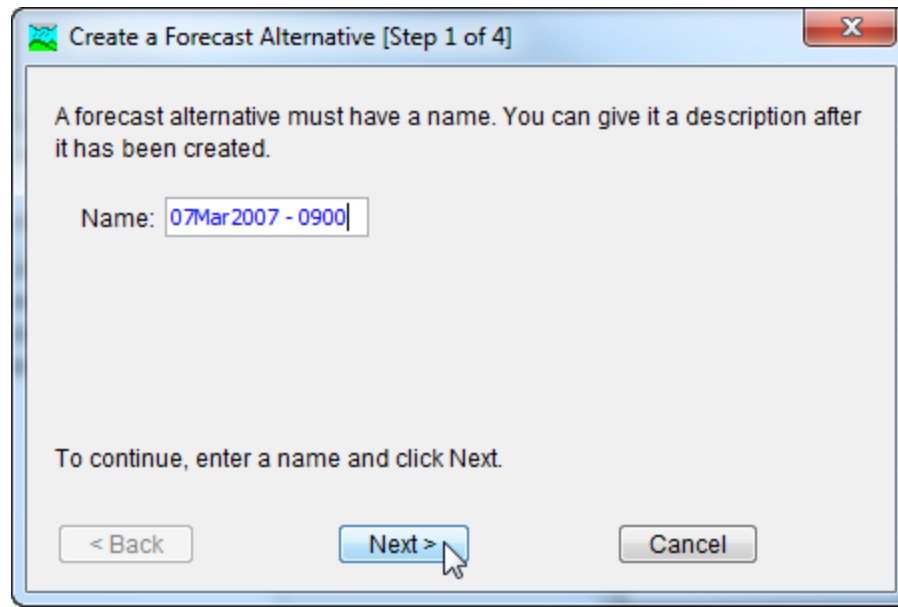

Figure 322. Entering a name for a new forecast alternative. The remaining steps are to select a basin model, select a meteorologic model, and select a time interval and zone configurations.

The second step of creating a forecast alternative is to select a basin model. All of the basin models that are currently part of the project are displayed in alphabetical order. By default the first basin model in the table is selected. The selected basin model is highlighted. You can use your mouse to select a different basin model by clicking on it in the table of available choices. You can also use the arrow keys on your keyboard to select a different basin model. Press the **Next>** button when you are satisfied with the basin model you have selected and are ready to proceed to the next step. Press the **<Back** button if you wish to return to the previous step and change the name for the new forecast alternative.

The third step of creating a forecast alternative is to select a meteorologic model. All of the meteorologic models that are currently part of the project are displayed in alphabetical order. By default the first meteorologic model in the table is selected. The selected meteorologic model is highlighted. You can use your mouse to select a different meteorologic model by clicking on it in the table of available choices. You can also use the arrow keys on your keyboard to select a different meteorologic model. You are responsible for selecting a basin model in step two and a meteorologic model in this step that will successfully combine to compute results. Press the **Next>** button when you are satisfied with the meteorologic model you have selected and are ready to proceed to the next step. Press the **<Back** button if you wish to return to the previous step and select a different basin model for the forecast alternative.



The fourth step of creating a forecast alternative is to select a time interval and zone configurations. The time interval must be selected from among the available choices. The default selection is 15 minutes, but you may choose any of the available intervals. You may also select the zone configuration to use for loss rate adjustments, transform adjustments, baseflow adjustments, and routing adjustments. The selection list includes all of the zone configurations available in the basin model that was selected in step two. You may use a different zone configuration for each type of adjustment. Alternately you may use the same zone configuration for loss rate, transform, baseflow, and routing adjustments. Press the **Finish** button when you are satisfied with the name you have entered, the basin model and meteorologic model you selected, and are ready to create the forecast alternative. Press the **<Back** button if you wish to return to the previous step and select a different meteorologic model.

### ***Copying a Forecast Alternative***

There are two ways to copy a forecast alternative. Both methods for copying a trial create an exact duplicate with a different name. Once the copy has been made it is independent of the original and they do not interact.

The first way to create a copy is to use the *Forecast Alternative Manager*, which is accessed from the **Compute** menu. Select the forecast alternative you wish to copy by clicking on it in the list of current forecast alternatives. The selected alternative is highlighted after you select it. After you select an alternative you can press the **Copy...** button on the right side of the window. The *Copy Forecast Alternative* window (Figure 323) will open where you can name and describe the copy that will be created. A default name is provided for the copy; you can use the default or replace it with your own choice. A description can also be entered; if it is long you can use the button to the right of the description field to open an editor. When you are satisfied with the name and description, press the **Copy** button to finish the process of copying the selected forecast alternative. You cannot press the **Copy** button if no name is specified. If you change your mind and do not want to copy the selected forecast alternative, press the **Cancel** button or the **X** button in the upper right to return to the *Forecast Alternative Manager* window.

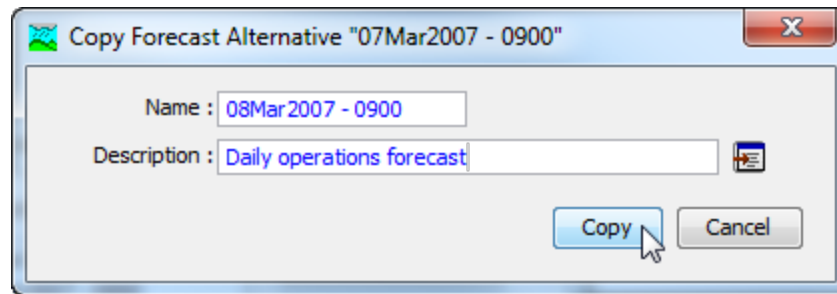

Figure 323. Creating a copy of a forecast alternative.

The second way to copy is from the "Compute" tab of the *Watershed Explorer*. Move the mouse over the forecast alternative you wish to copy and press the right mouse button (Figure 324). A context menu is displayed that contains several choices including copy. Click the **Create Copy...** command. The *Copy Forecast Alternative* window will open where you can name and describe the copy that will be created. A default name is provided for the copy; you can use the default or replace it with your own choice. A description can also be entered; if it is long you can use the button to the right of the description field to open an editor. When you are satisfied with the name and description, press the **Copy** button to finish the process of copying the selected forecast alternative. You cannot press the **Copy** button if no name is specified. If you change your mind and do not want to copy the selected forecast alternative, press the **Cancel** button or the **X** button in the upper right of the *Copy Forecast Alternative* window to return to the *Watershed Explorer*.

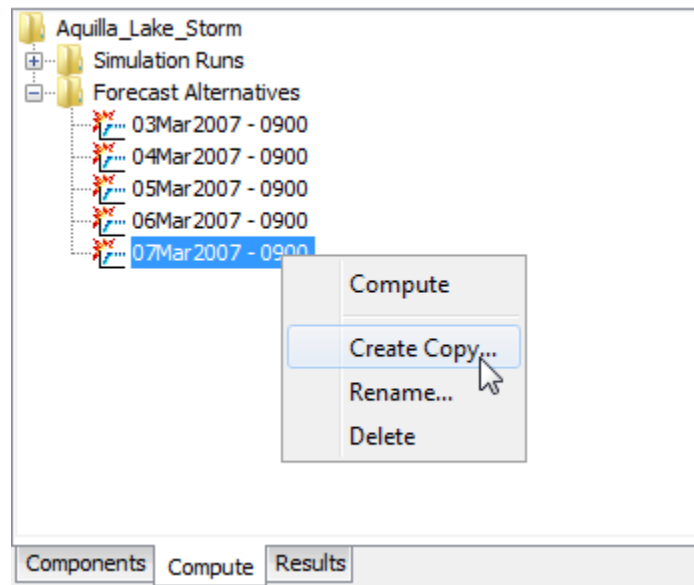

Figure 324. Copying a forecast alternative from the *Watershed Explorer*. The *Copy Forecast Alternative* window will appear after the **Create Copy...** menu command is selected.

## Renaming a Forecast Alternative

There are two ways to rename a forecast alternative. Both methods for renaming an alternative change its name and perform other necessary operations.

The first way to perform a rename is to use the *Forecast Alternative Manager*, which you can access from the **Compute** menu. Select the forecast alternative you wish to rename by clicking on it in the list of current alternatives. The selected alternative is highlighted after you select it. After you select an alternative you can press the **Rename...** button on the right side of the window. The *Rename Forecast Alternative* window (Figure 325) will open where you can provide the new name. If you wish you can also change the description at the same time. If the new description will be long, you can use the button to the right of the description field to open an editor. When you are satisfied with the name and description, press the **Rename** button to finish the process of renaming the selected forecast alternative. You cannot press the **Rename** button if no name is specified. If you change your mind and do not want to rename the selected forecast alternative, press the **Cancel** button or the **X** button in the upper right of the *Rename Forecast Alternative* window to return to the *Forecast Alternative Manager* window.

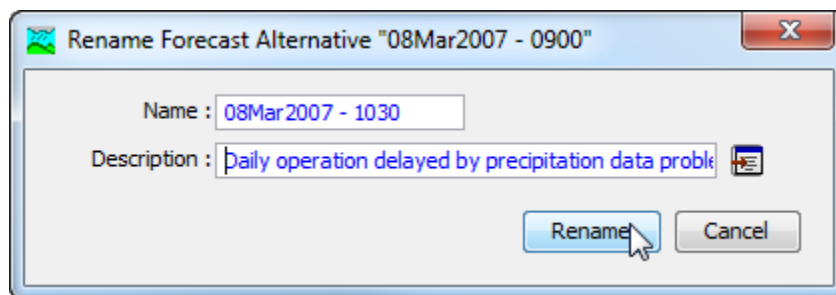

Figure 325. Renaming a forecast alternative. This was accessed from the *Forecast Alternative Manager*.

The second way to rename is from the "Compute" tab of the *Watershed Explorer*. Select the forecast alternative you wish to rename by clicking on it in the *Watershed Explorer*; it will become highlighted. Keep the mouse over the selected alternative and click the left mouse button again. The highlighted name will change to editing mode (Figure 326). You can then move the cursor with the arrow keys on the keyboard or by clicking with the mouse. You can also use the mouse to select some or all of the name. Change the name by typing with the keyboard. When you have finished changing the name, press the **Enter** key to finalize your choice. You can also finalize your choice by clicking elsewhere on the "Compute" tab. If you

change your mind while in editing mode and do not want to rename the selected forecast alternative, press the **Escape** key.

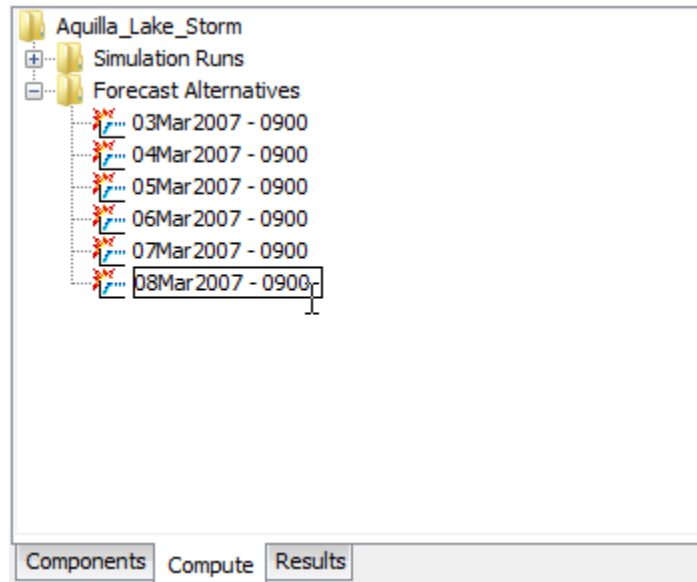

Figure 326. Renaming a forecast alternative in the Watershed Explorer.

### **Deleting a Forecast Alternative**

There are two ways to delete a forecast alternative. Both methods for deleting an alternative remove it from the project and automatically delete previously computed results. Once an alternative has been deleted it cannot be retrieved or undeleted.

The first way to perform a deletion is to use the *Forecast Alternative Manager*, which you can access from the **Compute** menu. Select the forecast alternative you wish to delete by clicking on it in the list of current alternatives. The selected alternative is highlighted after you select it. After you select an alternative you can press the **Delete** button on the right side of the window. A window will open where you must confirm that you wish to delete the selected alternative as shown in Figure 327. Press the **OK** button to delete the alternative. If you change your mind and do not want to delete the selected forecast alternative, press the **Cancel** button or the **X** button in the upper right to return to the *Forecast Alternative Manager* window.

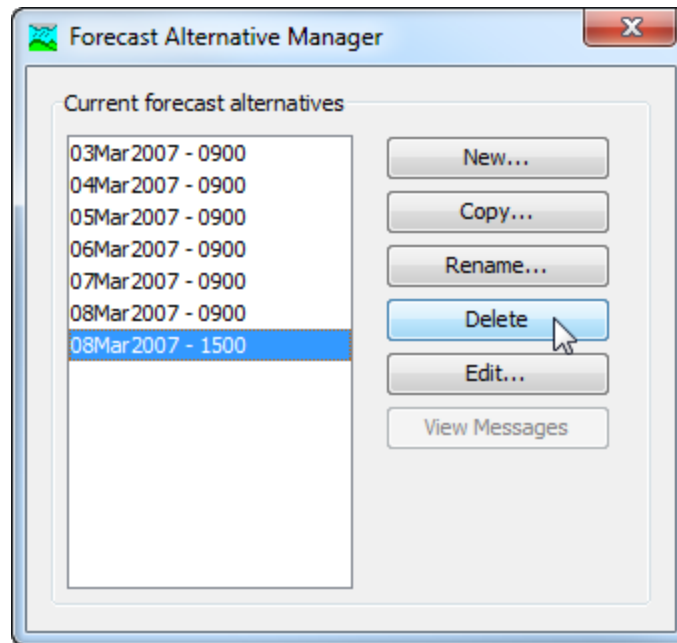

Figure 327. Preparing to delete a forecast alternative from the Forecast Alternative Manager. A confirmation will be required after pressing the **Delete** button.

The second way to delete is from the "Compute" tab of the *Watershed Explorer*. Select the forecast alternative you wish to delete by clicking on it in the *Watershed Explorer*; it will become highlighted (Figure 328). Keep the mouse over the selected alternative and click the right mouse button. A context menu is displayed that contains several choices including delete. Click the **Delete** command. A window will open where you must confirm that you wish to delete the selected alternative. Press the **OK** button to delete the alternative. If you change your mind and do not want to delete the selected forecast alternative, press the **Cancel** button or the **X** button in the upper right to return to the *Watershed Explorer*.

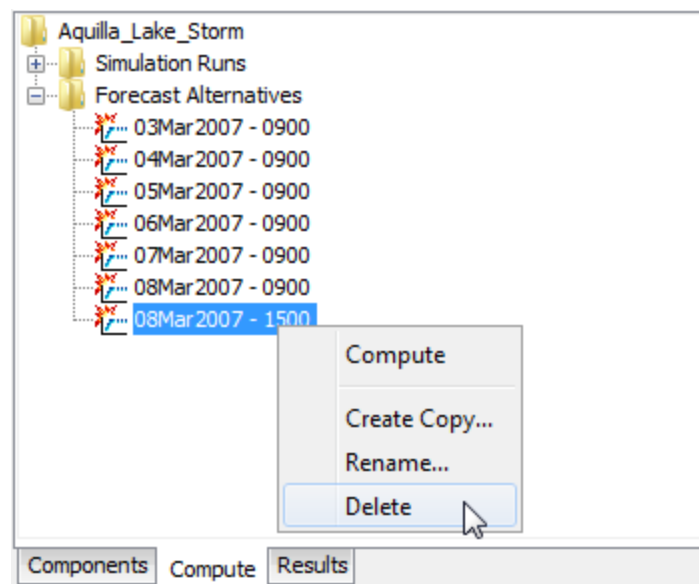

Figure 328. Deleting a forecast alternative in the Watershed Explorer.

### Selecting Components

One of the principal tasks when creating a forecast alternative using the wizard is the selection of the components that will be used to compute forecast results. The components include the basin model and the meteorologic model. These components are selected when creating a new forecast alternative with the wizard. However, you can change the basin model and meteorologic model you wish to use at any time using the *Component Editor* for the forecast alternative. Access the *Component Editor* from the "Compute" tab of the *Watershed Explorer* (Figure 329). If necessary, click on the "Forecast Alternatives" folder to expand it and view the available forecast alternatives. The *Component Editor* contains a basin model selection list that includes all of the basin models in the project. The *Component Editor* also contains a meteorologic model selection list that includes all of the meteorologic models in the project.

**Name: 08Mar2007 - 0900**

Description:

DSS File: C:\Users\j0hecwas\Document

Basin Model: Aquilla Lake

Meteorologic Model: NexRad Weather Radar

\*Start Date (ddMMYYYY) 04Mar2007

\*Start Time (HH:mm) 09:00

\*Forecast Date (ddMMYYYY) 08Mar2007

\*Forecast Time (HH:mm) 09:00

\*End Date (ddMMYYYY) 10Mar2007

\*End Time (HH:mm) 09:00

Time Interval: 15 Minutes

Loss Rate Config: Main Tributaries

Transform Config: Main Tributaries

Baseflow Config: Main Tributaries

Routing Config: Tributaries

Figure 329. The forecast alternative component editor can be used to change the selected components, time window, and zone configurations.

### Entering a Time Window

You must enter a start date and time, a forecast date and time, and an end date and time for the forecast alternative. The time control information is not specified in the wizard used to create the forecast alternative. The time control information must be entered after the alternative is created using the *Component Editor* for the forecast alternative (Figure 329). Enter the start date using the indicated format for numeric day, abbreviated month, and four-digit year. Enter the forecast date and end date using the same format. The start time, forecast time, and end time are entered using 24-hour time format.

### Selecting Zone Configurations

Zone configurations are used to make parameter adjustments in a forecast alternative. A zone configuration is defined in the basin model and the basin model may contain more than one zone configuration. Each zone configuration contains either subbasin or reach elements but not both types of elements. In turn, each zone configuration contains one or more zones. All of the subbasins or reaches in the basin model should be assigned to a zone. The zone configuration is

selected using the *Component Editor* for the forecast alternative (Figure 329). A zone configuration can be selected for setting the lossrate adjustments, the transform adjustments, the baseflow adjustments, and the routing adjustments. A different zone configuration may be used for each selection, or the same zone configuration may be used more than once. No parameter adjustments can be performed until zone configuration selections are made.

## **Adjusting Parameters for the Forecast**

The subbasins and reaches in a forecast alternative are initialized to default values using the parameter values from the basin model. The parameter values in the elements may be adjusted for the forecast without altering the original parameter values in the basin model. It is not required to make parameter adjustments. When no parameter adjustments are made, the values taken from the basin model are used without modification for the forecast. However, most forecasts will include parameter adjustments to reflect current conditions in the watershed due to recent meteorologic conditions.

### **Zone Parameter Adjustments**

Adjustments are entered using the parameter editors for the forecast alternative. The editors are accessed on the **Compute** menu by using the **Forecast Parameter Adjustments** command. Be sure to select a current forecast alternative in order to access the editors. A separate parameter editor is shown for each loss rate, transform, baseflow, and routing method used in the basin model. Adjustments are set for each zone using the upper half of the parameter editor (Figure 330). The upper half of the editor includes one row for each zone. Without zone adjustments, element results are calculated purely from the basin model parameters.

Two columns are included for each editable parameter in the loss rate, transform, baseflow, or routing method. The first column labeled *Zone Average* shows the area-weighted average default parameter value computed over all elements in the zone. A parameter adjustment can be entered in the second column labeled *Adjustment*. If the adjustment is left blank, then the default parameter value will be used for each element. You may add a fixed value to the parameter in all elements within the zone. For example, entering an adjustment of +0.2 would increase the parameter value by "0.2" at each element in the zone. You may subtract a fixed value from the parameter in all elements within the zone. For example, entering -2.1 would decrease the parameter value by "2.1" at each element in the zone. You may multiply the parameter at each element within the zone by a



fixed value. For example, entering an adjustment of  $*0.8$  would multiply the parameter value by "0.8" at each element in the zone. Finally, you may replace the default parameter value at each element within the zone by a fixed value. For example, entering an adjustment of  $7.0$  would set the parameter value to "7.0" at each element in the zone. Press the **Apply** button when you have finished entering zone parameter adjustments.

Zone	Initial Deficit (IN) Zone Average	Initial Deficit (IN) Adjustment	Maximum Deficit (IN) Zone Average	Maximum Deficit (IN) Adjustment
Bardwell/ChambersCreek	0.6	+0.2	10	-2.1
Benbrook/Clear Fork	1.31	*0.8	10	7.0
Bridgeport				
Cedar Creek				

Override	Zone Subbasins	Initial Deficit (IN) Base Value	Initial Deficit (IN) Final Value	Maximum Deficit (IN) Base Value	Maximum Deficit (IN) Final Value
<input type="checkbox"/>	Lk_Weatherford_S010	1.25	1.06	10	7.1
<input type="checkbox"/>	Lk_Weatherford_S020	1.25	1.06	10	7.1
<input type="checkbox"/>	Clear_Fork_S010	1.5	1.27	10	7.1
<input type="checkbox"/>	Bear_Ck_S010	1.25	1.06	10	7.1

*Figure 330. Entering parameter adjustments for the Alligator Creek zone. The initial deficit will be decreased by 5 mm at each subbasin, the maximum deficit will be multiplied by 1.25 at each subbasin, and the constant rate will be increased by 2 mm/hr at each subbasin.*

The bottom half of the parameter editor (Figure 330) shows details about the parameter values for the elements in the selected zone. Clicking on a row in the upper half of the parameter editor selects a zone. The lower half of the editor will show one row for each element in the selected zone. Two columns are shown for each parameter in the loss rate, transform, baseflow, or routing method. The first column labeled *Base Value* shows the default parameter value taken from the basin model. The second column labeled *Final Value* shows the adjusted parameter value that will be used during the forecast. Adjusted parameter values are calculated using any zone adjustments entered in the upper half of the editor. The adjusted parameter values are updated everytime the **Apply** button is pressed.

### ***Element Parameter Overrides***

Zone parameter adjustments provide a quick method for changing subbasin and reach parameters to produce a forecast. However,

sometimes one or more elements within a zone need a different adjustment than the rest of the elements in that same zone. An element override may optionally be specified to use different parameter values at an individual subbasin or reach within a zone. Without element overrides, element results are calculated purely from the basin model parameters and zone adjustments.

To begin, you must enable the override for the desired element (Figure 331). Within the upper half of the parameter editor, click on the row for the zone where the element is located. That zone will become the current zone and the elements within the zone will be shown in the lower half of the parameter editor. Next, click on the *Override* checkbox located in the lower half of the editor next to the element name. Once the override is enabled, the *Final Value* column for each parameter will be editable for the selected element. The default final value for each parameter is computed automatically by applying the zone adjustment, if any, to the default value found in the basin model. During an override operation, the final value of a parameter can be changed. You may choose to override only one parameter in the loss rate, transform, baseflow, or routing method. Alternately, you may choose to override several parameters or all parameters. Any override adjustments are removed when the checkbox for the element is cleared.

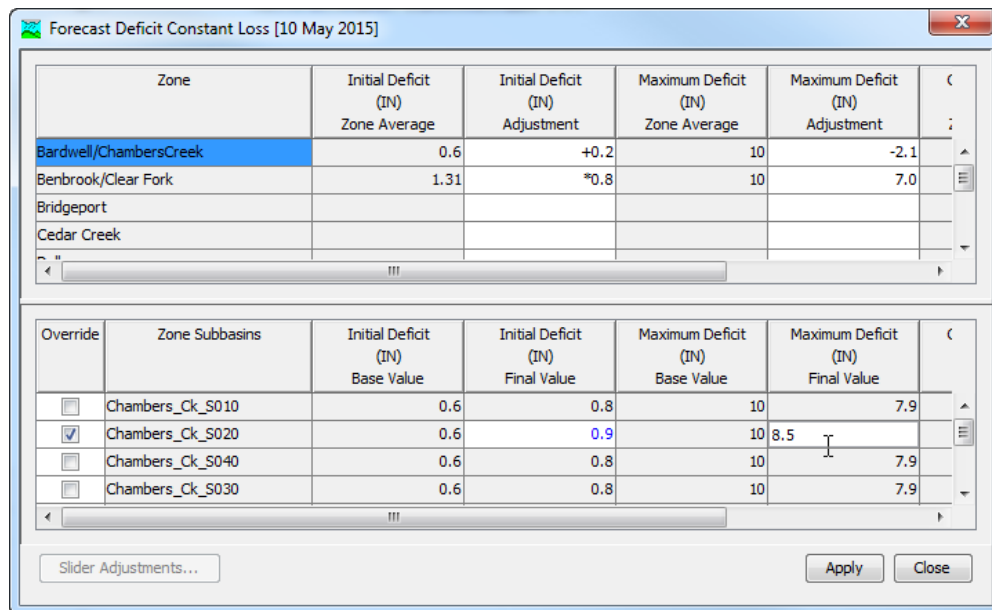

Figure 331. Entering an override for the AlgCr-02 subbasin within the Alligator Creek zone. The default final value has been changed for the Initial Deficit parameter.

## Slider Adjustments

A slider adjustment is an alternate way to view and change a zone parameter adjustment or an element parameter override. An example of a slider adjustment is shown in Figure 332. Instead of typing a new value for the adjustment in a data entry table, the slider can be moved with the mouse to quickly obtain a new factor. Slider adjustments enhance existing zone parameter adjustments and element parameter overrides. Configuration information is required for each adjustment or override that will be manipulated with a slider. Preparing to use a slider adjustment begins with selecting the adjustments or override and entering configuration information.

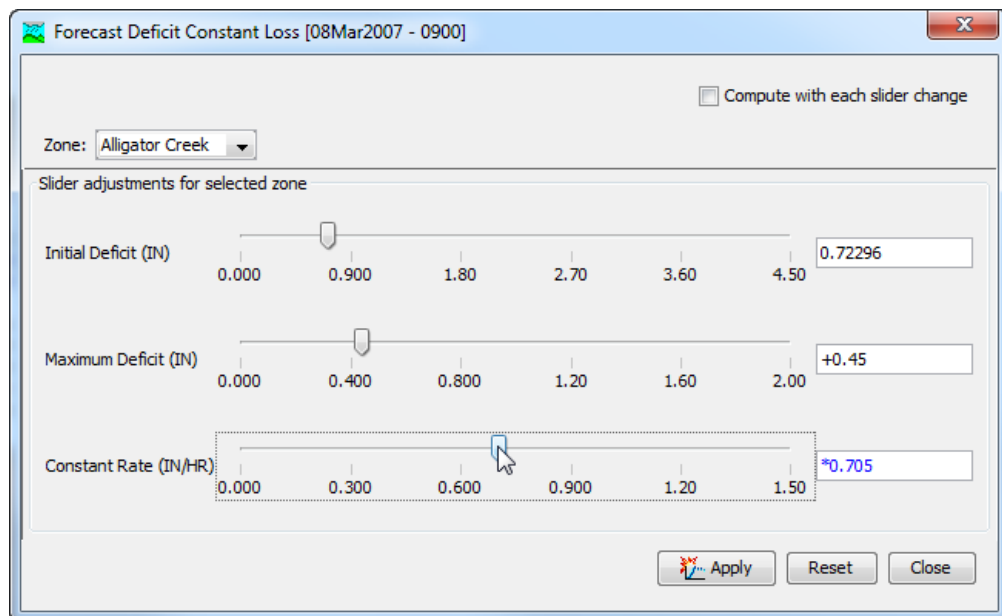

Figure 332. Using the slider adjustments editor to rapidly change the zone adjustments for loss rate parameters.

Slider adjustments are part of the parameter data for a forecast alternative. They can be selected or removed without affecting the zone parameter adjustments or element parameter overrides. The sliders for the current forecast alternative are accessed on the **Compute** menu by using the **Forecast Slider Adjustments...** command. The forecast slider adjustments manager opens and shows a separate tab for each loss rate, transform, baseflow, and routing method in the basin model used for the forecast alternative (Figure 333). The upper table on the tab shows all of the zone parameter adjustments that have been selected for a slider adjustment. Each adjustment that has been selected is shown on a separate row. Parameters from multiple zones will all be shown in the table. The lower table shows all of the element parameter overrides that have been selected for a slider adjustment. Each override has a separate

row and multiple elements in multiple zones are all shown together. The tables will be empty if no adjustments or overrides have been selected for slider adjustments.

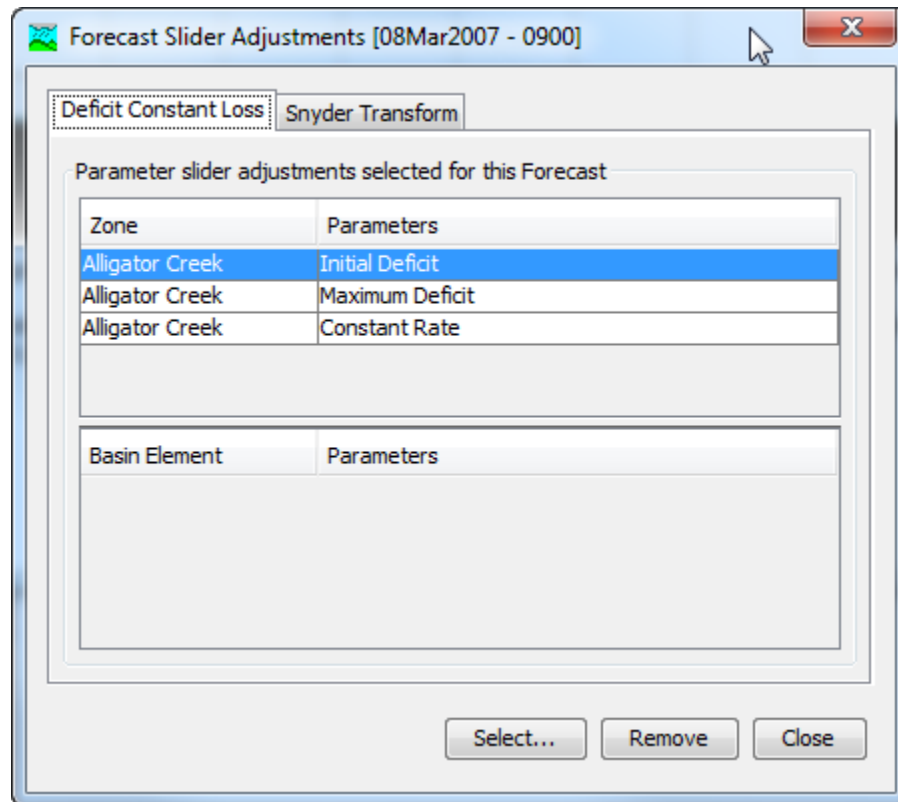

Figure 333. Viewing and managing the slider adjustments.

Select slider adjustments by clicking the **Select...** button (Figure 333). A window will open where zone parameter adjustments and element parameter overrides can be selected (Figure 334). A separate tab is included for each loss rate, transform, baseflow, and routing method in the basin model used for the forecast alternative.

Zone parameter adjustments are selected in the upper half of the screen. Clicking on a zone name will display all of the parameter adjustments that are available for selection. There are multiple ways to select an adjustment. You may click on a parameter adjustment and press the **Select** button. Alternately you may double click on a parameter adjustment and it will be selected. To select multiple adjustments simultaneously, hold the control key and click on each parameter adjustment. The selected adjustments are highlighted. Press the **Select** button to choose all of the selected adjustments. Press the **Close** button when you have finished selecting zone parameter adjustments.

Element parameter overrides are selected in the bottom half of the screen. Elements are only shown in the bottom half if they are in the

zone currently selected in the upper half. Click on a zone name in the upper half to select it; the selected zone will remain highlighted until a different zone is selected. Move to the bottom half and select an element by clicking on it. The available element parameter overrides will be shown after an element is selected. Overrides are selected in the same way as zone parameter adjustments by pressing the **Select** button or by double clicking on an override. Press the **Close** button when you have finished selecting element override adjustments.

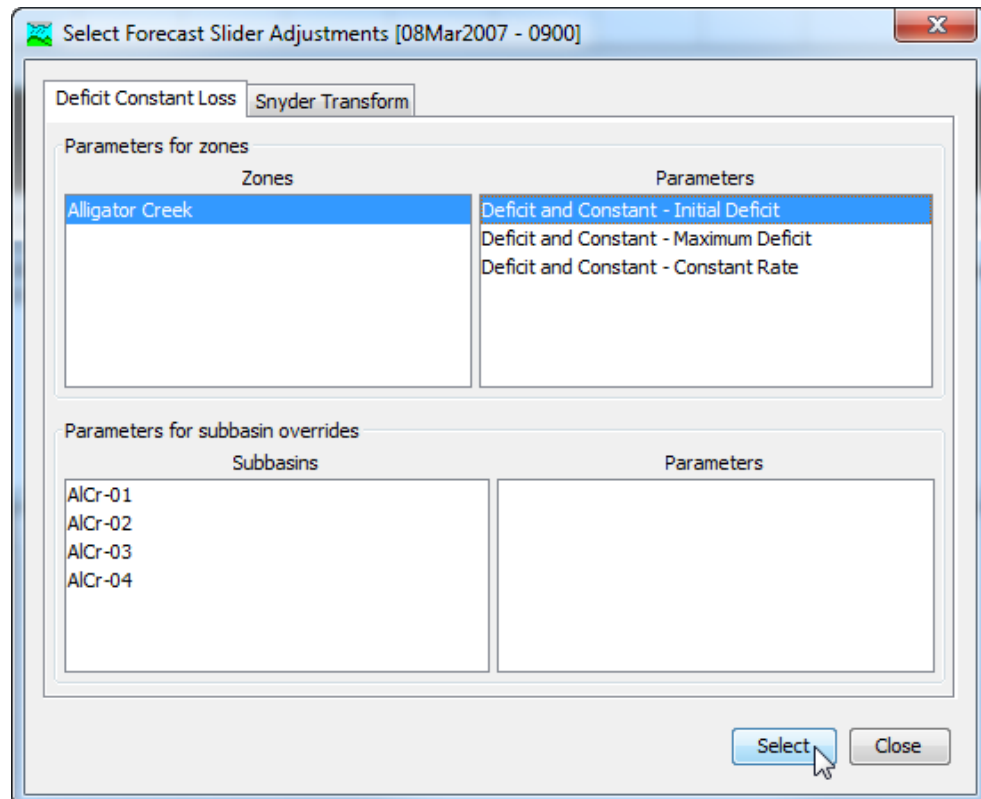

Figure 334. Selecting zone parameters for use as slider adjustments.

Slider adjustments can be removed from the forecast alternative using the select forecast slider adjustments manager (Figure 335). Access the manager for the current forecast alternative by selecting the **Compute** menu and clicking the **Forecast Slider Adjustments...** command. Remove a slider for a zone parameter adjustment by clicking on the adjustment. The adjustment is highlighted when it is selected. Press the **Remove** button and the slider will be removed from the slider adjustments. Slider adjustments for element overrides can be removed the same way. Multiple slider adjustments can be removed simultaneously by holding the control key and clicking on each of the adjustments before pressing the **Remove** button.

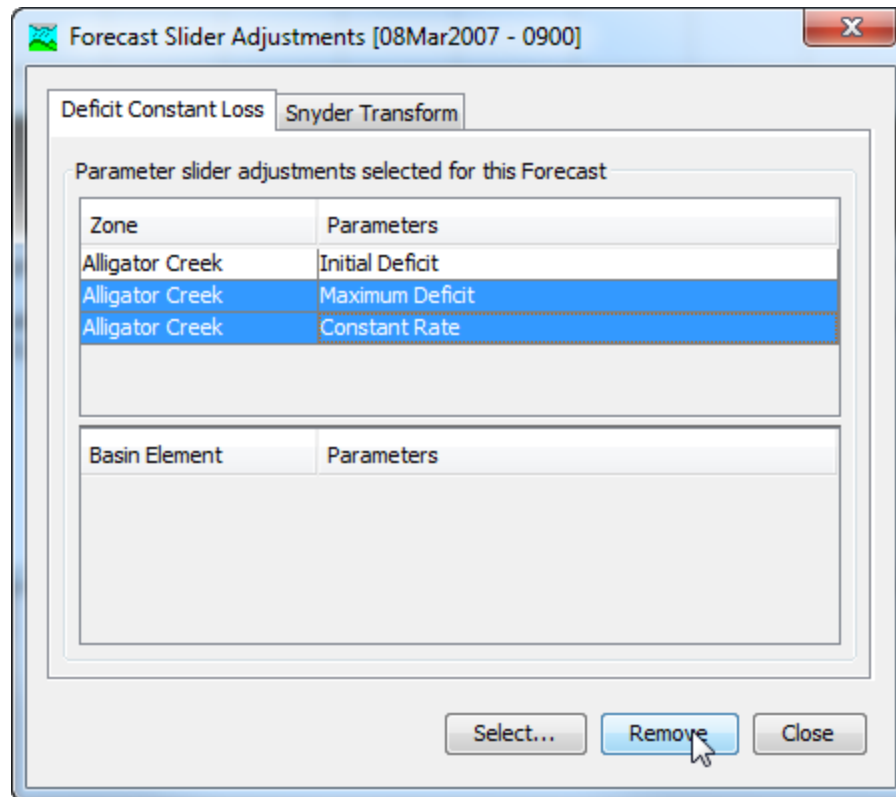

Figure 335. Preparing to remove two slider adjustments. Hold the control key and click multiple adjustments before pressing the **Remove** button.

Selecting slider adjustments is the first step in preparing them for use. Each slider adjustment must also be configured with the properties necessary to operate properly in the slider editor (Figure 332). Access the settings for the current forecast alternative by selecting the **Compute** menu and clicking the **Forecast Slider Settings...** command. The table in the upper half shows the slider adjustments for zone parameters (Figure 336). The first column displays the zone name while the second column shows the parameter name. The next column shows the selected adjustment type. The type may be a value, increment, or factor. The units of each zone parameter are shown for reference. The minimum value sets the left side of the slider range while the maximum sets the right side of the range. The minimum and maximum values should be specified carefully giving consideration to the nature of each parameter.

The table in the lower half shows the slider adjustments for element parameter overrides (Figure 336). The zone name, element name, and parameter name is shown for each slider adjustment. Use the same approach for entering the settings for element parameter overrides as for zone parameters. The slider adjustment settings can be closed when all configurations are complete.

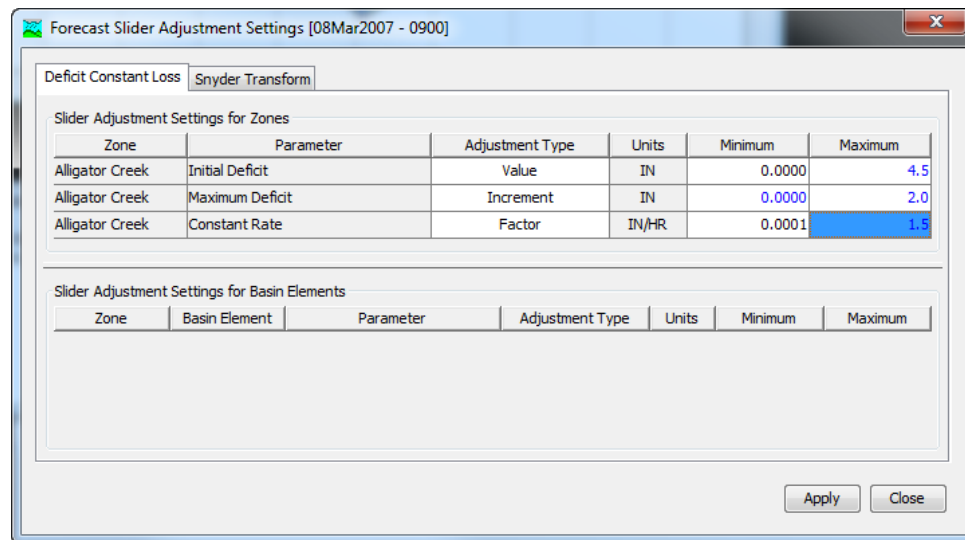

Figure 336. Configuring settings for the selected slider adjustments.

The slider adjustments can be opened from the forecast parameter adjustment editors (Figure 331). The editors are accessed on the **Compute** menu by using the **Forecast Parameter Adjustments** command. Pressing the **Slider Adjustments** button will open the slider editor; the button can only be pressed after the settings have been configured in the **Forecast Slider Settings** (Figure 336).

## Subbasin Baseflow Initialization

Baseflow typically sets the flow condition for subbasins at the beginning of a forecast simulation. All of the available baseflow methods include an initial flow condition at the start of the simulation. The initial condition may be specified as an absolute flowrate ( $\text{m}^3/\text{s}$  or  $\text{ft}^3/\text{s}$ ) or as a flowrate per area ( $\text{m}^3/\text{s}$  per  $\text{km}^2$  or  $\text{ft}^3/\text{s}$  per  $\text{mi}^2$ ). The flow determined from the initial condition typically recedes until precipitation begins generating surface flow.

Observed flow provides one good source for calculating the baseflow initial condition at the start of the simulation. In some cases observed flow may be available at the outlet of a subbasin and can be used directly as the baseflow initial condition. It is more common that there will be multiple subbasins above the observed flow location but this does not negate the use of observed flow. When there are multiple subbasins above the observed flow location, a ratio can be applied to the observed flow to calculate the baseflow initial condition for each subbasin. One approach to determining the ratio is to consider the subbasin area and the drainage area at the observed flow location. Baseflow initial calculation from observed flow can be accessed on the **Compute** menu using the **Forecast Initial Baseflow**. An example of the initial baseflow editor is shown in Figure 337.

This baseflow initialization feature is optional. When baseflow initialization is unused, subbasin flow is calculated purely from the basin model parameters, zone adjustments, and element overrides. The initialization feature may be applied at no subbasins, only one subbasin, several subbasins, or all subbasins.

Subbasins	Discharge Gage	Observed (CFS)	Minimum (CFS)	Maximum (CFS)	Default (CFS)	Ratio	Estimated Value (CFS)	Final Value (CFS)
Denton_Ck_S010	08053500 - DCJT2	308.0000	100	25000	350	0.29	89.3200	89.3200
Denton_Ck_S020	08053500 - DCJT2	308.0000	100	25000	350	0.43	132.4400	132.4400
Denton_Ck_S030	08053500 - DCJT2	308.0000	100	25000	350	0.16	49.2800	49.2800
Denton_Ck_S040	08053500 - DCJT2	308.0000	100	25000	350	0.13	40.0400	40.0400
Denton_Ck_S050	--None Selected--						7.5302	7.5302
Grapevine_S010	--None Selected--						18.949	18.9492
Denton_Ck_S070	--None Selected--						9.3553	9.3553
Denton_Ck_S060	--None Selected--						3.0783	3.0783

Figure 337. Using observed flow to automatically calculate initial baseflow.

The **Initial Baseflow** editor uses the baseflow zone configuration to assist in organizing data entry. The current zone is selected in the upper left corner of the editor. Each subbasin in the zone is shown on a separate row in the editor.

A discharge gage may be selected for each subbasin. Discharge gages must be created in the time-series gage manager before they can be selected for a subbasin. Usually the selected gage will be at the outlet of the subbasin or at some point downstream of the subbasin. The selected gage should be representative of flow conditions at the subbasin. The observed flow rate at the gage will be shown for the start time of the forecast alternative.

A minimum and maximum flow rate may be entered to qualify the use of the observed flow gage for calculating the initial baseflow. The minimum and maximum values are used in conjunction with the default flow value. If the observed flow is less than the minimum, then the default value will be used instead. The default will also be used if the observed flow is greater than the maximum. The minimum or maximum can be left blank if the observed flow should be used without a lower or upper limit. Finally, the default value will be used if the observed flow is missing at the start time of the forecast alternative.



The observed flow from the selected gage is multiplied by the specified ratio in order to calculate the initial baseflow estimated value. The ratio is only used if the observed flow is between the minimum and maximum values. It is required for the ratio to be greater than zero and it may be greater than one. However, using a ratio greater than one should generally only be done if the observed flow is not downstream of the subbasin; this should be done only after careful analysis.

The estimated value is calculated from the observed flow gage using the ratio and substituting the default value according to the minimum and maximum values. At first, the estimated value is also copied as the final value. The final value can be edited to override the estimated value. Editing the final value may be necessary if current flow conditions diverge from the assumptions used to develop the ratio. The final value for each subbasin shown in the table will be reset to the estimated value when the **Reset** button is pressed.

## ***Reservoir Pool Initialization and Reset***

Pool storage plays a key role in determining reservoir discharge. The initial storage must be specified in every reservoir at the start of the forecast. By default the initial storage in each reservoir is taken from the selected basin model. However, this value should be updated based on conditions at the start of the forecast.

Storage often cannot be observed directly but can be calculated from the current pool elevation. A variety of instruments are available for observing the pool elevation. The observed elevation provides the best method for determining the pool storage at the start of the forecast. The observed elevation at the forecast time also provides an opportunity for updating the pool storage if the simulated storage has diverged since the start time.

All of the reservoir routing methods provide multiple choices for specifying the initial pool storage. However, only initial elevation is used with the forecast alternative; initial elevation should be selected as the initial condition for each reservoir in the basin model. Choosing the initial elevation option facilitates adjusting storage directly for the forecast alternative using a special editor. The **Forecast Reservoirs** editor is accessed from the **Compute** menu after a forecast alternative is selected. An example of the forecast reservoirs editor is shown in Figure 338.

The **Forecast Reservoirs** editor provides three choices for handling time-series data from the forecast time to the end time. The same choice is applied to all reservoir elements in the basin model. It is used for any discharge time-series selected at the reservoir. The

Replace All With Zero choice will substitute zero discharge for all time intervals after the forecast time even if some observed or specified values may be available from the time-series manager. The Replace Missing With Zero choice will substitute zero for any missing values between the forecast time and end time. The Replace Missing With Last choice will substitute the last observed or specified value prior to the missing value during the period from the forecast time to the end time.

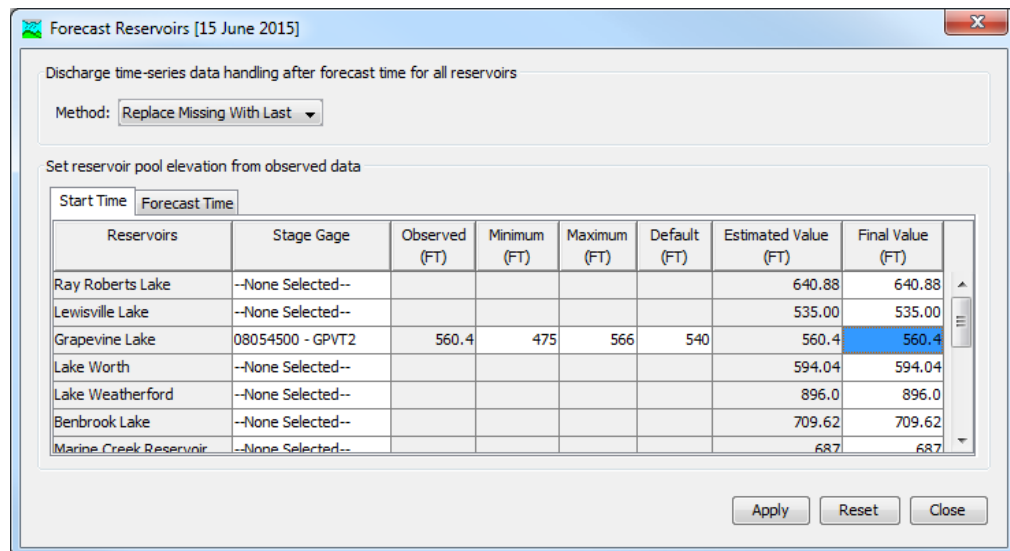

Figure 338. Setting reservoir initial pool elevation at the forecast start time.

The **Forecast Reservoirs** editor uses two tabs for separating initial pool elevation at the start time from resetting the pool elevation at the forecast time. Each reservoir in the basin model is shown on a separate row in the editor. The "Start Time" tab corresponds to the start time of the forecast alternative while the "Forecast Time" tab is for the forecast time of the alternative.

The "Start Time" tab is where a stage gage may be selected for each reservoir. Pool elevation is taken from a stage gage that must be created in the time-series gage manager before it can be selected for a reservoir. The selected gage should represent a pool elevation observation at the reservoir. The observed elevation will be shown for the start time of the forecast alternative.

A minimum and maximum elevation may be entered to qualify the use of the observed stage gage for calculating the initial storage. The minimum and maximum values are used in conjunction with the default value. If the observed value is less than the minimum, then the default will be used instead. The default will also be used if the observed value is greater than the maximum. The minimum or maximum can be left blank if the observed value should be used without a lower or

upper limit. A reasonable value for the minimum is the lowest elevation in the reservoir pool, while a good value for the maximum is the highest allowable elevation in the pool. Finally, the default will be used if the observed value is missing at the start time of the forecast alternative.

The estimated value is calculated from the observed stage gage by substituting the default value according to the minimum and maximum values. At first, the estimated value is also copied as the final value. The final value can be edited to override the estimated value. Editing the final value may be necessary if current conditions compromise the pool elevation observation, such as during high winds. The final value for each reservoir shown in the table will be reset to the estimated value when the **Reset** button is pressed.

Forecast Reservoirs [15 June 2015]

Discharge time-series data handling after forecast time for all reservoirs

Method:

Set reservoir pool elevation from observed data

Start Time  Forecast Time

Reservoirs	Stage Gage	Observed (FT)	Minimum (FT)	Maximum (FT)	Default (FT)	Estimated Value (FT)	Final Value (FT)
Ray Roberts Lake	--None Selected--						
Lewisville Lake	--None Selected--						
Grapevine Lake	--None Selected--						
Lake Worth	08045400 - FLWT2	596.5	567	608	585	596.5	596.5
Lake Weatherford	--None Selected--						
Benbrook Lake	--None Selected--						
Marine Creek Reservoir	--None Selected--						

Figure 339. Resetting the reservoir pool elevation at the forecast time.

The "Forecast Time" tab allows the reservoir storage to be reset at the forecast time of the alternative. The selection of the stage gage, minimum value, maximum value, and default value are shown for each reservoir. However, these properties are set on the "Start Time" tab and are only repeated for easy reference.

The "Forecast Time" tab shows the observed elevation at the start time of the forecast alternative. The observed value will be blank if the data is missing at the forecast time. The estimated value is calculated from the observed stage gage by substituting the default value according to the minimum and maximum values. The default value is also substituted if the observed value is missing. At first, the estimated value is also copied as the final value. The final value can be edited to override the estimated value. The final value for each reservoir shown

in the table will be reset to the estimated value when the **Reset** button is pressed.

## ***Blending Computed Flow with Observed Flow***

The computed streamflow is never perfect. The accuracy of computed results will vary with the quality of the model, expertise of the forecaster, knowledge of antecedent conditions in the watershed, accuracy of precipitation and other meteorologic data, and other factors. Blending provides a method for systematically using observed flow to adjust computed streamflow. Using observed flow for blending is optional. When blending is unused, flow is calculated purely from the basin model parameters, zone adjustments, element overrides, baseflow initialization, and reservoir initialization and reset.

Blending is applied after outflow is computed at an element using the selected methods and specified parameter values. The computed streamflow is replaced with the observed flow during the period from the start time up to the time of forecast; this is the period during which observed data is available. There will be some difference between the computed streamflow and the observed flow at the forecast time. A transition from observed flow to computed streamflow is applied starting at the forecast time. The computed streamflow is used after the transition is complete through to the end time. The final blended streamflow becomes the outflow to the downstream element. The quality of the final blended streamflow depends directly on the quality of the observed flow data and the quality of the model.

Three different options are available for performing the transition between observed flow and computed streamflow. The "Step" option applies a fixed correction to the computed streamflow from the forecast time to the end time. The difference between the observed flow and computed streamflow is calculated at the forecast time. The difference (positive if observed flow is greater than computed streamflow, negative if observed flow is less than computed streamflow) is added to the computed streamflow from the forecast time to the end time. The "Taper" option applies a decreasing correction to the computed streamflow after the forecast time. The difference between the observed flow and computed stream flow is calculated at the forecast time. This initial difference is added to the computed streamflow at the forecast time. The difference is then decreased linearly over the taper duration. At the end of the taper duration the applied correction is exactly zero. The computed streamflow is then used from the end of the taper duration to the forecast alternative end time. The "None" option applies no correction to the computed streamflow after the forecast time. There will be an instantaneous jump from the observed flow to the computed streamflow at the forecast time.

Blending is configured using the blending editor for the forecast alternative. The editor is accessed on the **Compute** menu by using the **Forecast Blending** command. A blending editor is shown that includes all elements in the basin model with observed flow (Figure 340). Blending may be turned on or off for each element. When blending is off, the computed streamflow is used for the entire time window from start time to end time even though observed flow is available. When blending is turned on, the blending transition method must be selected from the available choices. A taper duration must be entered if the taper blending option is selected.

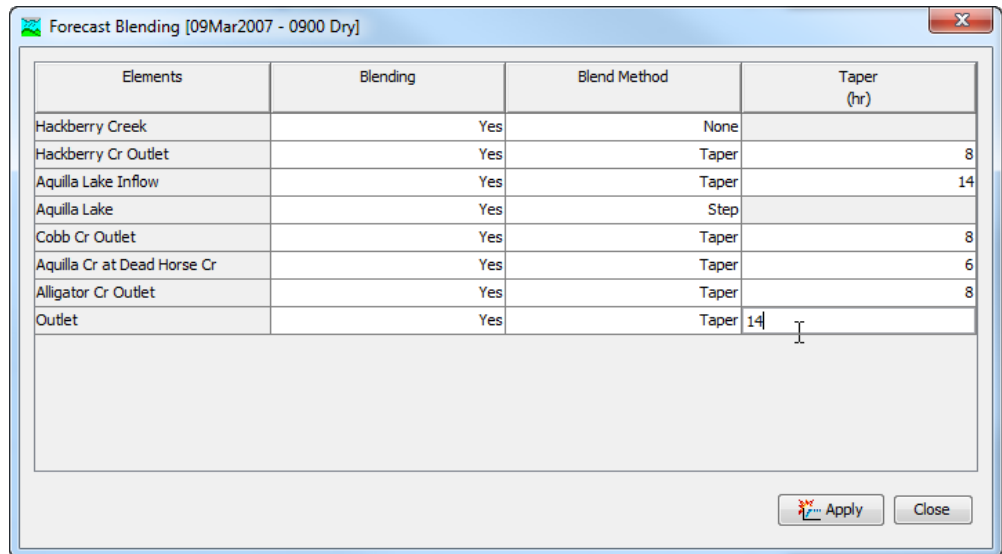

Figure 340. Setting the blending properties for each element with observed flow.

## Computing Results for an Alternative

Results for a forecast alternative are generated by computing it. Changes in all the components used in the alternative are automatically tracked to determine if the results are current. When the results are no longer current, the alternative must be recomputed in order to refresh the results. Computing results begins with selecting a forecast alternative.

### Selecting a current Forecast Alternative

There are two ways to select the current forecast alternative. Both methods set the alternative so that it can be computed and results can be accessed from the *Watershed Explorer* and the basin map as soon as they are available. The current forecast alternative is shown in the title of the basin map.

The first way to select the current forecast alternative is from the toolbar. The compute selection box shows all of the compute components in the project; forecast alternatives appear after optimization trials in the selection box. Each forecast alternative in the selection box includes the prefix `Forecast` followed by the name of the alternative. Click on the toolbar selection box and choose a forecast alternative to become the current alternative.

The second way to select the current forecast alternative is from the *Watershed Explorer*, on the "Compute" tab. Select the forecast alternative you wish to become the current alternative by clicking on it in the *Watershed Explorer*. The forecast alternatives are listed alphabetically in the "Forecast Alternatives" folder.

### **Computing a Forecast Alternative**

There are three ways to compute the currently selected forecast alternative. All methods automatically perform parameter checking, and if no errors are generated, proceed to the actual computing of forecast alternative results. Additionally, the program is designed to be computationally efficient. Only components with data changes since the last compute will be recomputed; the remainder of the components have not changed so previous alternative results are still applicable. If you wish, you may force all components to be recomputed regardless of data changes since the last compute.

The first way to compute a forecast alternative is from the **Compute** menu. Click on the **Compute** menu and then select the **Compute Forecast** command. The name of the current forecast alternative is shown in brackets as part of the menu command. If the command is not available, it is because there is no current forecast alternative; you must first select an alternative. A window will automatically open that shows the progress of the compute. You will need to manually close the window when the compute is done, whether it failed or was successful. If you wish to force all components to be recomputed instead of just those with data changes, hold the *control* key while selecting the menu command.

The second way to compute a forecast alternative is from the *Watershed Explorer*, on the "Compute" tab. Select the forecast alternative you wish to compute by clicking on it in the *Watershed Explorer* with the right mouse button. A context menu is displayed that contains several choices including compute. Click the **Compute** command. The progress window will automatically open. If you wish to force all components to be recomputed instead of just those with data changes, hold the *control* key while selecting the right mouse menu command.

The third way to compute a forecast alternative is from the toolbar. The compute button is enabled whenever there is a current alternative that can be computed. If the button is not available or shows a different type of compute, you must first select a forecast alternative. Press the button to compute the current forecast alternative. The progress window will automatically open. If you wish to force all components to be recomputed instead of just those with data changes, hold the *control* key while selecting the toolbar button.

### ***Computing to a Computation Point***

Any hydrologic element in a basin model can be designated as a computation point. Selecting a computation point and unselecting a point is described in [Chapter 6](#). It is also possible to compute a forecast alternative to a computation point. This method of computing results only computes the hydrologic element designated as a computation point plus any elements upstream of the point. It is common for elements with observed flow to be designated as computation points. One approach to performing calibration adjustments is to start at the most-upstream element with observed flow. After adjusting parameters above the upstream point, calibration efforts are focused on the drainage between the upstream point and the next point downstream. Computing to a point supports this calibration approach.

A forecast alternative can be computed to a point from the *Basin Model Map* window whenever an alternative is selected. Right-click on a computation point in the map and select the **Compute To Point** command (Figure 341). The command can only be selected when there is a current forecast alternative and the element has been designated as a computation point.

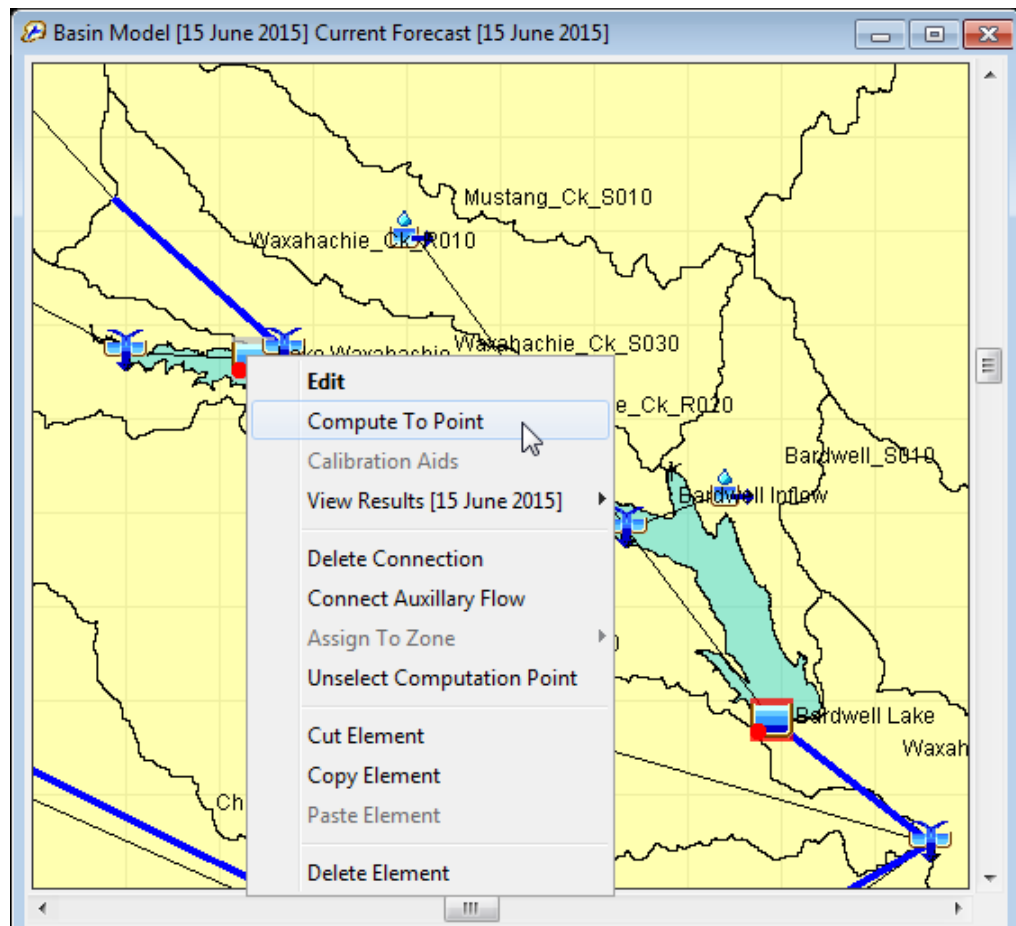

Figure 341. Computing forecast alternative results to an element that has been designated a computation point.

### Computing Multiple Alternatives

Multiple forecast alternatives can be computed in rapid succession. Each simulated alternative is internally managed the same as if it were computed in isolation. The steps performed for the user begin with selecting the forecast alternative, checking parameters for the alternative, and finally computing the simulation. This sequence is repeated in rapid succession for each forecast alternative in the selected set. Appropriate feedback is provided through a progress bar.

The multiple forecast alternatives must exist before they can be selected for a multiple compute. Select the **Multiple Compute** command on the **Compute** menu. A manager is used to select forecast alternatives (Figure 342). Make selections in the list and then press the **Compute** button to begin computing the selected alternatives. A separate progress bar will be displayed for each forecast alternative as it is computed. The progress bar may disappear automatically at the conclusion of a forecast alternative depending on the configurations in the *Program Settings*. If errors are



encountered while computing an alternative, the progress bar will always remain visible after all selected analyses have finished computing regardless of any other settings.

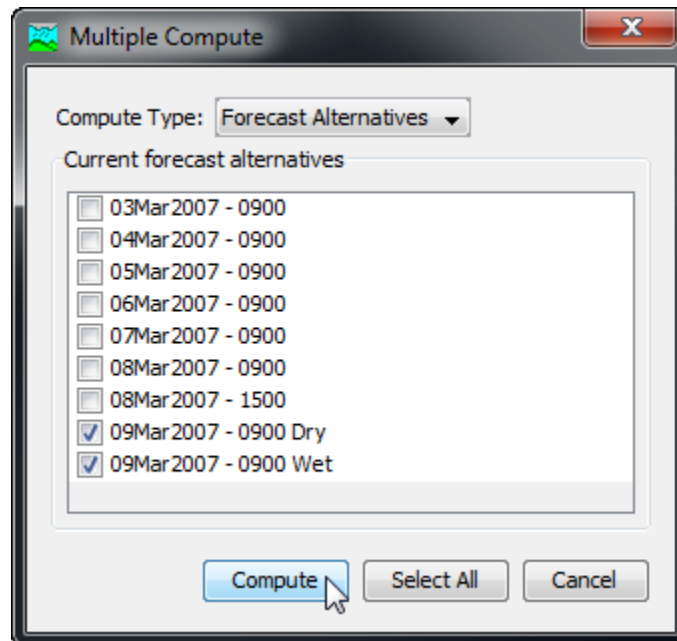

Figure 342. Selecting multiple forecast alternatives for sequential compute.

## Viewing Results for the Current Alternative

A variety of graphical and tabular results are available after a forecast alternative is computed. The same results are also available for the current alternative, so long as no data used in the alternative has changed. The program tracks all of the data in the forecast alternative and all of the data used in the basin model and meteorologic model that are the basis of the forecast alternative. Results for a forecast alternative are only available when none of this data has changed since the last time the alternative was computed. If any of the data has changed, you will need to recompute the forecast alternative before you will be allowed to view results.

Once a result is open for viewing it will remain open until it is closed by the user. It is possible that data used during the simulation that produced the result could change while the result is open for viewing. In this case, the open result will immediately show an indication that data has changed and the forecast alternative needs to be recomputed. After the forecast alternative is recomputed the open results are automatically updated with the new results and the indication is updated with the data and time of the most-recent compute.

## Individual Elements

There are three ways to access results for individual elements in the current forecast alternative. All methods show the same results. You must select one or more elements in the basin map before you can view results for that element.

The first method for viewing individual element results is to use the **Results** menu. You may need to first open the basin model by clicking on it in the *Watershed Explorer*, on the "Components" tab. The current forecast alternative is shown in brackets in the basin map title bar. Select one or more elements in the basin map by clicking with the arrow tool. With an element selected in the basin map, click the **Results** menu and select the **Element Graph** command, the **Element Summary Table** command, or the **Element Time-Series Table** command. The appropriate result will automatically be shown in the *Desktop* area. The information included in the graph (Figure 343) varies by element type, but always includes outflow. Optional items such as observed flow, computed stage, and observed stage are also included.

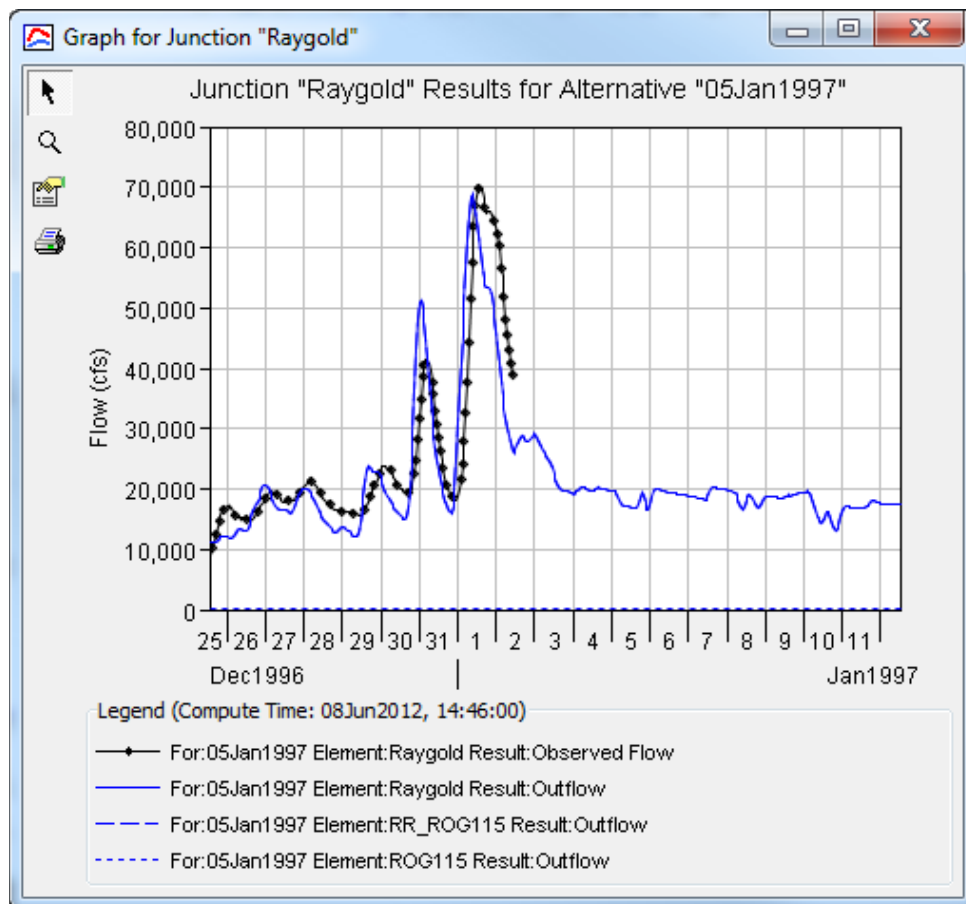

Figure 343. Element graph for a junction after a forecast alternative.

The information included in the summary table (Figure 344) also varies by element type but always includes the peak flow, time of peak flow, and outflow volume. The time-series table includes the same information as the graph but in numerical format (Figure 345). If you selected more than one element, then one result for each element will open. The menu commands on the **Results** menu will only be enabled if the results for the current forecast alternative do not need to be recomputed, and there is an element selection in the basin map.

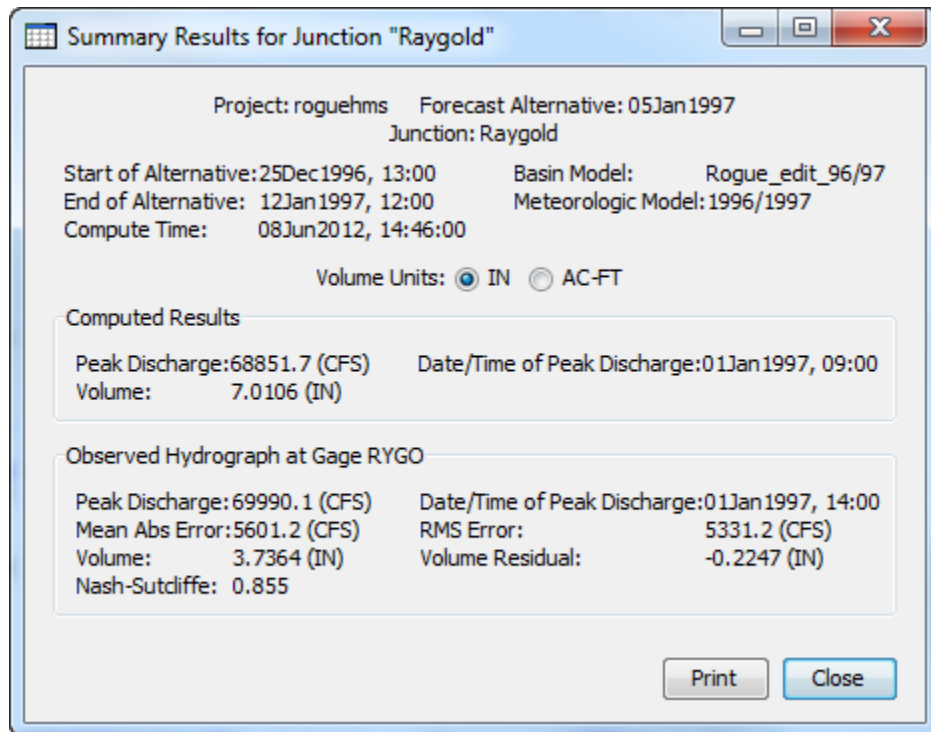

Figure 344. Element summary table for a junction after a forecast alternative.

Project: roguehms Forecast Alternative: 05Jan1997  
Junction: Raygold

Start of Alternative: 25Dec1996, 13:00 Basin Model: Rogue\_edit\_96/97  
End of Alternative: 12Jan1997, 12:00 Meteorologic Model: 1996/1997  
Compute Time: 08Jun2012, 14:46:00

Date	Time	Inflow from... (CFS)	Inflow from... (CFS)	Outflow (CFS)	Obs Flow (CFS)
02Jan1997	08:00	28746.5	0.8	28747.3	43146.8
02Jan1997	09:00	27428.5	0.8	27429.3	40708.6
02Jan1997	10:00	26410.2	8.7	26418.9	39029.4
02Jan1997	11:00	26065.5	1.8	26067.4	38515.9
02Jan1997	12:00	26496.0	0.7	26496.7	
02Jan1997	13:00	27265.8	3.2	27269.0	
02Jan1997	14:00	27960.0	1.1	27961.0	
02Jan1997	15:00	28519.3	0.7	28520.0	
02Jan1997	16:00	28705.1	0.7	28705.8	
02Jan1997	17:00	28485.8	2.4	28488.2	
02Jan1997	18:00	28158.1	3.0	28161.1	
02Jan1997	19:00	27973.9	5.1	27979.1	

Print Close

Figure 345. Element time-series table for a junction after a forecast alternative.

The second method for viewing individual element results is to use the element icon in the basin map. Again you may need to open the basin model and select a current forecast alternative before attempting to view results. Click on an element to highlight it. Keep the mouse over the element and press the right mouse button. A context menu is displayed that contains several choices including **View Results**. The name of the current forecast alternative is shown in brackets after the menu command. Move the mouse into the **View Results** submenu and select any of the result commands: **Graph**, **Summary Table**, or **Time-Series Table**. The appropriate result will open. If you selected more than one element, then one result for each element will open. The **View Results** menu command will only be enabled if the results for the current forecast alternative do not need to be recomputed.

The third method for viewing individual element results is to use the buttons on the toolbar. First you must open the basin model, select a current forecast alternative, and select one or more elements in the basin map by clicking with the arrow tool. Once you have a selected element, click the graph, summary table, or time-series table buttons. The button for selecting a graph shows a line plot. The button for the summary table shows a plain table. The button for the time-series table shows a table plus a clock. The appropriate result will

automatically open. If you selected more than one element, then one result for each element will be added to the *Desktop*. The toolbar buttons for viewing element results will only be enabled if the results for the current forecast alternative do not need to be recomputed, and there is an element selection in the basin map.

## **Viewing Results for Other Alternatives**

In addition to viewing results for the currently selected forecast alternative, it is also possible to view results for other alternatives that are not the current selection. However, those other alternatives are also tracked in the same way as the current forecast alternative to make sure data has not changed and results do not need to be recomputed. If any of the data in a forecast alternative changes, it will have to be recomputed before results can be viewed. Results for other forecast alternatives are accessed from the *Watershed Explorer*, on the "Results" tab.

To begin viewing results, go to the "Results" tab of the *Watershed Explorer* and click on the desired forecast alternative icon. If necessary, click on the "Forecast Alternatives" folder to expand it and view the alternative in the project. The forecast alternative icon will be disabled if any data used in the alternative has changed and results need to be recomputed. If any result is open at the time data changes, the affected results will be automatically updated.

### **Individual Elements**

Each element in the basin model used in the forecast alternative is shown in the *Watershed Explorer* under the forecast alternative node. These elements are listed in hydrologic order. The results for each element are accessed by clicking on its node. The first item listed for each element is the graph; click on the "Graph" node to view the result (Figure 346). It is exactly the same graph that can be viewed for the current forecast alternative. The information included in the graph varies by element type but always includes outflow. Optional items such as observed flow, computed stage, and observed stage are also included. Similarly, the summary table and time-series table can also be accessed by clicking on the "Summary Table" or "Time-Series Table" node, respectively.

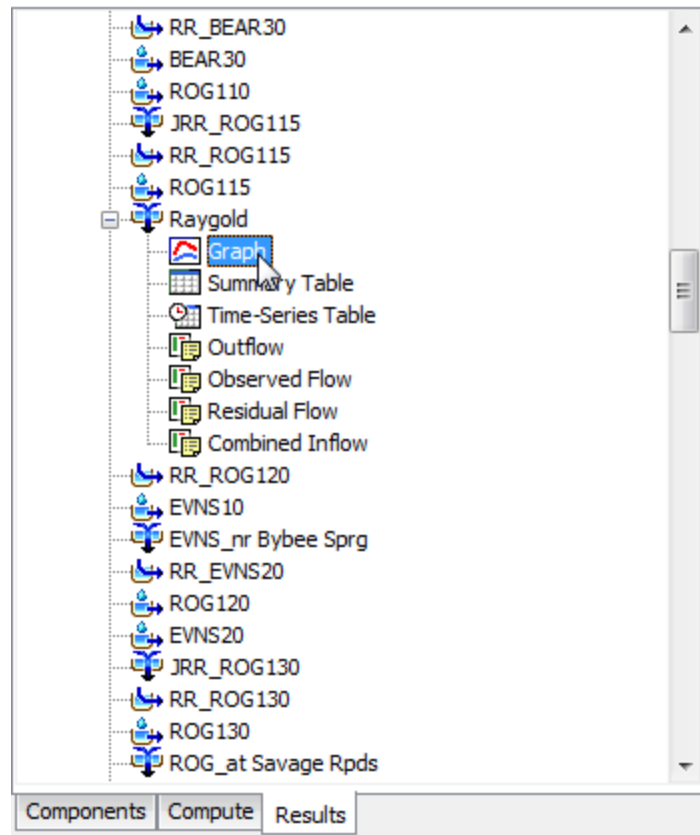

Figure 346. Viewing forecast alternative results in the Watershed Explorer.

### Element Time-Series Preview Graph

All of the time-series data computed by an individual element are available for viewing. The time-series data are listed under each element node in the *Watershed Explorer*. The first node under each element is the graph, followed by the summary table and time-series table. The remaining nodes for each element represent the different time-series data. Click on a time-series node to preview the data in the *Component Editor*. You may select multiple time-series data by holding the shift or control key while using the mouse to click on additional nodes (Figure 347). The selected time-series may come from different elements in the same forecast alternative, or the same element in different alternatives. Results can also be combined from simulation runs, optimization trials, depth-area analyses, and forecast alternatives. The selected time-series data will automatically be partitioned into groups by data type.

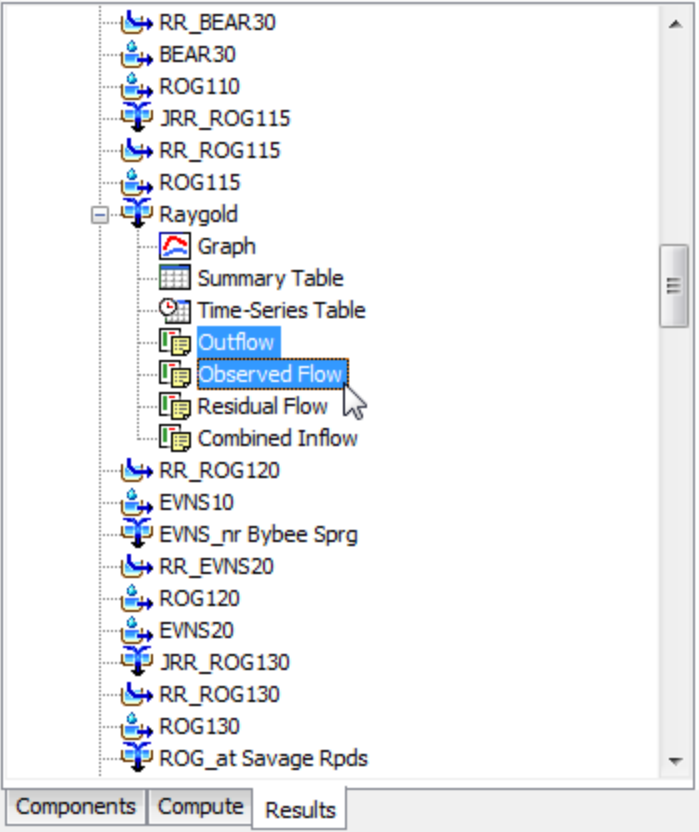

Figure 347. Viewing forecast alternative results in the Watershed Explorer. Results can be selected at multiple elements in the same alternative, or in different alternatives.

## Time-Series Tables and Graphs

Preview graphs of selected time-series data can be opened as graphs or time-series tables within the *Desktop* area. Begin by selecting the time-series you wish to include in the graph or table. Once you have selected the desired time-series, you can press the graph or time-series table buttons on the toolbar. The chosen time-series will be graphed or tabulated (Figure 348).

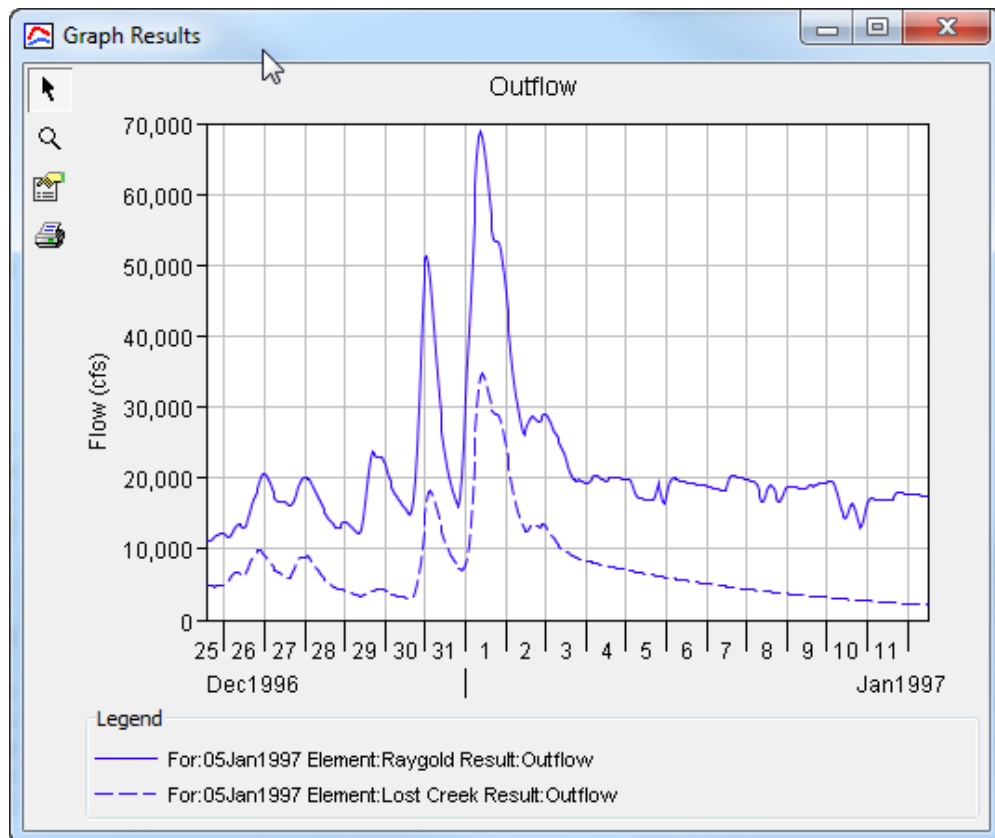

Figure 348. Forecast streamflow at locations upstream (Lost Creek) and downstream (Raygold) in the same watershed.

After you have opened a time-series table or graph, you may add additional time-series results. Position the mouse over the time-series result you wish to add to the graph or table. Press and hold the left mouse button and then drag the mouse over the top of the graph or table where you want the result to be added. The mouse cursor will change to indicate which tables and graphs can accept the additional time-series. Release the mouse button while it is over the desired table or graph and it will be automatically updated to show the additional time-series results.



## **Changing Graph Properties**

All of the graphs open with default properties for line color, line style, data symbols, etc. These default properties have been selected to be appropriate for most situations. However, it is possible to customize the properties in a graph. To change the properties, first click on the graph to select it. Next go to the **Results** menu and select the **Graph Properties...** command. An editor will open that can be used to change the properties of the selected graph. The properties for each time-series curve can be changed. It is also possible to change the properties for the axis, title, gridlines, patterns, and legend. The editor used to change properties is the same as used for simulation run graphs shown in Figure 294.

This Page Left Blank

## CHAPTER 15

# ***Depth-Area Reduction***

One of the principal results in many water resource studies is a flow-frequency curve. A common way to develop a frequency curve is to use frequency precipitation events in combination with a hydrologic model. A study of a large watershed usually includes multiple evaluation points in the stream network. The depth-area analysis automates the process of producing flow estimates due to frequency precipitation at multiple points of interest within a watershed.

### ***Depth-Area Analyses***

A depth-area analysis is designed to assist in the process of developing peak flows in a watershed due to frequency precipitation. For example, it may be the goal to compute the streamflow expected to result from the storm with 1% exceedance probability. The usual assumption is that the 1% precipitation will result in the 1% flow, and that the hydrology model can accurately simulate the conversion of precipitation to flow. Developing the flow values throughout a watershed for a specific exceedance probability is a key step in developing flow frequency curves.

Storm area is a key component of a frequency storm. The area is used to determine the appropriate depth-area reduction factor. The depth-area reduction factor is used to account for the observation from empirical data that average precipitation intensity decreases as the area of a storm increases. Thus the average precipitation intensity of a 200 km<sup>2</sup> storm is generally much less than the intensity of a 10 km<sup>2</sup> storm. Proper determination of the flow at a given evaluation point in the watershed requires that the frequency storm have an area equal to the drainage area at that point. Failure to match the storm area to the drainage area can result in significant under or over estimation of the flow. It is simple enough to setup a simulation run with the meteorologic model set to compute flow at a particular evaluation point. However, it is often the case that the flow must be estimated at many points in the watershed.

The depth-area analysis automates the process of developing a separate frequency storm for each evaluation point. The analysis requires the specification of an underlying simulation run that must use a meteorologic model set to use the frequency storm precipitation method. The analysis also includes the listing of various analysis points where the flow should be evaluated. When the analysis

computes, it automatically generates frequency storms based on the one specified in the meteorologic model but with appropriate storm area for each analysis point. The instantaneous peak flows at each analysis point are automatically collected and available in a tabular display.

Depth-area analyses are one of the components that can compute results. Each analysis is based on a simulation run. The meteorologic model selected in the simulation run must use the frequency precipitation method. The analysis also includes the selection of evaluation points within the basin model. A summary table with the key flow information necessary for constructing a flow-frequency curve is available from the *Watershed Explorer*.

### **Creating a New Depth-Area Analysis**

A new depth-area analysis is created using a wizard that helps you navigate the steps to creating a new analysis. There are two ways to access the wizard. The first way to access the wizard is to click on the **Compute** menu and select the **Create Compute ⇒ Depth-Area Analysis** command; it is only enabled if at least one simulation run exists. The wizard will open and begin the process of creating a new depth-area analysis. The second way to access the wizard is from the *Depth-Area Analysis Manager*. Click on the **Compute** menu and select the **Depth-Area Analysis Manager** command. The *Depth-Area Analysis Manager* will open and show any analyses that already exist. Press the **New...** button to access the wizard and begin the process of creating a depth-area analysis, as shown in Figure 349.

The first step of creating a depth-area analysis is to provide the name for the new analysis (Figure 350). A default name is provided for the new analysis; you can use the default or replace it with your own choice. After you finish creating the analysis you can add a description to it. If you change your mind and do not want to create a new depth-area analysis, you can press the **Cancel** button at the bottom of the wizard or the **X** button in the upper right corner of the wizard. The **Cancel** button can be pressed at any time you are using the wizard. Press the **Next>** button when you are satisfied with the name you have entered and are ready to proceed to the next step.

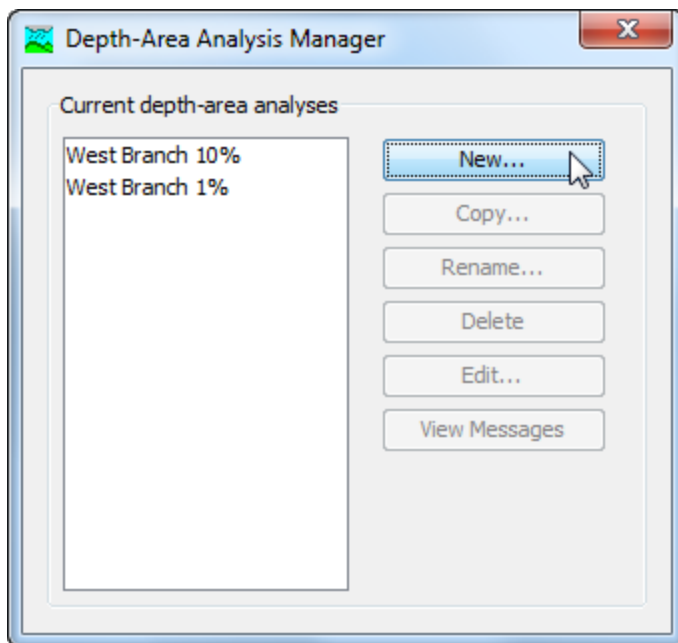

Figure 349. Beginning the process of creating a new depth-area analysis using the Depth-Area Analysis Manager.

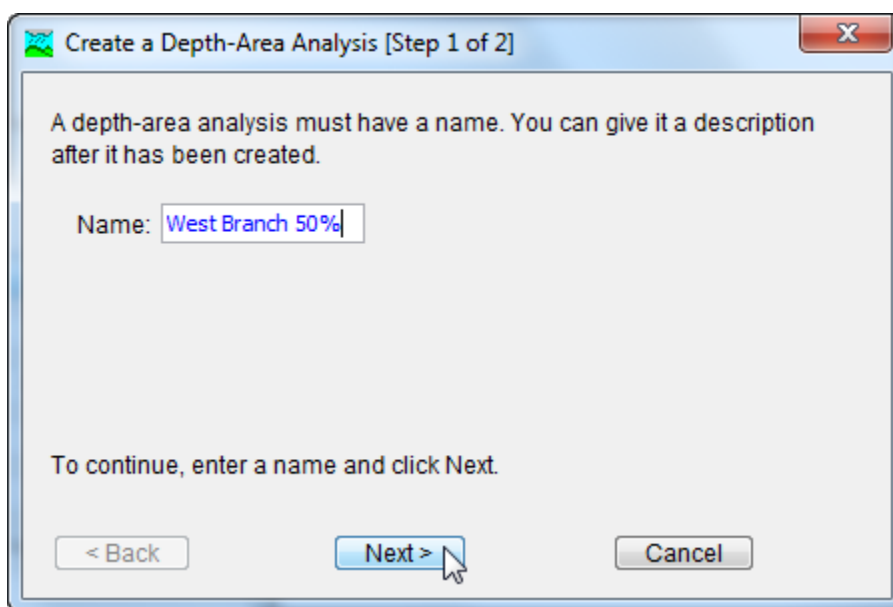

Figure 350. The first step of creating a new depth-area analysis is to enter a name for the new analysis. The remaining step is to select a simulation run that uses the frequency precipitation method.

The second step of creating a depth-area analysis is to select a simulation run. The simulation run combines a basin model, meteorologic model, and control specifications to compute results. The meteorologic model selected in the simulation run must use the frequency precipitation method. All of the simulation runs where the meteorologic model uses the frequency precipitation method are

displayed in alphabetical order. By default the first simulation run in the table is selected. The selected run is highlighted. You can use your mouse to select a different run by clicking on it in the table of available choices. You can also use the arrow keys on your keyboard to select a different run. Press the **Finish** button when you are satisfied with the name you have entered and the simulation run you have selected, and are ready to create the depth-area analysis. Press the **<Back** button if you wish to return to the previous step and enter a different name for the analysis.

### ***Copying a Depth-Area Analysis***

There are two ways to copy a depth-area analysis. Both methods for copying an analysis create an exact duplicate with a different name. Once the copy has been made it is independent of the original and they do not interact.

The first way to create a copy is to use the *Depth-Area Analysis Manager*, which is accessed from the **Compute** menu. Select the depth-area analysis you wish to copy by clicking on it in the list of current analyses. The selected analysis is highlighted after you select it. After you select an analysis you can press the **Copy...** button on the right side of the window. The *Copy Depth-Area Analysis* window (Figure 351) will open where you can name and describe the copy that will be created. A default name is provided for the copy; you can use the default or replace it with your own choice. A description can also be entered; if it is long you can use the button to the right of the description field to open an editor. When you are satisfied with the name and description, press the **Copy** button to finish the process of copying the selected depth-area analysis. You cannot press the **Copy** button if no name is specified. If you change your mind and do not want to copy the selected depth-area analysis, press the **Cancel** button or the **X** button in the upper right to return to the *Depth-Area Analysis Manager* window.

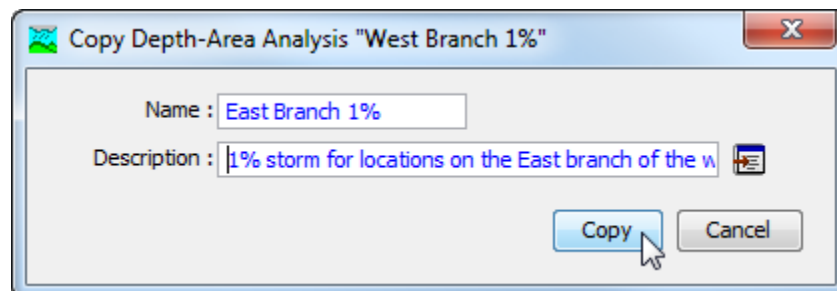

Figure 351. Creating a copy of a depth-area analysis.

The second way to copy is from the "Compute" tab of the *Watershed Explorer*. Move the mouse over the depth-area analysis you wish to copy and press the right mouse button (Figure 352). A context menu

is displayed that contains several choices including copy. Click the **Create Copy...** command. The *Copy Depth-Area Analysis* window will open where you can name and describe the copy that will be created. A default name is provided for the copy; you can use the default or replace it with your own choice. A description can also be entered; if it is long you can use the button to the right of the description field to open an editor. When you are satisfied with the name and description, press the **Copy** button to finish the process of copying the selected depth-area analysis. You cannot press the **Copy** button if no name is specified. If you change your mind and do not want to copy the selected depth-area analysis, press the **Cancel** button or the **X** button in the upper right of the *Copy Depth-Area Analysis* window to return to the *Watershed Explorer*.

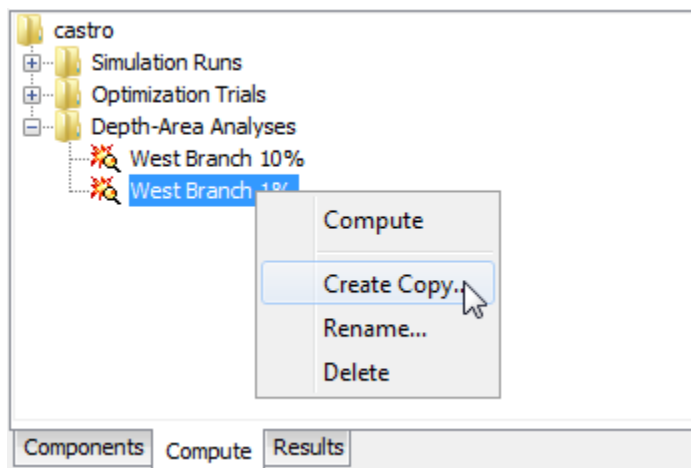

Figure 352. Copying a depth-area analysis from the Watershed Explorer. The *Copy Depth-Area Analysis* window will appear after the *Create Copy...* menu command is selected.

## Renaming a Depth-Area Analysis

There are two ways to rename a depth-area analysis. Both methods for renaming an analysis change its name and perform other necessary operations.

The first way to perform a rename is to use the *Depth-Area Analysis Manager*, which you can access from the **Compute** menu. Select the depth-area analysis you wish to rename by clicking on it in the list of current analyses. The selected analysis is highlighted after you select it. After you select an analysis you can press the **Rename...** button on the right side of the window. The *Rename Depth-Area Analysis* window (Figure 353) will open where you can provide the new name. If you wish you can also change the description at the same time. If the new description will be long, you can use the button to the right of the description field to open an editor. When you are satisfied with the name and description, press the **Rename** button to finish the process

of renaming the selected depth-area analysis. You cannot press the **Rename** button if no name is specified. If you change your mind and do not want to rename the selected depth-area analysis, press the **Cancel** button or the **X** button in the upper right of the *Rename Depth-Area Analysis* window to return to the *Depth-Area Analysis Manager* window.

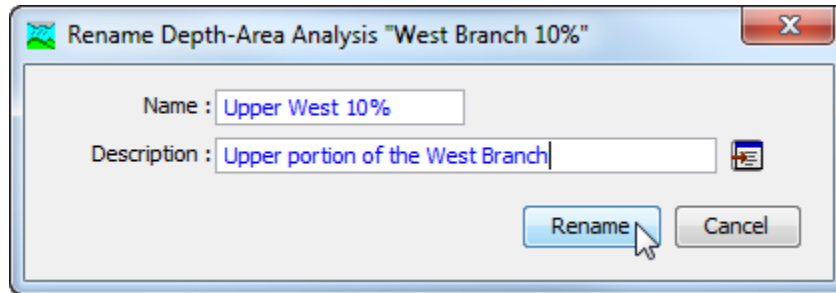

Figure 353. Renaming a depth-area analysis. This was accessed from the *Depth-Area Analysis Manager*.

The second way to rename is from the "Compute" tab of the *Watershed Explorer*. Select the depth-area analysis you wish to rename by clicking on it in the *Watershed Explorer*; it will become highlighted. Keep the mouse over the selected analysis and click the left mouse button again. The highlighted name will change to editing mode (Figure 354). You can then move the cursor with the arrow keys on the keyboard or by clicking with the mouse. You can also use the mouse to select some or all of the name. Change the name by typing with the keyboard. When you have finished changing the name, press the **Enter** key to finalize your choice. You can also finalize your choice by clicking elsewhere on the "Compute" tab. If you change your mind while in editing mode and do not want to rename the selected depth-area analysis, press the **Escape** key.

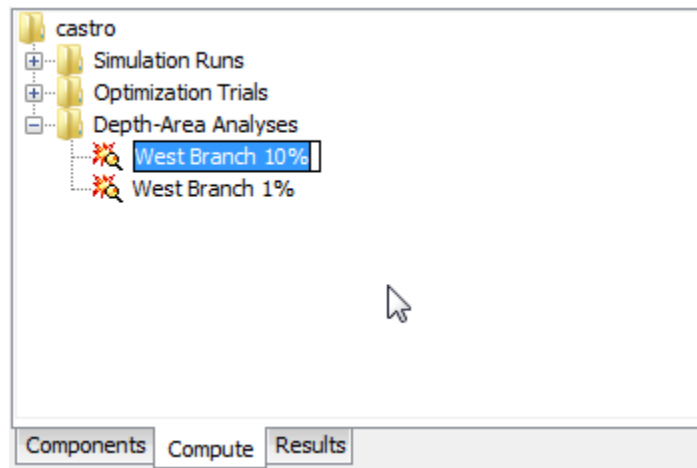

Figure 354. Renaming a depth-area analysis in the *Watershed Explorer*.



## Deleting a Depth-Area Analysis

There are two ways to delete a depth-area analysis. Both methods for deleting an analysis remove it from the project and automatically delete previously computed results. Once an analysis has been deleted it cannot be retrieved or undeleted.

The first way to perform a deletion is to use the *Depth-Area Analysis Manager*, which you can access from the **Compute** menu. Select the depth-area analysis you wish to delete by clicking on it in the list of current analyses. The selected analysis is highlighted after you select it. After you select an analysis you can press the **Delete** button on the right side of the window. A window will open where you must confirm that you wish to delete the selected analysis as shown in Figure 355. Press the **OK** button to delete the analysis. If you change your mind and do not want to delete the selected depth-area analysis, press the **Cancel** button or the **X** button in the upper right to return to the *Depth-Area Analysis Manager* window.

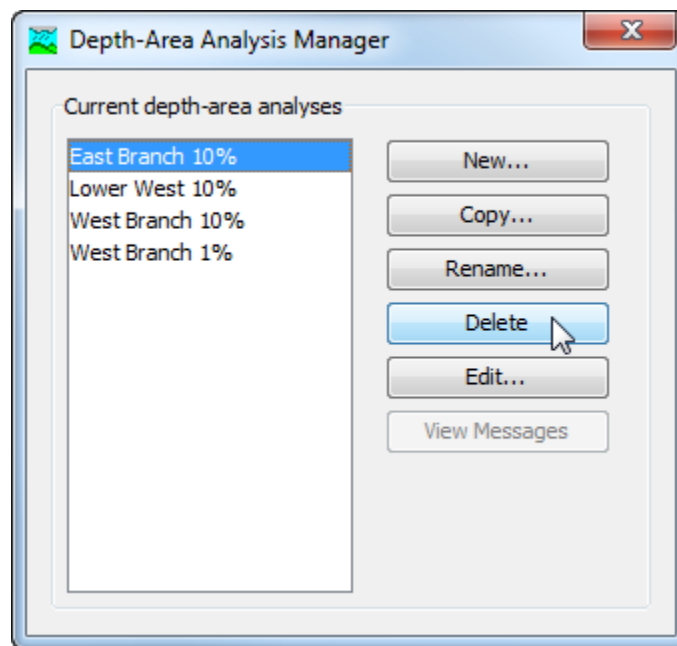

Figure 355. Preparing to delete a depth-area analysis from the *Depth-Area Analysis Manager*. A confirmation will be required after pressing the **Delete** button.

The second way to delete is from the "Compute" tab of the *Watershed Explorer*. Select the depth-area analysis you wish to delete by clicking on it in the *Watershed Explorer*; it will become highlighted (Figure 356). Keep the mouse over the selected analysis and click the right mouse button. A context menu is displayed that contains several choices including delete. Click the **Delete** command. A window will open where you must confirm that you wish to delete the selected analysis.

Press the **OK** button to delete the analysis. If you change your mind and do not want to delete the selected depth-area analysis, press the **Cancel** button or the **X** button in the upper right to return to the *Watershed Explorer*.

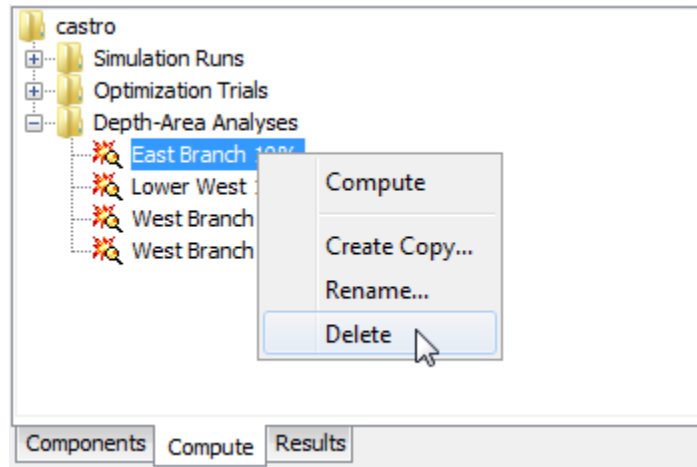

Figure 356. Deleting a depth-area analysis in the *Watershed Explorer*.

### Selecting a Simulation Run

One of the steps in the wizard for creating a new depth-area analysis is the selection of a simulation run. This type of analysis must use a meteorologic model with the frequency precipitation method. Only simulation runs where the run uses an appropriate meteorologic model will be shown.

Selecting the simulation run for a depth-area analysis after it has been created is accessed from the "Compute" tab of the *Watershed Explorer*. Click on the analysis node to display the *Component Editor* for the depth-area analysis. You may need to first click on the "Analyses" folder to expand it, then click on "Depth-Area Analyses" folder. The "Depth-Area Analysis" tab is shown along with the "Analysis Points" tab, as shown in Figure 357. The selection list shows all of the simulation runs that have an appropriate meteorologic model using the frequency precipitation method. You can also press the simulation run button next to the selection list to bring up a chooser. The chooser helps to make a selection by showing the description of each run.

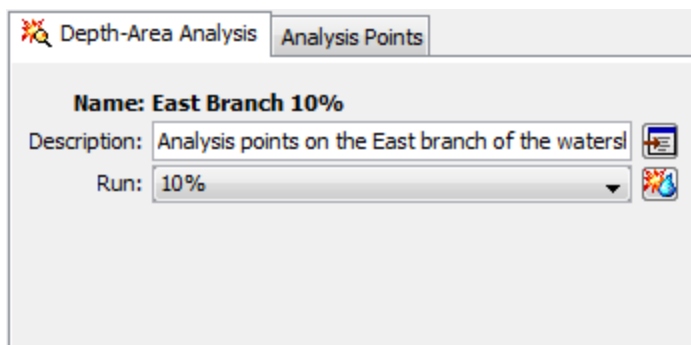

Figure 357. Selecting the simulation run used as the basis for the depth-area analysis.

### Selecting Analysis Points

Selecting analysis points is done after a depth-area analysis has been created using the wizard. Access the *Component Editor* for the analysis points from the "Compute" tab of the *Watershed Explorer*. Click on the analysis node to display the "Analysis Points" tab Figure 358. You may need to first click on the "Analyses" folder to expand it, and then click on the "Depth-Area Analyses" folder. The analysis points are selected in a table. All elements in the basin model from the underlying simulation run are available for selection. Select as many points as necessary by selecting from the list for each point. To discontinue using a specific point, change the selection for that point to "None."

 A screenshot of the same software interface as Figure 357, but showing a table with four rows. The table has two columns: "Analysis Point" and "Element". The rows are: Point 1 (East Branch), Point 2 (Outlet), Point 3 (Subbasin-2), and Point 4 (--None--).
 

Analysis Point	Element
Point 1	East Branch
Point 2	Outlet
Point 3	Subbasin-2
Point 4	--None--

Figure 358. Selecting analysis points for a depth-area analysis.

### Computing Results for an Analysis

Results for a depth-area analysis are generated by computing it. Changes in all the components used in the analysis are automatically tracked to determine if the results are current. When the results are no longer current, the analysis must be recomputed in order to refresh the results. Computing results begins with selecting a depth-area analysis.

## **Selecting a Current Depth-Area Analysis**

There are two ways to select the current depth-area analysis. Both methods set the analysis so that it can be computed and results can be accessed from the *Watershed Explorer* and the basin map as soon as they are available. The current depth-area analysis is shown in the title of the basin map.

The first way to select the current depth-area analysis is from the toolbar. The compute selection box shows all of the compute components in the project; depth-area analyses appear after forecast alternatives in the selection box. Each depth-area analysis in the selection box includes the prefix `Depth-Area` followed by the name of the analysis. Click on the toolbar selection box and choose a depth-area analysis to become the current analysis.

The second way to select the current depth-area analysis is from the *Watershed Explorer*, on the "Compute" tab. Select the depth-area analysis you wish to become the current analysis by clicking on it in the *Watershed Explorer*. The depth-area analyses are listed alphabetically in the "Depth-Area Analyses" folder.

## **Computing a Depth-Area Analysis**

There are three ways to compute the currently selected depth-area analysis. All methods automatically perform parameter checking, and if no errors are generated, proceed to the actual computing of depth-area analysis results. Additionally, the program is designed to be computationally efficient. Only components with data changes since the last compute will be recomputed; the remainder of the components have not changed so previous analysis results are still applicable. If you wish, you may force all components to be recomputed regardless of data changes since the last compute.

The first way to compute a depth-area analysis is from the **Compute** menu. Click on the **Compute** menu and then select the **Compute Depth-Area** command. The name of the current depth-area analysis is shown in brackets as part of the menu command. If the command is not available, it is because there is no current depth-area analysis; you must first select an analysis. A window will automatically open that shows the progress of the compute. You will need to manually close the window when the compute is done, whether it failed or was successful. If you wish to force all components to be recomputed instead of just those with data changes, hold the *control* key while selecting the menu command.

The second way to compute a depth-area analysis is from the *Watershed Explorer*, on the "Compute" tab. Select the depth-area

analysis you wish to compute by clicking on it in the *Watershed Explorer* with the right mouse button. A context menu is displayed that contains several choices including compute. Click the **Compute** command. The progress window will automatically open. If you wish to force all components to be recomputed instead of just those with data changes, hold the *control* key while selecting the right mouse menu command.

The third way to compute a depth-area analysis is from the toolbar. The compute button is enabled whenever there is a current analysis that can be computed. If the button is not available or shows a different type of compute, you must first select a depth-area analysis. Press the button to compute the current depth-area analysis. The progress window will automatically open. If you wish to force all components to be recomputed instead of just those with data changes, hold the *control* key while selecting the toolbar button.

### **Computing Multiple Analyses**

Multiple depth-area analysis can be computed in rapid succession. Each analysis included for simulation is internally managed the same as if it were computed in isolation. The steps automatically performed for the user begin with selecting the depth-area analysis, checking parameters for the analysis, and finally computing the simulation. This sequence is repeated in rapid succession for each depth-area analysis in the selected set. Appropriate feedback is provided through a progress bar.

The multiple depth-area analyses must exist before they can be selected for a multiple compute. Select the **Multiple Compute** command on the **Compute** menu. A manager is used to select depth-area analyses (Figure 359). Make selections in the list and then press the **Compute** button to begin computing the selected analyses. A separate progress bar will be displayed for each depth-area analysis as it is computed. The progress bar may disappear automatically at the conclusion of a depth-area analysis depending on the configurations in the *Program Settings*. If errors are encountered while computing an analysis, the progress bar will always remain visible after all selected analyses have finished computing regardless of any other settings.

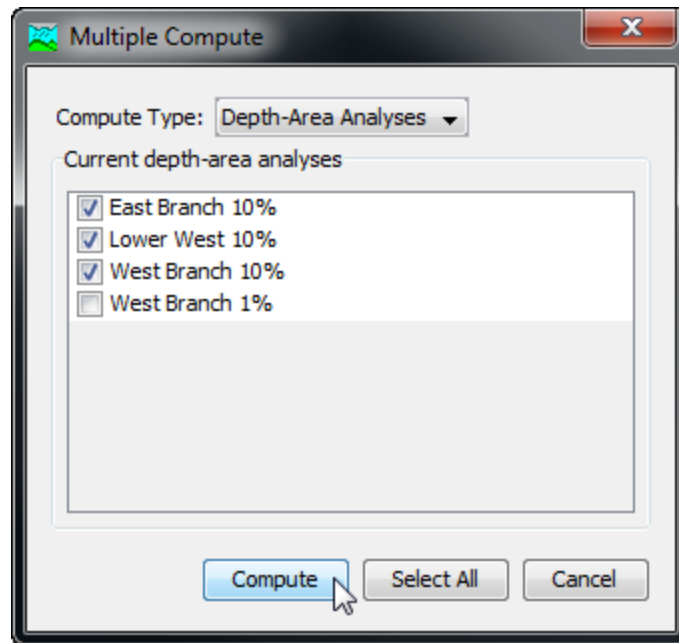

Figure 359. Selecting multiple depth-area analyses for sequential compute.

## Viewing Results for the Current Analysis

A variety of graphical and tabular results are available after a depth-area analysis is computed. The same results are also available for the current analysis, so long as no data used in the analysis has changed. The program tracks all of the data in the depth-area analysis and selected simulation run on which it is based. It further tracks all of the data used in the basin model, meteorologic model, and control specifications used in the simulation run that is the basis of the depth-area analysis. Results for a depth-area analysis are only available when none of this data has changed since the last time the analysis was computed. If any of the data has changed, you will need to recompute the depth-area analysis before you will be allowed to view results.

Once a result is open for viewing it will remain open until it is closed by the user. It is possible that data used during the simulation that produced the result could change while the result is open for viewing. In this case, the open result will immediately show an indication that data has changed and the depth-area analysis needs to be recomputed. After the depth-area analysis is recomputed the open results are automatically updated with the new results and the indication is updated with the data and time of the most-recent compute.

## Peak Flow Summary Table

The peak flow summary table shows certain information such as the depth-area analysis name, underlying simulation run name, and component names in the underlying simulation run. The principal information is a table that includes one row for each analysis point. Columns are provided that give the name of the analysis point, drainage area, peak flow, and time of peak flow. The data is obtained by extracting results from the simulation that is performed for each analysis point. The peak flow summary table is accessed from the Results menu. When the Basin Map is open and a depth-area analysis is selected, choose the Peak Flow Summary command to view the results. Sample results are shown in Figure 360.

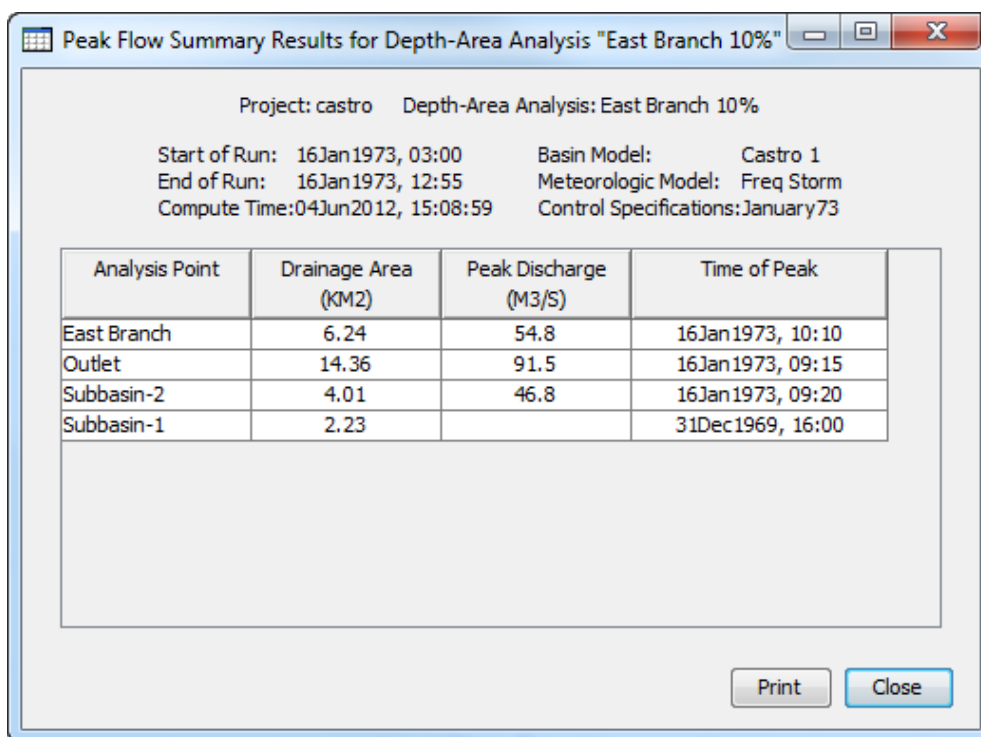

Project: castro    Depth-Area Analysis: East Branch 10%

Start of Run: 16Jan1973, 03:00    Basin Model: Castro 1  
 End of Run: 16Jan1973, 12:55    Meteorologic Model: Freq Storm  
 Compute Time: 04Jun2012, 15:08:59    Control Specifications: January73

Analysis Point	Drainage Area (KM2)	Peak Discharge (M3/S)	Time of Peak
East Branch	6.24	54.8	16Jan1973, 10:10
Outlet	14.36	91.5	16Jan1973, 09:15
Subbasin-2	4.01	46.8	16Jan1973, 09:20
Subbasin-1	2.23		31Dec1969, 16:00

Print    Close

Figure 360. Peak flow summary table showing the computed peak flow for each analysis point. Results correspond to the hypothetical storm with an area matched to the drainage area.

## Individual Elements

There are three ways to access results for individual elements in the current depth-area analysis. All methods show the same results. You must select one or more elements in the basin map before you can view results for that element. However, not all elements in the basin map may have results. The depth-area analysis is based on a simulation run that uses a specific basin model. The depth-area analysis works with selected analysis points. The results are separate

for each analysis point. Results for an analysis point are only computed at the elements upstream of that analysis point; all other elements in the basin model will have no results for that analysis point. When an element is upstream of more than one analysis point, you will need to indicate the analysis point for which results are desired.

The first method for viewing individual element results is to use the **Results** menu. You may need to first open the basin model by clicking on it in the *Watershed Explorer*, on the "Components" tab. The current depth-area analysis is shown in brackets in the basin map title bar. Choose the analysis point for which results will be viewed, by selecting from the **Results** ⇒ **Select Point** menu. The currently selected analysis point is shown in brackets in the menu. Next select one or more elements in the basin map by clicking with the arrow tool. With an element selected in the basin map, click the **Results** menu and select the **Element Graph** command, the **Element Summary Table** command, or the **Element Time-Series Table** command. The appropriate result will automatically be shown in the *Desktop* area. The information included in the graph (Figure 361) varies by element type, but always includes outflow. Optional items such as observed flow, computed stage, and observed stage are also included.



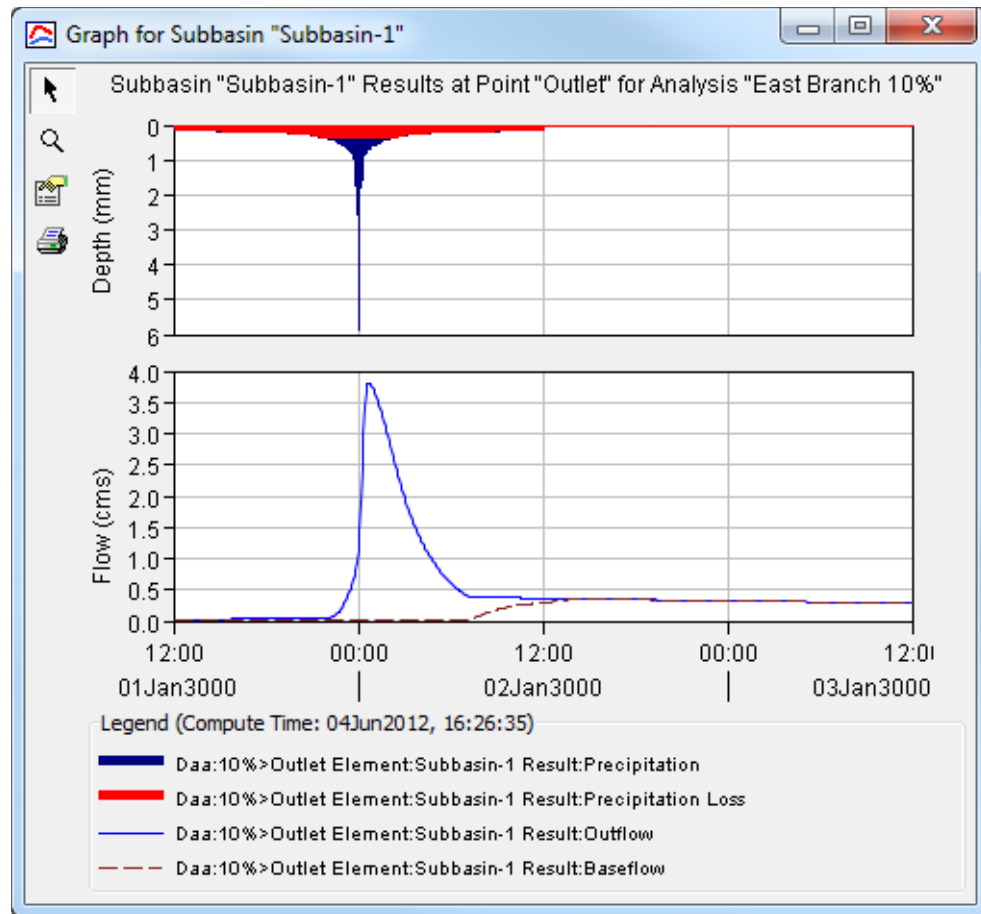

Figure 361. Element graph for a subbasin after a depth-area analysis.

The information included in the summary table (Figure 362) also varies by element type but always includes the peak flow, time of peak flow, and outflow volume. The time-series table (Figure 363) includes the same information as the graph but in numerical format. If you selected more than one element, then one result for each element will open. The menu commands on the **Results** menu will only be enabled if the results for the current depth-area analysis do not need to be recomputed, and an analysis point has been selected on the **Results** menu.

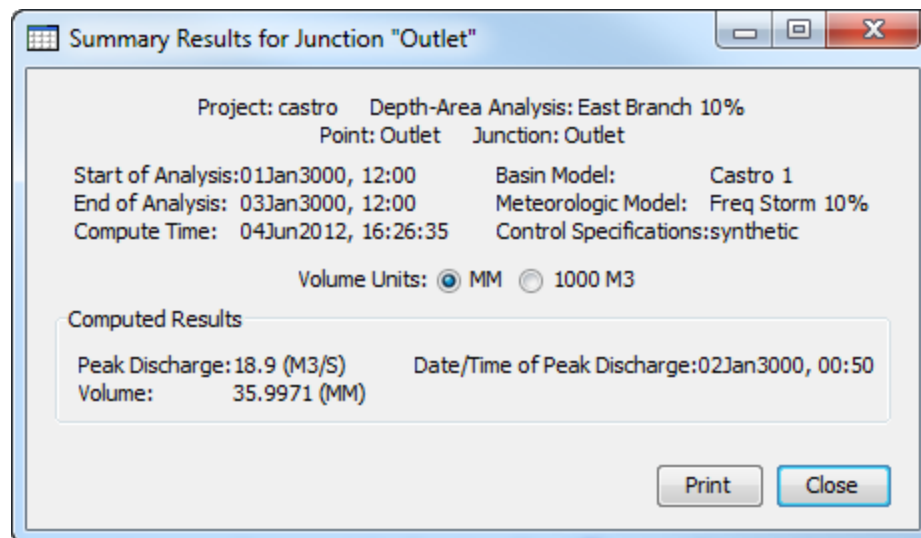

Figure 362. Element summary table for a junction after a depth-area analysis. The junction is also an analysis point.

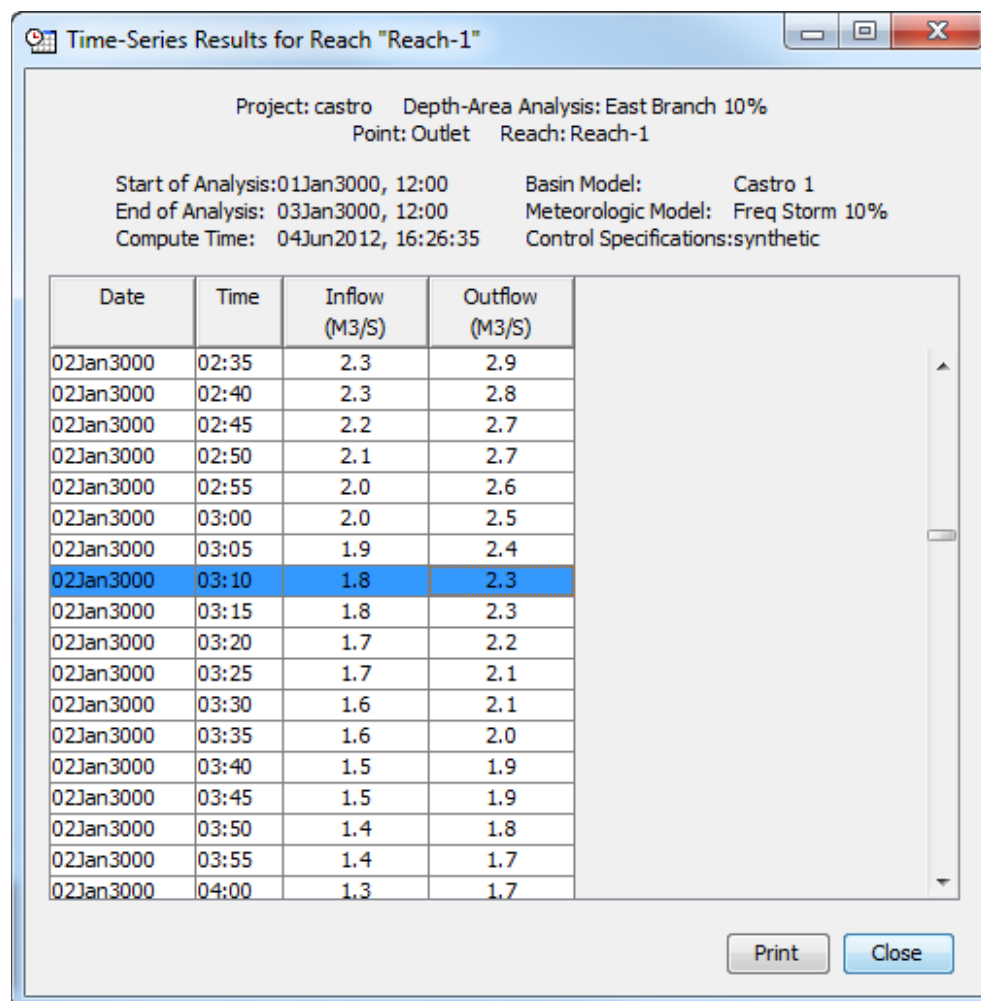

Figure 363. Element time-series table for a reach after a depth-area analysis.

The second method for viewing individual element results is to use the element icon in the basin map. Again you may need to open the basin model before attempting to view results. You may also need to choose the analysis point for which results will be viewed, by selecting from the **Results** ⇒ **Select Point** menu. Finally, click on an element to highlight it. Keep the mouse over the element and press the right mouse button. A context menu is displayed that contains several choices including **View Results**. The name of the current depth-area analysis is shown in brackets after the menu command. Move the mouse into the **View Results** submenu and select any of the result commands: **Graph**, **Summary Table**, or **Time-Series Table**. The appropriate result will open. If you selected more than one element, then one result will open for each element. The **View Results** menu command will only be enabled if the results for the current depth-area analysis do not need to be recomputed, and an analysis point has been selected on the **Results** menu.

The third method for viewing individual element results is to use the buttons on the toolbar. First you must open the basin model, select a current analysis point on the **Results** menu, and finally select one or more elements in the basin map by clicking with the arrow tool. Once you have a selected element, click the graph, summary table, or time-series table buttons. The button for selecting a graph shows a line plot. The button for the summary table shows a plain table. The button for the time-series table shows a table plus a clock. The appropriate result will automatically open. If you selected more than one element, then one result for each element will be added to the *Desktop*. The toolbar buttons for viewing element results will only be enabled if the results for the current depth-area analysis do not need to be recomputed, and there is an element selection in the basin map, and the selected element is upstream of the analysis point selected on the **Results** menu.

## **Viewing Results for Other Analyses**

In addition to viewing results for the currently selected depth-area analysis, it is also possible to view results for other analyses that are not the current selection. However, those other analyses are also tracked in the same way as the current depth-area analysis to make sure data has not changed and results do not need to be recomputed. If any of the data in a depth-area analysis changes, it will have to be recomputed before results can be viewed. Results for other depth-area analyses are accessed from the *Watershed Explorer*, on the "Results" tab.

To begin viewing results, go to the "Results" tab of the *Watershed Explorer* and click on the desired depth-area analysis icon. If

necessary, click on the "Depth-Area Analyses" folder to expand it and view the analyses in the project. The depth-area analysis icon will be disabled if any data used in the analysis has changed and results need to be recomputed. If any result is open at the time data changes, the affected results will be automatically updated.

### **Peak Flow Summary Table**

The peak flow summary table can be accessed by clicking on the "Peak Flow Summary" node in the *Watershed Explorer* (Figure 364). The table will be displayed. It is exactly the same table that can be viewed for the current depth-area analysis.

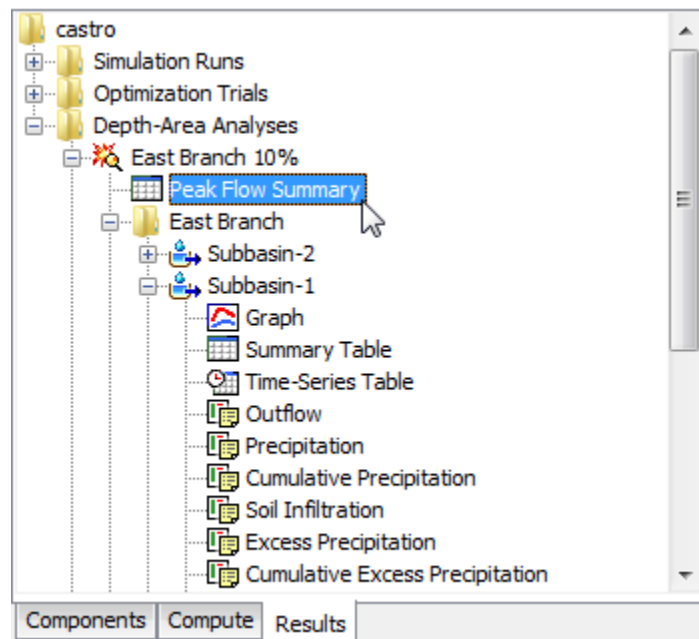

Figure 364. Viewing depth-area analysis results in the *Watershed Explorer*. The results for each analysis point are also shown in addition to analysis results.

### **Individual Elements**

Each analysis point is shown as a folder in the *Watershed Explorer* under the depth-area analysis node. The folder for each analysis point includes all of the elements above that analysis point. The results for each element are accessed by clicking on its node. The first item listed for each element is the graph; click on the "Graph" node to view the result (Figure 364). It is exactly the same graph that can be viewed for the current depth-area analysis. The information included in the graph varies by element type but always includes outflow. Optional items such as observed flow, computed stage, and observed stage are also included. Similarly, the summary table and time-series table can

also be accessed by clicking on the "Summary Table" or "Time-Series Table" node, respectively.

### ***Element Time-Series Preview Graph***

All of the time-series data computed by an individual element are available for viewing. The time-series data are listed under each element node in the *Watershed Explorer*. The first node under each element is the graph, followed by the summary table and time-series table. The remaining nodes for each element represent the different time-series data. Click on a time-series node to preview the data in the *Component Editor*. You may select multiple time-series data by holding the shift or control key while using the mouse to click on additional nodes (Figure 365). The selected time-series may come from different elements above the same analysis point, the same element for different analysis points, or different elements in different analyses. Results can also be combined from simulation runs, optimization trials, and depth-area analyses. The selected time-series data will automatically be partitioned into groups by data type.

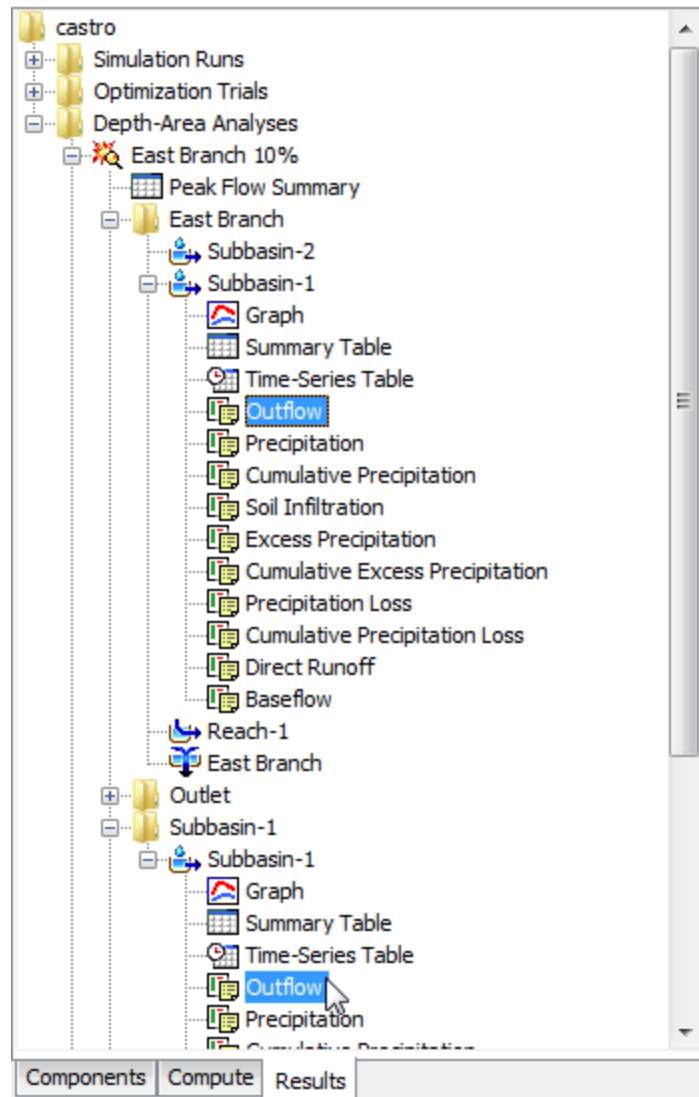

Figure 365. Viewing depth-area analysis results in the Watershed Explorer. Two results were selected at the same element in one analysis, for two different analysis points; results could have been combined from multiple elements, analysis points, or analyses.

### Time-Series Tables and Graphs

Preview graphs of selected time-series data can be opened as graphs or time-series tables within the *Desktop* area. Begin by selecting the time-series you wish to include in the graph or table. Once you have selected the desired time-series, you can press the graph or time-series table buttons on the toolbar. The chosen time-series will be graphed or tabulated (Figure 366).

After you have opened a time-series table or graph, you may add additional time-series results. Position the mouse over the time-series result you wish to add to the graph or table. Press and hold the left

mouse button and then drag the mouse over the top of the graph or table where you want the result to be added. The mouse cursor will change to indicate which tables and graphs can accept the additional time-series. Release the mouse button while it is over the desired table or graph and it will be automatically updated to show the additional time-series results.

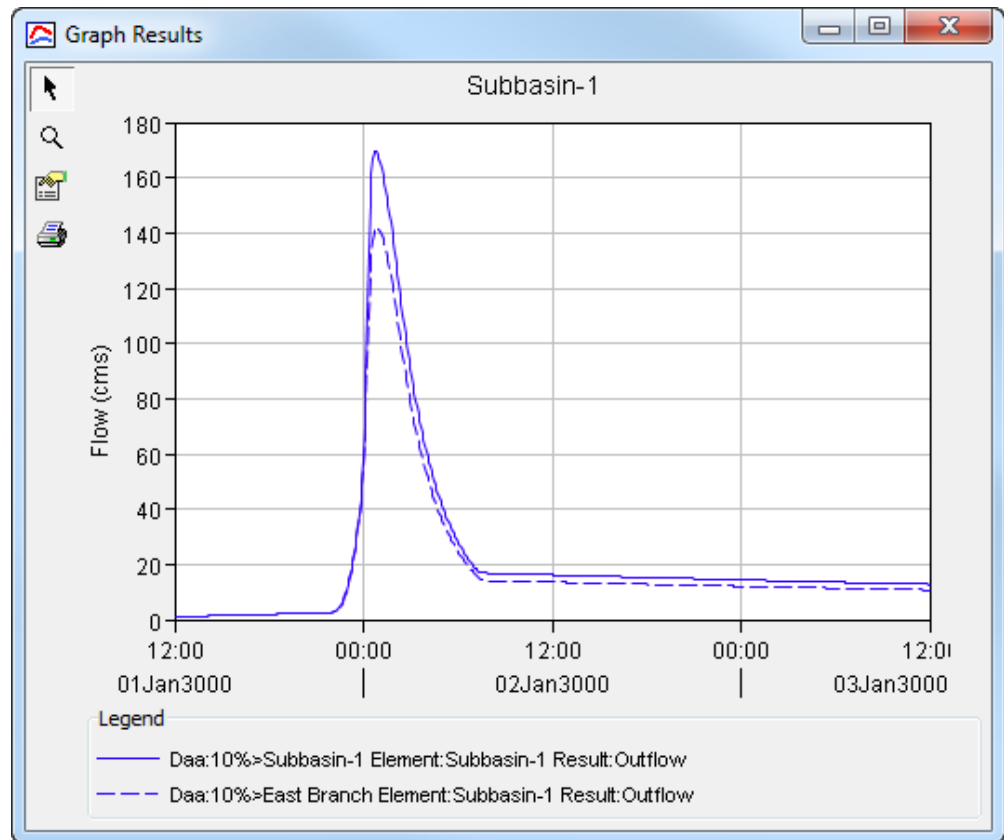

Figure 366. Comparing results from the same element at two different analysis points. The depth-area reduction factor changes due to different drainage area at the two analysis points.

## Changing Graph Properties

All of the graphs open with default properties for line color, line style, data symbols, etc. These default properties have been selected to be appropriate for most situations. However, it is possible to customize the properties in a graph. To change the properties, first click on the graph to select it. Next go to the **Results** menu and select the **Graph Properties...** command. An editor will open that can be used to change the properties of the selected graph. The properties for each time-series curve can be changed. It is also possible to change the properties for the axis, title, gridlines, patterns, and legend. The editor used to change properties is the same as used for simulation run graphs shown in Figure 294.

This Page Left Blank



## CHAPTER 16

# ***Assessing Model Uncertainty***

It is widely known that hydrology models are rarely capable of perfectly simulating the watershed response. The difference between the simulated response and the actual observed response is termed uncertainty and may range from very small to excessively large. The uncertainty is usually due to a combination of factors including inadequate meteorologic data, incongruities in model representation of physical processes, and errors in identifying model parameter values. To a lesser degree, errors in observing the watershed response may also contribute to model uncertainty. A quantitative assessment of the model uncertainty is a key component of determining the reliability of the model predictions and critical to using the predictions with risk-based engineering methodologies.

### ***Uncertainty Analyses***

Uncertainty assessment is the process of determining the total error in the simulated watershed response, for example, the flow at the outlet. The simulated flow at the outlet actually depends on many individual components each with its own error. There is error in the meteorologic data because it is generally impossible to accurately measure precipitation at the same spatial and temporal scale as the land surface processes. There is error in the models of the hydrologic processes because it is generally impossible to include every possible process at the scale it occurs, for example, animal burrows or plant transpiration. There is error in the model parameter values because the equations are solved at a scale ranging from meters up to whole subbasins and area-average values must be used. The error in the whole watershed response includes all of these individual errors and the complex way in which they interact.

The watershed model is very complex and it may not be possible to attribute the total error to individual components. An error in the precipitation data may be compensated with a corresponding error in the infiltration parameter values. An error in the mathematical formulation of the infiltration or transpiration process may be compensated with a corresponding error in the parameter values. An assumption about process scale may lead to effective area-averaged parameter values that do not match values that would be measured in the field. It is usually not possible to determine the exact error in each

component or how the errors are interacting and accumulating throughout the watershed model.

The error in an individual model parameter may be described with a probability density function (PDF) during an uncertainty assessment. In one case the selected process model is well-suited to the watershed, the input to the model is accurate, and the parameters can be estimated from field observations. In this first case there is very little uncertainty in the parameter value. In another case the model is missing important subtleties of the physical process, the input is poor, and parameter estimation is difficult. In this second case there is a high degree of uncertainty in the parameter value. In both cases, a PDF can be parameterized to reflect the uncertainty in the parameter, either small or large. Different model parameters require different formulations of the PDF and they may change from one watershed to another or from one historical time period to another.

The Monte Carlo method is one approach to estimating the uncertainty in the simulated watershed response given the uncertainty in each of the model parameters. The Monte Carlo method works by creating many alternative models of the watershed using an automated sampling procedure. Each sample is created by sampling the model parameters according to their individual probability density function (PDF). Each sample is simulated to obtain a watershed response corresponding to the sampled parameter values. All of the responses from all of the samples can be analyzed statistically to evaluate the uncertainty in the simulated watershed response. The program uses the Monte Carlo method to perform the uncertainty assessment.

Within HEC-HMS, uncertainty analyses are one of the simulation components that can compute results. Each analysis is composed of a basin model, meteorologic model, and time control information. The analysis also includes a selection of parameters to be evaluated and a description of the uncertainty for each parameter. Several options are provided for how the uncertainty is described for each parameter. A variety of results graphs are available from the *Watershed Explorer* for assessing the uncertainty in simulated watershed response.

The uncertainty analysis available in Version 4.1 primarily addresses the uncertainty in hydrologic model parameters which may be due to incorrect model selection, parameter estimation, scale, or other problems. The user must identify each uncertain parameter during the assessment and describe the uncertainty using an appropriate PDF. Uncertainty in the meteorologic data is not specifically addressed within the program. Evaluation of uncertainty in meteorology must be carried out using an assessment framework that integrates meteorologic and hydrologic uncertainty. HEC is currently developing the HEC-WAT modeling framework to be capable of carrying out such

an integrated assessment. The uncertainty analysis in HEC-HMS is designed to work with HEC-WAT with expanded integration capabilities planned for future releases.

### **Creating a New Uncertainty Analysis**

A new uncertainty analysis is created using a wizard that helps you navigate the steps to creating a new analysis. There are two ways to access the wizard. The first way to access the wizard is to click on the **Compute** menu and select the **Create Compute ⇒ Uncertainty Analysis** command; it is only enabled if at least one basin model and meteorologic model exist. The wizard will open and begin the process of creating a new uncertainty analysis. The second way to access the wizard is from the *Uncertainty Analysis Manager*. Click on the **Compute** menu and select the **Uncertainty Analysis Manager** command. The *Uncertainty Analysis Manager* will open and show any analyses that already exist. Press the **New...** button to access the wizard and begin the process of creating an uncertainty analysis, as shown in Figure 367.

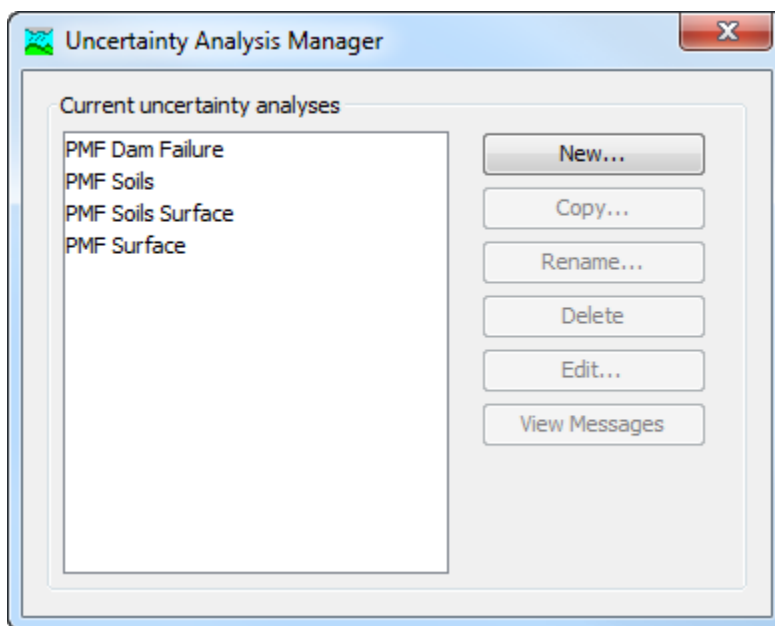

Figure 367. Beginning the process of creating a new uncertainty analysis using the *Uncertainty Analysis Manager*.

The first step of creating an uncertainty analysis is to provide the name for the new analysis (Figure 368). A default name is provided for the new uncertainty analysis; you can use the default or replace it with your own choice. After you finish creating the analysis you can add a description to it. If you change your mind and do not want to create a new uncertainty analysis, you can press the **Cancel** button at the bottom of the wizard or the **X** button in the upper right corner of the

wizard. The **Cancel** button can be pressed at any time you are using the wizard. Press the **Next>** button when you are satisfied with the name you have entered and are ready to proceed to the next step.

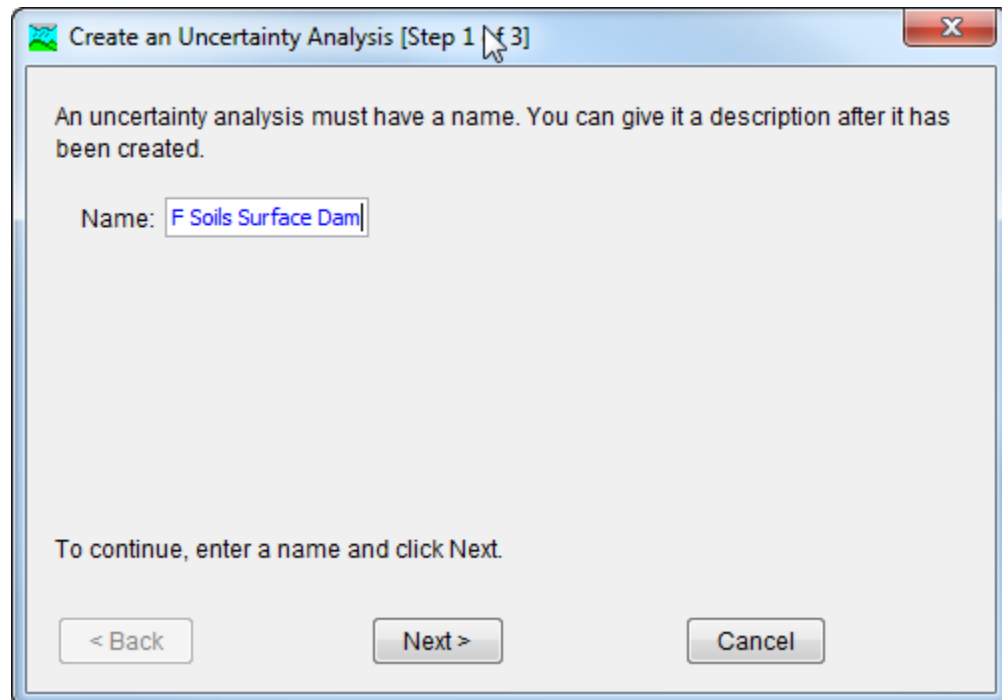

Figure 368. Entering a name for a new uncertainty analysis. The remaining steps are to select a basin model and a meteorologic model.

The second step of creating an uncertainty analysis is to select a basin model. All of the basin models that are currently part of the project are displayed in alphabetical order. By default the first basin model in the table is selected. The selected basin model is highlighted. You can use your mouse to select a different basin model by clicking on it in the table of available choices. You can also use the arrow keys on your keyboard to select a different basin model. Press the **Next>** button when you are satisfied with the basin model you have selected and are ready to proceed to the next step. Press the **<Back** button if you wish to return to the previous step and change the name for the new uncertainty analysis.

The third step of creating an uncertainty analysis is to select a meteorologic model. All of the meteorologic models that are currently part of the project are displayed in alphabetical order. By default the first meteorologic model in the table is selected. The selected meteorologic model is highlighted. You can use your mouse to select a different meteorologic model by clicking on it in the table of available choices. You can also use the arrow keys on your keyboard to select a different meteorologic model. You are responsible for selecting a basin model in step two and a meteorologic model in this step that will

successfully combine to compute results. Press the **Finish** button when you are satisfied with the name you have entered, the basin model and meteorologic model you selected, and are ready to create the uncertainty analysis. Press the **<Back** button if you wish to return to the previous step and select a different basin model.

### ***Copying an Uncertainty Analysis***

There are two ways to copy an uncertainty analysis. Both methods for copying an analysis create an exact duplicate with a different name. Once the copy has been made it is independent of the original and they do not interact.

The first way to create a copy is to use the *Uncertainty Analysis Manager*, which is accessed from the **Compute** menu. Select the uncertainty analysis you wish to copy by clicking on it in the list of current uncertainty analyses. The selected analysis is highlighted after you select it. After you select an analysis you can press the **Copy...** button on the right side of the window. The *Copy Uncertainty Analysis* window (Figure 369) will open where you can name and describe the copy that will be created. A default name is provided for the copy; you can use the default or replace it with your own choice. A description can also be entered; if it is long you can use the button to the right of the description field to open an editor. When you are satisfied with the name and description, press the **Copy** button to finish the process of copying the selected uncertainty analysis. You cannot press the **Copy** button if no name is specified. If you change your mind and do not want to copy the selected uncertainty analysis, press the **Cancel** button or the **X** button in the upper right to return to the *Uncertainty Analysis Manager* window.

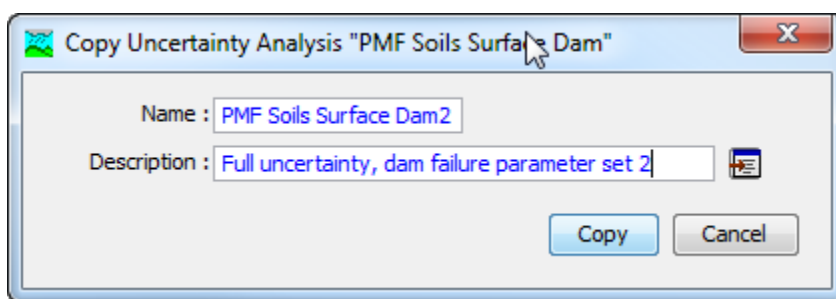

Figure 369. Creating a copy of an uncertainty analysis.

The second way to copy is from the "Compute" tab of the *Watershed Explorer*. Move the mouse over the uncertainty analysis you wish to copy and press the right mouse button (Figure 370) A context menu is displayed that contains several choices including copy. Click the **Create Copy...** command. The *Copy Uncertainty Analysis* window will open where you can name and describe the copy that will be created. A default name is provided for the copy; you can use the default or

replace it with your own choice. A description can also be entered; if it is long you can use the button to the right of the description field to open an editor. When you are satisfied with the name and description, press the **Copy** button to finish the process of copying the selected uncertainty analysis. You cannot press the **Copy** button if no name is specified. If you change your mind and do not want to copy the selected uncertainty analysis, press the **Cancel** button or the **X** button in the upper right of the *Copy Uncertainty Analysis* window to return to the *Watershed Explorer*.

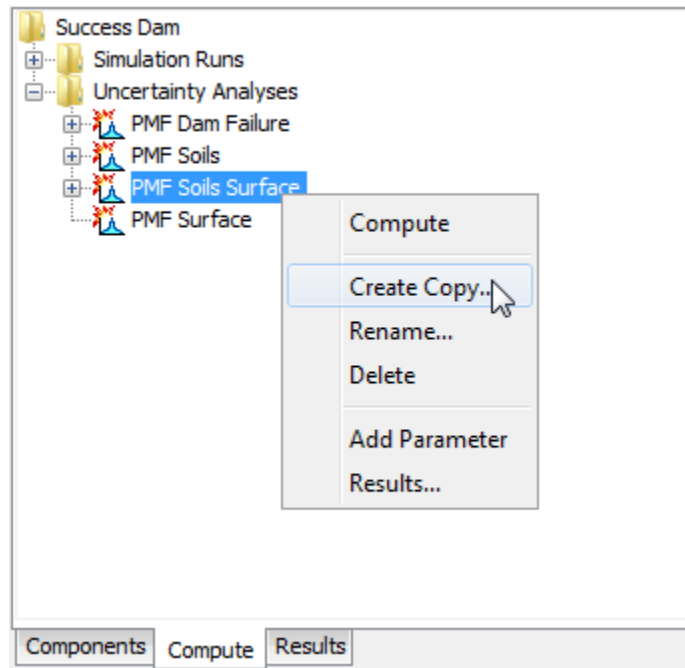

Figure 370. Copying an uncertainty analysis from the Watershed Explorer. The *Copy Uncertainty Analysis* window will appear after the **Create Copy** menu command is selected.

## Renaming an Uncertainty Analysis

There are two ways to rename an uncertainty analysis. Both methods for renaming an analysis change its name and perform other necessary operations.

The first way to perform a rename is to use the *Uncertainty Analysis Manager*, which you can access from the **Compute** menu. Select the uncertainty analysis you wish to rename by clicking on it in the list of current analyses. The selected analysis is highlighted after you select it. After you select an analysis you can press the **Rename...** button on the right side of the window. The *Rename Uncertainty Analysis* window (Figure 371) will open where you can provide the new name. If you wish you can also change the description at the same time. If the new description will be long, you can use the button to the right of

the description field to open an editor. When you are satisfied with the name and description, press the **Rename** button to finish the process of renaming the selected uncertainty analysis. You cannot press the **Rename** button if no name is specified. If you change your mind and do not want to rename the selected uncertainty analysis, press the **Cancel** button or the **X** button in the upper right of the *Rename Uncertainty Analysis* window to return to the *Uncertainty Analysis Manager* window.

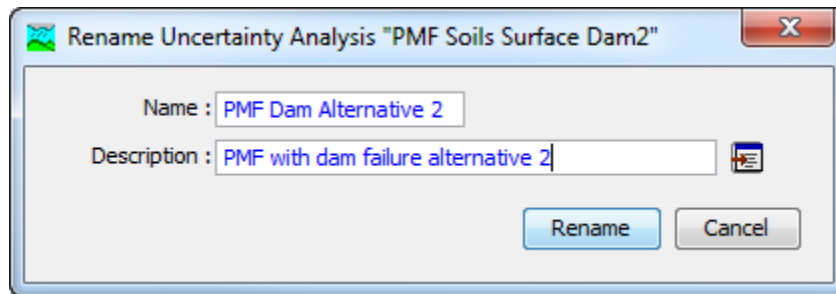

Figure 371. Renaming an uncertainty analysis. This was accessed from the *Uncertainty Analysis Manager*.

The second way to rename is from the "Compute" tab of the *Watershed Explorer*. Select the uncertainty analysis you wish to rename by clicking on it in the *Watershed Explorer*; it will become highlighted. Keep the mouse over the selected analysis and click the left mouse button again. The highlighted name will change to editing mode (Figure 372). You can then move the cursor with the arrow keys on the keyboard or by clicking with the mouse. You can also use the mouse to select some or all of the name. Change the name by typing with the keyboard. When you have finished changing the name, press the **Enter** key to finalize your choice. You can also finalize your choice by clicking elsewhere on the "Compute" tab. If you change your mind while in editing mode and do not want to rename the selected uncertainty analysis, press the **Escape** key.

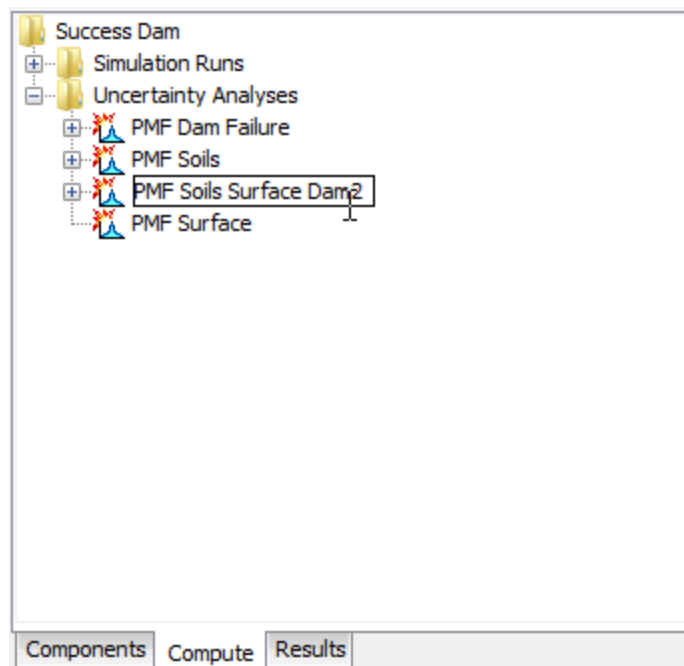

Figure 372. Renaming an uncertainty analysis in the Watershed Explorer.

### ***Deleting an Uncertainty Analysis***

There are two ways to delete an uncertainty analysis. Both methods for deleting an analysis remove it from the project and automatically delete previously computed results. Once an analysis has been deleted it cannot be retrieved or undeleted.

The first way to perform a deletion is to use the *Uncertainty Analysis Manager*, which you can access from the **Compute** menu. Select the uncertainty analysis you wish to delete by clicking on it in the list of current analyses. The selected analysis is highlighted after you select it. After you select an analysis you can press the **Delete** button on the right side of the window. A window will open where you must confirm that you wish to delete the selected analysis as shown in Figure 373. Press the **OK** button to delete the analysis. If you change your mind and do not want to delete the selected uncertainty analysis, press the **Cancel** button or the **X** button in the upper right to return to the *Uncertainty Analysis Manager* window.



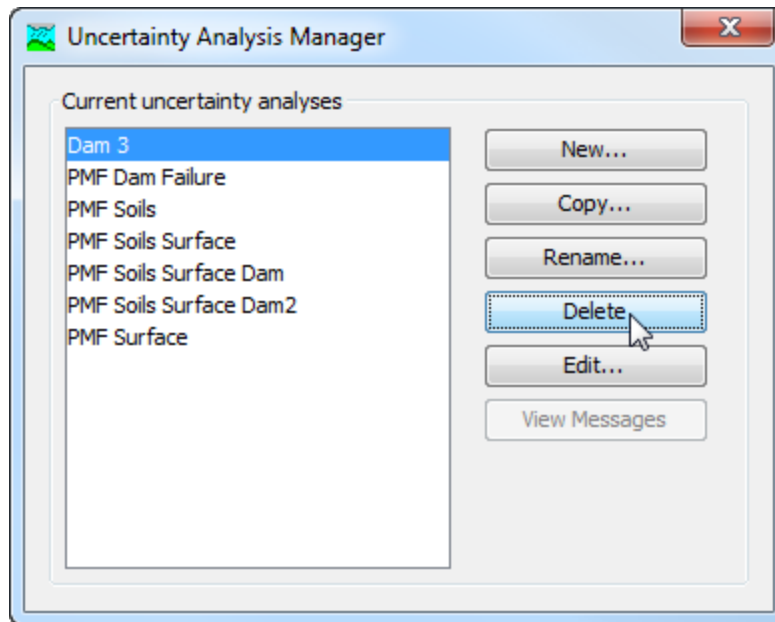

Figure 373. Preparing to delete an uncertainty analysis from the *Uncertainty Analysis Manager*. A confirmation will be required after pressing the **Delete** button.

The second way to delete is from the "Compute" tab of the *Watershed Explorer*. Select the uncertainty analysis you wish to delete by clicking on it in the *Watershed Explorer*; it will become highlighted (Figure 374). Keep the mouse over the selected analysis and click the right mouse button. A context menu is displayed that contains several choices including delete. Click the **Delete** command. A window will open where you must confirm that you wish to delete the selected analysis. Press the **OK** button to delete the analysis. If you change your mind and do not want to delete the selected uncertainty analysis, press the **Cancel** button or the **X** button in the upper right to return to the *Watershed Explorer*.

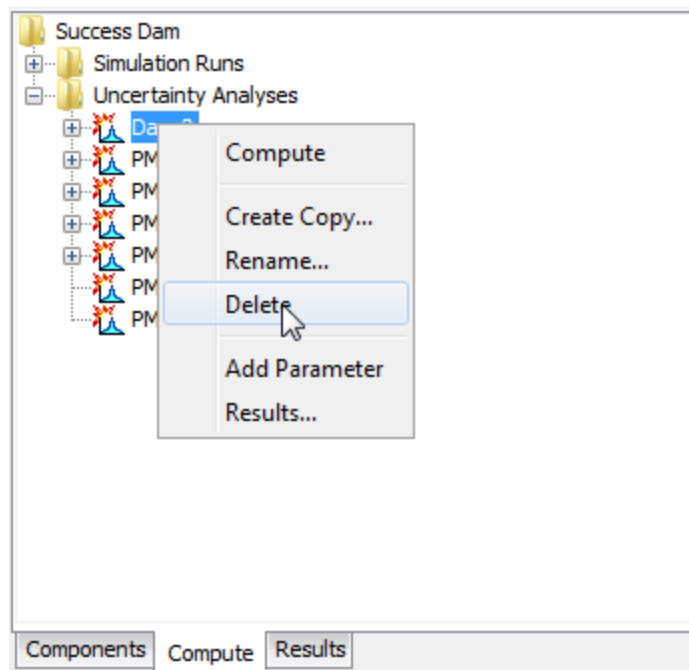

Figure 374. Deleting an uncertainty analysis in the Watershed Explorer.

### Selecting Components

One of the principal tasks when creating an uncertainty analysis using the wizard is the selection of the components that will be used to compute uncertainty results. The components include the basin model and the meteorologic model. These components are selected when creating a new uncertainty analysis with the wizard. However, you can change the basin model and meteorologic model you wish to use at any time using the *Component Editor* for the uncertainty analysis. Access the *Component Editor* from the "Compute" tab of the *Watershed Explorer* (Figure 375). If necessary, click on the "Uncertainty Analyses" folder to expand it and view the available uncertainty analyses. The *Component Editor* contains a basin model selection list that includes all of the basin models in the project. The *Component Editor* also contains a meteorologic model selection list that includes all of the meteorologic models in the project.

Figure 375. The uncertainty analysis component editor can be used to change the selected components, time window, and total number of samples.

### Entering a Time Window

You must enter a start date and time and an end date and time for the uncertainty analysis. The time control information is not specified in the wizard used to create the uncertainty analysis. The time control information must be entered after the analysis is created using the *Component Editor* for the uncertainty analysis (Figure 375). Enter the start date using the indicated format for numeric day, abbreviated month, and four-digit year. Enter the end date using the same format. The start time and end time are entered using a 24-hour time format.

### Total Samples and Convergence

You must enter the total number of samples for the uncertainty analysis. The number of samples is not specified in the wizard used to create the uncertainty analysis. The total samples must be entered after the analysis is created using the *Component Editor* for the uncertainty analysis (Figure 375). The number of samples specifies how many times the model parameters will be sampled during the uncertainty assessment.

The total number of samples must be large enough to accurately estimate the uncertainty in the watershed response. The process of determining when the watershed response has been accurately estimated is called convergence. Convergence is achieved when statistical measures of the watershed response do not change if more samples are computed. For example, one watershed response that is

often considered is the maximum pool elevation in a reservoir. The maximum pool elevation can be recorded for each sample and the mean value can be computed over all samples. Convergence in the mean maximum pool elevation is achieved when increasing the number of samples does not result in a change in the computed mean. If the standard deviation in the maximum pool elevation were considered, then additional samples would have to be computed until the computed standard deviation did not change. Fewer samples are required to estimate the mean watershed response compared to the standard deviation in the response.

The user must select an appropriate number of samples to compute for the uncertainty analysis. The number of samples required to achieve convergence depends on many factors including how a watershed is modeled as well as which watershed response statistics are considered. Automatic convergence criteria are not available at this time but are planned for a future release.

### ***Adding and Deleting Parameters***

The parameters that will be sampled during the uncertainty assessment may be at any subbasin, reach, or reservoir element in the basin model. Parameters that can be chosen for sampling are a selected set of the canopy, surface, lossrate, transform, and baseflow parameters in the subbasin element. Selected parameters can also be chosen for sampling from the routing parameters in the reach and from the components in the reservoir. Two types of parameters can be selected for sampling. The first type includes parameters in conceptual models such as the time of concentration for a unit hydrograph. The second type includes parameters in physically-based models subject to scaling issues, such as soil hydraulic conductivity or channel bottom width. Most parameters in the basin model can be classified as one of these two types.

Add a new parameter to an uncertainty analysis using the *Watershed Explorer*. Move the mouse over the analysis and press the right mouse button (Figure 376). A context menu is displayed that contains several choices including adding a parameter. Click the **Add Parameter** command. The parameters are automatically named and numbered beginning with "Parameter 1" and incrementing the number as more parameters are added.

The subbasin canopy parameters that can be added are shown in Table 30. Subbasin surface parameters that can be added are shown in Table 31 and loss rate parameters are shown in Table 32. The available subbasin transform parameters are shown in Table 33 and baseflow parameters are shown in Table 34. Reach routing

parameters that can be added are shown in Table 35 while available reservoir parameters that can be added are shown in Table 36.

Delete a parameter from an uncertainty analysis using the *Watershed Explorer*. Select the parameter you wish to delete by clicking on it in the *Watershed Explorer*; it will become highlighted. Keep the mouse over the selected parameter and click the right mouse button (Figure 377). A context menu is displayed that contains several choices including deleting a parameter. Click the **Delete Parameter** command.

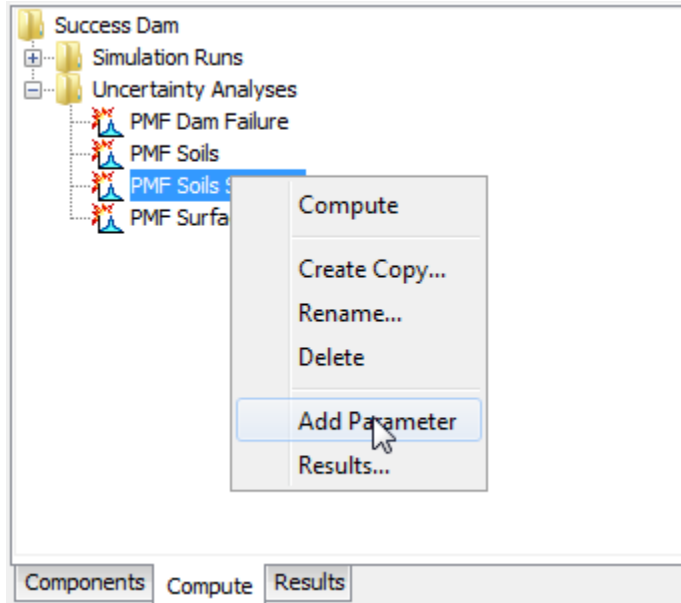

Figure 376. Adding a parameter to an uncertainty analysis.

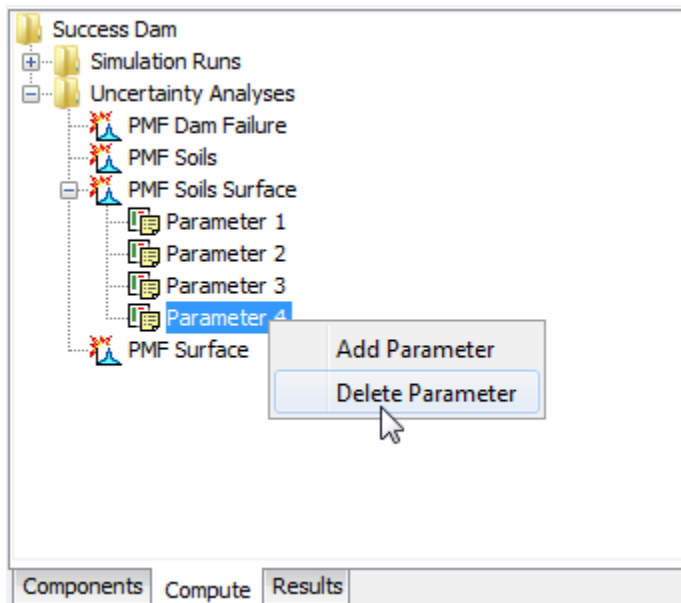

Figure 377. Deleting a selected parameter from an uncertainty analysis.

Table 30. Subbasin canopy parameters available for sampling.

Method	Parameter
Dynamic	Initial Storage
Gridded Simple	Initial Storage
Simple	Initial Storage Maximum Storage

Table 31. Subbasin surface parameters available for sampling.

Method	Parameter
Gridded Simple	Initial Storage
Simple	Initial Storage Maximum Storage

Table 32. Subbasin lossrate parameters available for sampling.

Method	Parameter
Curve Number	Initial Abstraction Constant Rate Impervious Area
Deficit Constant	Initial Deficit Maximum Deficit Constant Rate Impervious Area
Exponential	Initial Range Initial Coefficient Coefficient Ratio Exponent Impervious Area
Green Ampt	Initial Content Saturated Content Suction Conductivity Impervious Area
Gridded Curve Number	Initial Abstraction Ratio Potential Retention Scale Factor

Table 33. continued

<b>Method</b>	<b>Parameter</b>
Gridded Deficit Constant	Initial Deficit Ratio
	Maximum Deficit Ratio
	Constant Rate Ratio
	Impervious Area Ratio
Gridded SMA	Soil Initial Storage
	Groundwater 1 and 2 Initial Storage
Initial Constant	Initial Loss
	Constant Rate
	Impervious Area
Smith Parlange	Initial Content
	Residual Content
	Saturated Content
	Bubbling Pressure
	Pore Distribution
	Conductivity
	Beta Zero
Impervious Area	
Soil Moisture Accounting	Soil Initial Storage
	Soil Storage
	Soil Tension Storage
	Soil Infiltration
	Soil Percolation
	Groundwater 1 and 2 Initial Storage
	Groundwater 1 and 2 Storage
	Groundwater 1 and 2 Percolation
	Groundwater 1 and 2 Coefficient
	Impervious Area

Table 33. Subbasin transform parameters available for sampling.

Method	Parameter
Clark	Time of Concentration Storage Coefficient
Kinematic Wave	Plane Length Plane Slope Plane Roughness Subcollector, Collector, and Main Channel Length Subcollector, Collector, and Main Channel Slope Subcollector, Collector, and Main Channel Manning's n Subcollector, Collector, and Main Channel Bottom Width <sup>1</sup> Subcollector, Collector, and Main Channel Side Slope <sup>2</sup>
ModClark	Time of Concentration Storage Coefficient
SCS	Time Lag
S-Graph	Time Lag
Snyder	Peaking Coefficient Standard Lag

<sup>1</sup> Bottom width can be selected for cross section shapes: deep, rectangle, trapezoid.

<sup>2</sup> Side slope can be selected for cross section shapes: trapezoid, triangle.

Table 34. Subbasin baseflow parameters available for sampling.

Method	Parameter
Bounded Recession	Initial Flow Rate or Initial Flow Rate per Area <sup>1</sup> Recession Constant
Linear	GW 1 and 2 Initial Flow Rate or Initial Flow Rate per Area <sub>1</sub>
Reservoir	Groundwater 1 and 2 Storage Coefficient Groundwater 1 and 2 Number of Steps
Nonlinear Boussinesq	Initial Flow Rate or Initial Flow Rate per Area <sup>1</sup> Characteristic Length Hydraulic Conductivity Drainable Porosity Threshold Ratio or Threshold Flow Rate <sup>2</sup>
Recession	Initial Flow Rate or Initial Flow Rate per Area <sup>1</sup> Recession Constant Threshold Ratio or Threshold Flow Rate <sup>2</sup>

<sup>1</sup> The available parameter depends on the method selected for specifying the initial condition.



<sup>2</sup> The available parameter depends on the method selected for specifying the recession threshold.

*Table 35. Reach routing parameters available for sampling.*

<b>Method</b>	<b>Parameter</b>
Kinematic Wave	Energy Slope Manning's n Diameter <sup>1</sup> Bottom Width <sup>2</sup> Side Slope <sup>3</sup>
Lag	Lag
Modified Puls	Subreaches Initial Flow
Muskingum	K X Subreaches
Muskingum Cunge	Energy Slope Manning's n Diameter <sup>1</sup> Bottom Width <sup>2</sup> Side Slope <sup>3</sup>
Straddle Stager	Lag Duration

<sup>1</sup> Available for the circle cross section.

<sup>2</sup> Available for deep, rectangle, and trapezoid cross section.

<sup>3</sup> Available for trapezoid and triangle cross section.

*Table 36. Reservoir parameters available for sampling.*

<b>Method</b>	<b>Parameter</b>
Initial Condition	Initial Elevation <sup>1</sup> Initial Outflow <sup>1</sup> Initial Storage <sup>1</sup>
Orifice Outlet	Coefficient
Culvert	Entrance Coefficient Exit Coefficient Manning's n
Level Dam Top	Coefficient
Nonlevel Dam Top	Coefficient

Table 37. Continued

Method	Parameter
Broadcrested Spillway	Coefficient
Overtop Breach	Top Elevation Bottom Elevation Bottom Width Left Side Slope Right Side Slope Development Time
Piping Breach	Top Elevation Bottom Elevation Piping Elevation Bottom Width Left Side Slope Right Side Slope Piping Coefficient Development Time

<sup>1</sup> The available parameter depends on the method selected for specifying the initial condition.

### ***Specifying Parameter Information***

Information must be specified for each selected parameter. The first selection is the element (Figure 378). The element selection list includes all of the elements in the basin model where at least one parameter is available for selection. The parameters available for selection will depend on the methods that have been selected. Once the element has been selected, the second selection is the parameter at the chosen element. All of the available parameters at the selected element are included in the list. If the element selection is changed, then a new parameter selection will also need to be made.

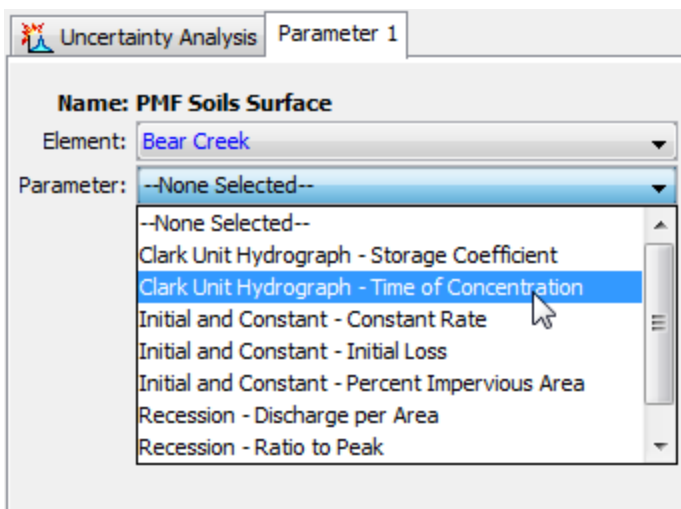

Figure 378. Choosing an element where a parameter will be sampled, and selecting the parameter at that element.

There are three different methods for sampling the selected parameter. The *Component Editor* will display the appropriate property information depending on the sampling method that you choose. The *Simple Distribution* sampling method allows you to choose an analytical probability distribution and then samples the parameter independently of all other parameters selected in the uncertainty analysis. The *Monthly Distribution* sampling method allows you to choose an analytical probability distribution and enter unique distribution properties for each month; the parameter is sampled independently of all other parameters in the analysis. The *Regression With Additive Error* sampling method allows you to choose a previously selected parameter and then define a linear relationship between this dependent parameter and the previously selected parameter; an epsilon error term can be added to the linear relationship. The information specified for each of the three sampling methods is explained in the following sections.

### **Simple Distribution**

The *Simple Distribution* sampling method can be used to define the uncertainty in a parameter independently of all other parameters in the analysis. The sampling process is defined by the selection of a probability distribution function (PDF). There are eight analytical functions available with the choices shown in Table 37. There is also the option of choosing an empirical function. The empirical function must be defined in the paired data manager as a cumulative probability function before it can be selected in the sampling method. A new parameter value is computed for each sample in the analysis according to the PDF selection and the PDF parameter coefficients.

The selection of a PDF determines which additional parameters must be entered. An example of the *Component Editor* is shown in Figure 379. Several of the analytical PDF functions begin at zero, but may need to be applied with parameters that typically begin their range at a value greater than zero. A shift parameter is included with these functions for this purpose.

The screenshot shows a software window titled 'Uncertainty Analysis' with a sub-tab 'Parameter 1'. The main area is a form for configuring a parameter. The 'Name' is 'PMF Soils Surface'. The 'Element' is 'Bear Creek'. The 'Parameter' is 'Clark Unit Hydrograph - Time of Concentration'. The '\*Method' is 'Simple Distribution'. The 'Distribution' is 'Gamma'. The '\*Minimum' is 10, '\*Maximum' is 50, '\*Shift' is 0, '\*Shape' is 8.0, and '\*Scale' is 3.0.

<b>Name: PMF Soils Surface</b>	
Element:	Bear Creek
Parameter:	Clark Unit Hydrograph - Time of Concentration
*Method:	Simple Distribution
Distribution:	Gamma
*Minimum:	10
*Maximum:	50
*Shift:	0
*Shape:	8.0
*Scale:	3.0

Figure 379. Setting sampling properties for a parameter using the Simple Distribution method.

All of the available PDF choices include a minimum and maximum value. These limits are imposed as constraints on the parameter sampling process. If the value computed for a sample falls below the minimum or above the maximum, then a new value is sampled. This process is repeated until a sampled parameter value is generated that falls between the minimum and maximum. These constraints are separate from the mathematical features of the selected PDF. The limits are useful for enforcing physical process limitations or restricting the sampling to a reasonable range for the selected parameter.

### **Monthly Distribution**

The Monthly Distribution sampling method can be used to define the uncertainty in a parameter that shows seasonal variation. The sampling process is defined by the selection of an analytical probability distribution function (PDF) along with separate parameter coefficients of the PDF for each month. The eight available choices for the PDF are shown in Table 37. A new value is computed for each sample in the analysis according to the PDF selection and the PDF parameter coefficients. The simulation start date and time of the uncertainty analysis will be used to determine which monthly parameter coefficients will be used in the sampling process.

Table 37. Analytical probability distribution functions available for parameter sampling and epsilon error term sampling. Parameter labels used in the program are shown below the formula.

Function	Formula
Beta	$f(x) = \frac{1}{B(p, q)} \frac{(x - \min)^{p-1} (\max - x)^{q-1}}{(\max - \min)^{p+q-1}}$ <p>Alpha=<math>p</math>, Beta=<math>q</math>, Lower=<math>\min</math>, Upper=<math>\max</math>  <math>B(p, q)</math> is the Beta function</p>
Exponential	$f(x) = \frac{1}{\beta} \exp\left(-\frac{(x - \min)}{\beta}\right)$ <p>Mu=<math>\beta</math>, Shift=<math>\min</math></p>
Gamma	$f(x) = \frac{(x - \min)^{\alpha-1}}{\beta^\alpha \Gamma(\alpha)} \exp\left(-\frac{x - \min}{\beta}\right)$ <p>Shape=<math>\alpha</math>, Scale=<math>\beta</math>, Shift=<math>\min</math>  <math>\Gamma(\alpha)</math> is the Gamma function</p>
Log-normal	$f(x) = \frac{1}{x \sqrt{2\pi\sigma^2}} \exp\left(-\frac{[\ln(x) - \mu]^2}{2\sigma^2}\right)$ <p>Mu=<math>\mu</math>, Sigma=<math>\sigma</math></p>
Normal	$f(x) = \frac{1}{\sqrt{2\pi\sigma^2}} \exp\left(-\frac{[x - \mu]^2}{2\sigma^2}\right)$ <p>Mu=<math>\mu</math>, Sigma=<math>\sigma</math></p>
Triangular	$f(x) = \begin{cases} \frac{2(x - \min)}{(\max - \min)(\text{mode} - \min)} & \min < x \leq \text{mode} \\ \frac{2(\max - x)}{(\max - \min)(\max - \text{mode})} & \text{mode} < x \leq \max \end{cases}$ <p>Lower=<math>\min</math>, Mode=<math>\text{mode}</math>, Upper=<math>\max</math></p>
Uniform	$f(x) = \frac{1}{\max - \min}$ <p>Lower=<math>\min</math>, Upper=<math>\max</math></p>
Weibull	$f(x) = \frac{\alpha}{\beta} \left(\frac{x - \min}{\beta}\right)^{\alpha-1} \exp\left(-\left[\frac{x - \min}{\beta}\right]^\alpha\right)$ <p>Shape=<math>\alpha</math>, Scale=<math>\beta</math>, Shift=<math>\min</math></p>

The selection of a PDF determines which additional parameters must be entered. An example of the *Component Editor* is shown in Figure 380. A table is used to enter the PDF parameter coefficients for each month. A shift parameter is included with analytical probability distribution functions that begin at zero to account for parameters that for physical reasons should begin at a value greater than zero.

Month	Shift	Shape	Scale
January	0.000	2	12
February	0.000	2	11
March	0.000	2	10
April	0.000		
May	0.000		
June	0.000		
July	0.000		
August	0.000		

Figure 380. Setting sampling properties for a parameter using the Monthly Distribution method.

All of the available PDF choices include minimum and maximum limits that are imposed on the parameter sampling process. The parameter will be repeatedly sampled until a value is obtained that falls between the minimum and maximum. These constraints are separate from the mathematical features of the selected PDF. The limits are useful for enforcing physical process limitations or restricting the sampling to a reasonable range for the selected parameter. The same minimum and maximum is used for all months of the year.

### **Regression With Additive Error**

The Regression With Additive Error sampling method can be used to define the uncertainty in a parameter that has a dependency linkage to another parameter in the analysis. The sampling process is defined by selecting an independent parameter which will become the

basis for generating the sampled value at this parameter. A regression relationship is defined between the two parameters. The calculation process proceeds for a sample by first accessing the value computed for the independent parameter. Then the regression is applied to calculate the preliminary parameter value for this parameter. An epsilon error term is then calculated using one of the eight available analytical PDF choices (Table 37). The sampled epsilon error is added to the preliminary parameter value to produce the value used for a sample.

A regression element (Reg Element) must be selected as shown in the *Component Editor* (Figure 381). The available choices will be taken from the parameters that have been previously defined in the uncertainty analysis. Once a regression element is selected, the regression parameter in the regression element can be selected. The parameter choices will include all of the parameters in the uncertainty analysis at the selected regression element.

The screenshot shows the 'Component Editor' window for 'Parameter 3'. The main title is 'Name: PMF Soils Surface'. Below this, several settings are displayed in a list format:

- Element: Bear Creek
- Parameter: Clark Unit Hydrograph - Storage Coefficient
- \*Method: Regression With Additive Error
- \*Reg Element: Bear Creek
- \*Reg Parameter: Clark Unit Hydrograph - Time of Concentration
- \*Regression: Linear
- \*Slope: 1.5
- \*Intercept: 0.0
- Distribution: Normal
- \*Mu: 0.0
- \*Sigma: 0.75

Figure 381. Setting sampling properties for a parameter using the *Dependent Plus Error* method.

A relationship is used to define the linkage from the selected regression parameter to this parameter. The first possibility for the relationship is a linear one. Alternatively, a semi-logarithmic relationship may be selected. In both cases, you must enter the slope and intercept for the relationship. If the linear relationship is selected, the slope and intercept values should be appropriate for "normal" space. If the log-linear relationship is selected, the slope and intercept values should be appropriate for "natural logarithmic" space.

An epsilon error term is added to the preliminary parameter value calculated from the regression parameter and the linear or semi-logarithmic relationship. The epsilon term represents the error in the fitting relationship between the regression parameter and this parameter. You may choose any one of the eight analytical probability distribution functions to represent the error term. Based on the selected PDF, parameter coefficients must be entered to define the distribution.

## **Computing Results for an Analysis**

Results for an uncertainty analysis are generated by computing it. Changes in all the components used in the analysis are automatically tracked to determine if the results are current. When the results are no longer current, the analysis must be recomputed in order to refresh the results. Computing results begins with selecting an uncertainty analysis.

### **Choosing Output Results**

The uncertainty analysis is the only computation method that requires choosing output results. Results are automatically stored for all elements in the simulation run, optimization trial, forecast alternative, and depth-area analysis. These other computation methods can store results for all elements because the amount of computed output is relatively compact. Conversely, if results were stored for all elements in the uncertainty analysis, the amount of computed output would be significant and potentially overwhelming. Choosing the elements in the uncertainty analysis where output results will be stored saves space and improves manageability.

Choose the output results for an uncertainty analysis using the *Watershed Explorer*. Move the mouse over the analysis and press the right mouse button (Figure 382). A context menu is displayed that contains several choices including results. Click the **Results...** command to choose the output results for the uncertainty analysis. The *Results* window (Figure 383) will open for choosing the output results.



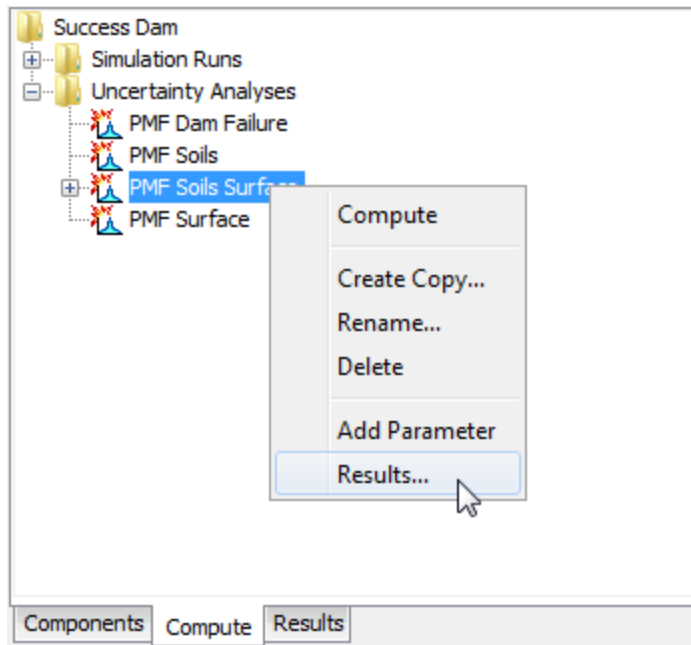

Figure 382. Preparing to choose the element and time-series output results for an uncertainty analysis.

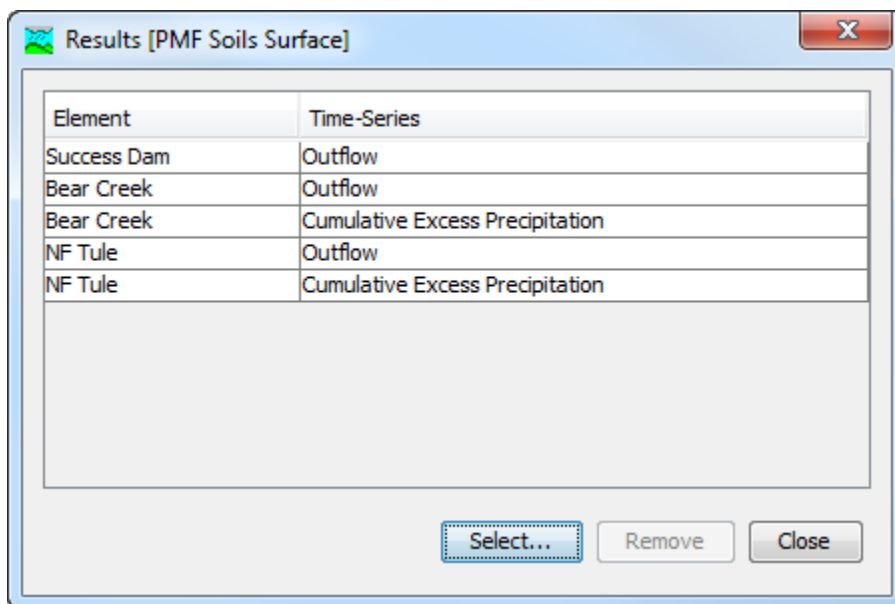

Figure 383. Choosing the elements and time-series for output results.

The *Results* window displays the elements and time-series that will be stored when the uncertainty analysis is computed. Press the **Select...** button to choose additional time-series. The *Select Results* window (Figure 384) is used to choose time-series at specific elements. All of the elements in the uncertainty analysis are shown on the left side of the window. Click on an element to choose a result from among the time-series computed at the element. Only one element can be selected at a time. After clicking on an element, the available time-

series at the element will be shown on the right side of the window. Select the time-series that should be added to the stored results. Multiple time-series can be selected simultaneously by holding the control key and clicking on additional time-series. Press the **Select** button and the selected time-series for the selected element will be added to the stored results. Additional elements and time-series can be selected. Press the **Close** button when you have finished choosing results.

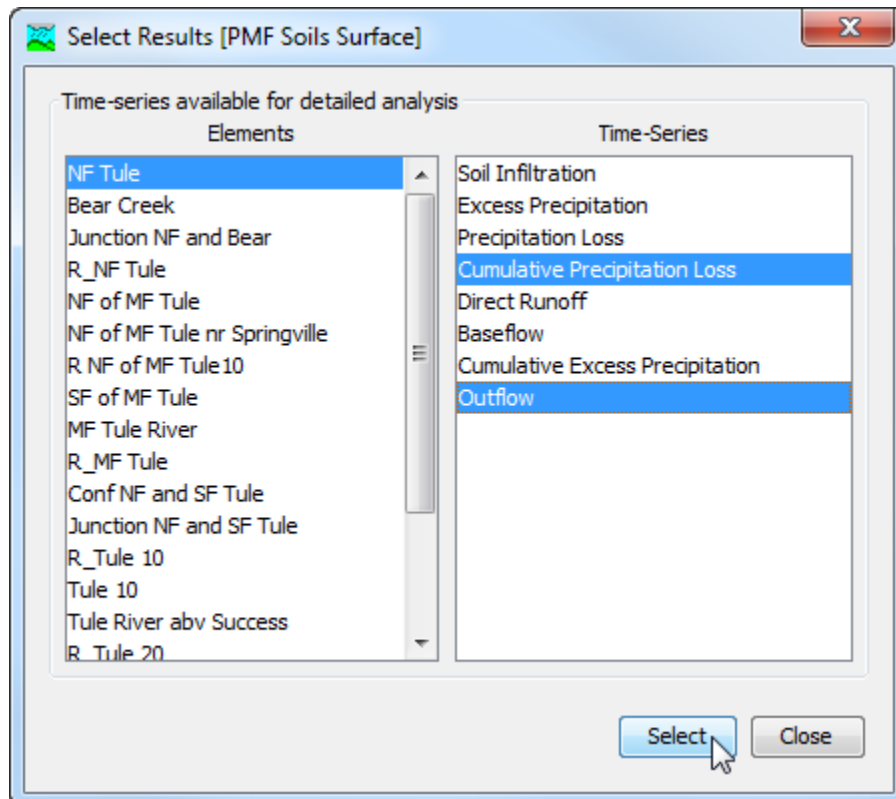

Figure 384. Choosing two time-series at an element for the output results.

The *Results* window is also used to stop storing elements and time-series data when the uncertainty analysis is computed. Time-series that have been removed will not be stored the next time the uncertainty analysis is computed. Select the row in the table that should be removed from the stored results. Multiple rows can be selected simultaneously by holding the control key and clicking on additional rows (Figure 385). Press the **Remove** button and the selected elements and time-series will no longer be stored. Press the **Close** button when you have finished removing elements and time-series.

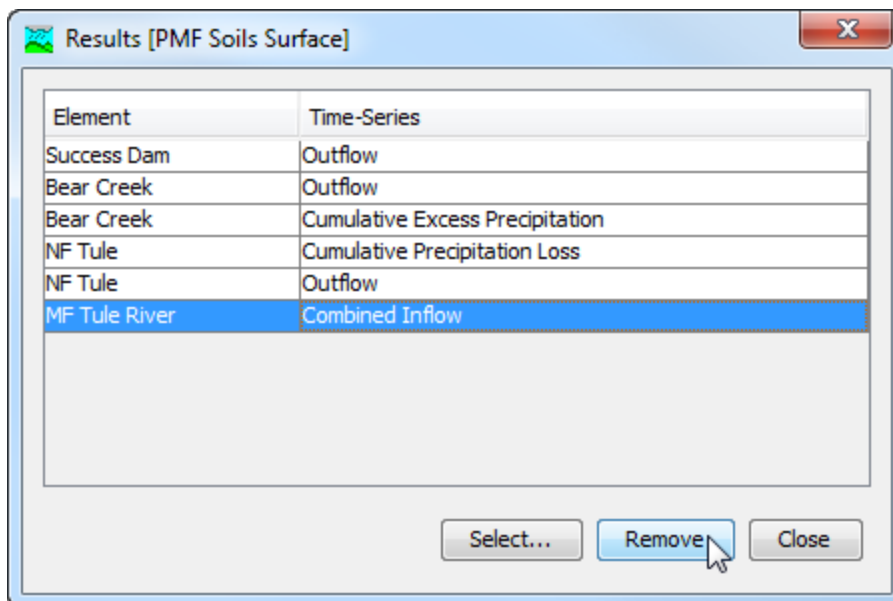

Figure 385. Removing a selected time-series from the output results.

### Selecting a Current Uncertainty Analysis

There are two ways to select the current uncertainty analysis. Both methods set the analysis so that it can be computed and results can be accessed from the *Watershed Explorer* as soon as they are available. The current uncertainty analysis is shown in the title of the basin map even though results cannot currently be selected through the map.

The first way to select the current uncertainty analysis is from the toolbar. The compute selection box shows all of the compute components in the project; uncertainty analyses appear after depth-area analyses in the selection box. Each uncertainty analysis in the selection box includes the prefix `Uncertainty` followed by the name of the analysis. Click on the toolbar selection box and choose an uncertainty analysis to become the current analysis.

The second way to select the current uncertainty analysis is from the *Watershed Explorer*, on the "Compute" tab. Select the uncertainty analysis you wish to become the current analysis by clicking on it in the *Watershed Explorer*. The uncertainty analyses are listed alphabetically in the "Uncertainty Analyses" folder.

### Computing an Uncertainty Analysis

There are three ways to compute the currently selected uncertainty analysis. All methods automatically perform parameter checking, and if no errors are generated, proceed to the actual computing of uncertainty analysis results. Additionally, the program is designed to be computationally efficient. Only components with data changes

since the last compute will be recomputed; the remainder of the components have not changed so previous alternative results are still applicable. If you wish, you may force all components to be recomputed regardless of data changes since the last compute.

The first way to compute an uncertainty analysis is from the **Compute** menu. Click on the **Compute** menu and then select the **Compute Uncertainty** command. The name of the current uncertainty analysis is shown in brackets as part of the menu command. If the command is not available, it is because there is no current uncertainty analysis; you must first select an analysis. A window will automatically open that shows the progress of the compute. You will need to manually close the window when the compute is done, whether it failed or was successful. If you wish to force all components to be recomputed instead of just those with data changes, hold the *control* key while selecting the menu command.

The second way to compute an uncertainty analysis is from the *Watershed Explorer*, on the "Compute" tab. Select the uncertainty analysis you wish to compute by clicking on it in the *Watershed Explorer* with the right mouse button. A context menu is displayed that contains several choices including compute. Click the **Compute** command. The progress window will automatically open. If you wish to force all components to be recomputed instead of just those with data changes, hold the *control* key while selecting the right mouse menu command.

The third way to compute an uncertainty analysis is from the toolbar. The compute button is enabled whenever there is a current analysis that can be computed. If the button is not available or shows a different type of compute, you must first select an uncertainty analysis. Press the button to compute the current uncertainty analysis. The progress window will automatically open. If you wish to force all components to be recomputed instead of just those with data changes, hold the *control* key while selecting the toolbar button.

### **Computing Multiple Analyses**

Multiple uncertainty analyses can be computed in rapid succession. This feature should be used carefully because the time required to compute an uncertainty analysis is much longer than all other compute types. Each simulated analysis is internally managed the same as if it were computed in isolation. The steps performed for the user begin with selecting the uncertainty analysis, checking parameters for the analysis, and finally computing the simulation. This sequence is repeated in rapid succession for each uncertainty analysis in the selected set. Appropriate feedback is provided through a progress bar.

The multiple uncertainty analyses must exist before they can be selected for a multiple compute. Select the **Multiple Compute** command on the **Compute** menu. A manager is used to select uncertainty analyses (Figure 386). Make selections in the list and then press the **Compute** button to begin computing the selected analyses. A separate progress bar will be displayed for each uncertainty analysis as it is computed. The progress bar may disappear automatically at the conclusion of an uncertainty analysis depending on the configurations in the *Program Settings*. If errors are encountered while computing an analysis, the progress bar will always remain visible after all selected analyses have finished computing regardless of any other settings.

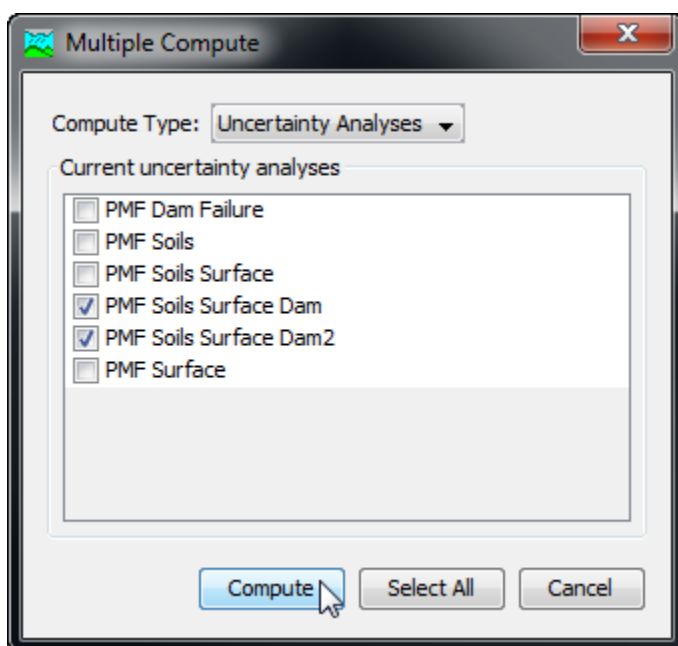

Figure 386. Selecting multiple uncertainty analyses for sequential compute.

## Viewing Results for an Analysis

A variety of graphical and tabular results are available after an uncertainty analysis is computed. The program tracks all of the data in the uncertainty analysis, the selected basin model, and the selected meteorologic model. It also tracks any time-series data, paired data, or grid data used in the basin and meteorologic models. Results for an uncertainty analysis can only be accessed when none of this data has changed since the last time the analysis was computed. If any of the data has changed, you will need to recompute the uncertainty analysis before you will be allowed to start accessing results.

Once a result is open for viewing it will remain open until it is closed by the user. It is possible that data used during the simulation that

produced the result could change while the result is open for viewing. In this case, the open result will immediately show an indication that data has changed and the uncertainty analysis needs to be recomputed. After the analysis is recomputed the open results are automatically updated with the new results and the indication is updated with the date and time of the most-recent compute.

### ***Sampled Parameters***

The uncertainty analysis includes a number of parameters that are sampled during the simulation. A new parameter value is sampled for each sample of the simulation. The sequence of sampled values from the first sample to the last sample is stored separately for each parameter and may be viewed in a table. Each parameter sample can be accessed by clicking the "Parameter" node on the "Results" tab of the *Watershed Explorer* (Figure 387). The parameter sample table will open. The table includes one row for each sample of the simulation. The first column of the table displays the sample number while the second column displays the sampled parameter value. An example of a parameter sample is shown in Figure 388.

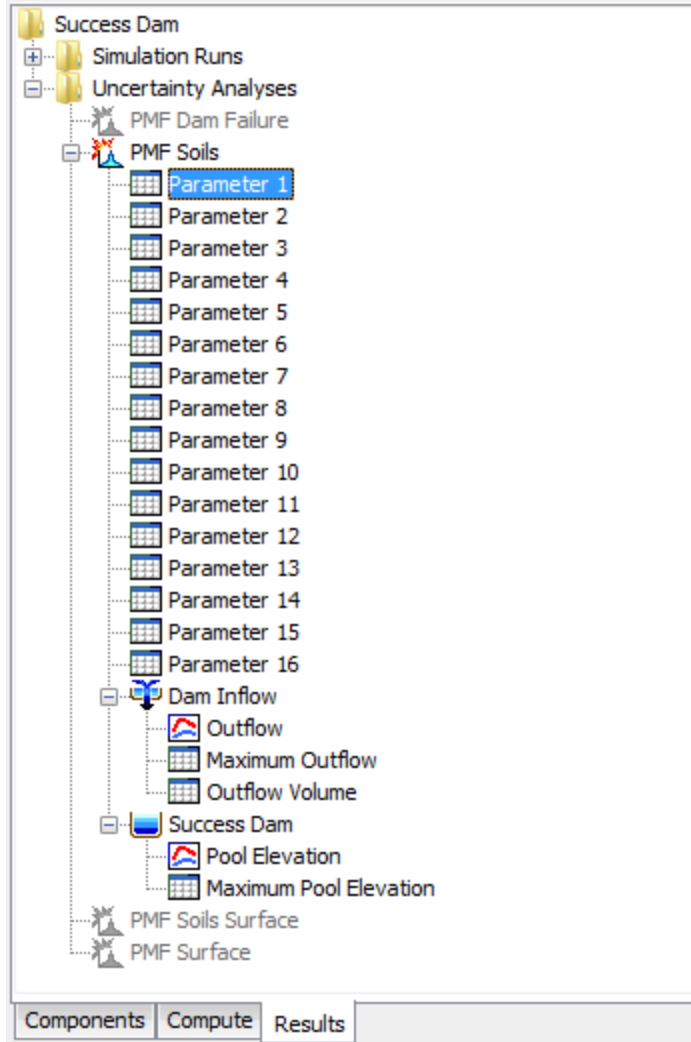

Figure 387. Watershed Explorer showing parameter sample results for an uncertainty analysis.

Project:Success Dam    Uncertainty Analysis:PMF Soils  
 Element: Bear Creek    Parameter: Initial and Constant - Initial Loss

Start of Analysis: 04Dec1966, 01:00    Basin Model:    Calibrated Model  
 End of Analysis: 08Dec1966, 00:00    Meteorologic Model: 1966 event  
 Compute Time: 29Jul2015, 17:08:04

Sample Number	Parameter Value
1	1.5330
2	0.21005
3	1.0516
4	1.6301
5	0.44212
6	0.25532
7	1.1488
8	0.56201
9	0.89891
10	0.25193
11	0.0689404
12	1.2463
13	0.87998
14	0.95199
15	1.5167
16	1.6576
17	0.87078
18	0.88699
19	0.20476
20	0.63624
21	0.37555
22	1.0113
23	0.22839
24	0.90572

Figure 388. A parameter sample showing the sampled parameter value for each sample of the uncertainty analysis simulation.

### Individual Elements

The uncertainty analysis may include one or more locations where output results have been selected. Special tabular and graphical results may be viewed when outflow or pool elevation is selected. The element outflow is available at all seven element types including subbasin, reach, junction, source, diversion, reservoir, and sink. The pool elevation is only available at reservoir elements where the storage is specified with an elevation-storage or elevation-area curve. Other computed time-series may be selected and will be stored in the uncertainty analysis output HEC-DSS file. These other computed time-series may be viewed and analyzed using the HEC-DSSVue software.



Two different tables are available when outflow is selected for a location. The first table displays the maximum outflow for each sample of the uncertainty analysis. The second table displays the outflow volume for each sample. The tables can be accessed by expanding the element node on the "Results" tab of the *Watershed Explorer* (Figure 389) and clicking on the result node. The selected table will open. Each table includes one row for each sample of the simulation. The first column of the table displays the sample number while the second column displays either the maximum outflow or the outflow volume. An example of the outflow volume table is shown in Figure 390.

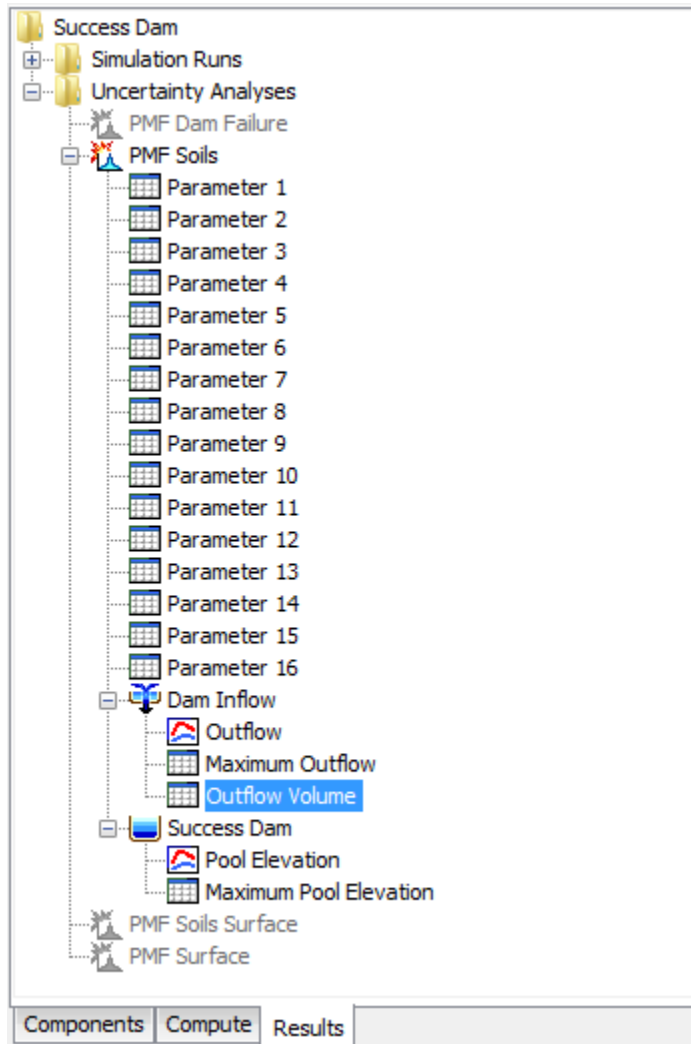

Figure 389. *Watershed Explorer* showing outflow results for a selected location in an uncertainty analysis.

Project:Success Dam    Uncertainty Analysis:PMF Soils  
 Element:Success Dam    Statistic:Outflow Volume

Start of Analysis:04Dec1966, 01:00    Basin Model:    Calibrated Model  
 End of Analysis: 08Dec1966, 00:00    Meteorologic Model:1966 event  
 Compute Time: 29Jul2015, 17:08:04

Sample Number	Statistic Value
1	4199.8
2	8219.2
3	11565
4	12605
5	12827
6	10535
7	9409.6
8	11598
9	9768.5
10	12074
11	3463.7
12	6062.0
13	6311.4
14	9641.1
15	4283.6
16	11554
17	10512
18	3287.5
19	7632.1
20	10933
21	4229.5
22	12813
23	9541.4

Figure 390. A statistic output showing the outflow volume for each sample of the uncertainty analysis simulation.

An outflow graph is also available when outflow is selected for a location. The graph represents a statistical analysis of the outflow time-series computed for each sample of the simulation. The minimum and maximum value across all samples is determined for each interval of the simulation time window. Additionally, the mean and standard deviation are computed for each time interval. The graph presents the data as the mean, mean plus the standard deviation, mean minus the standard deviation, maximum, and minimum. An example graph is shown in Figure 391. The graph can be accessed by clicking on the node under the selected element location.

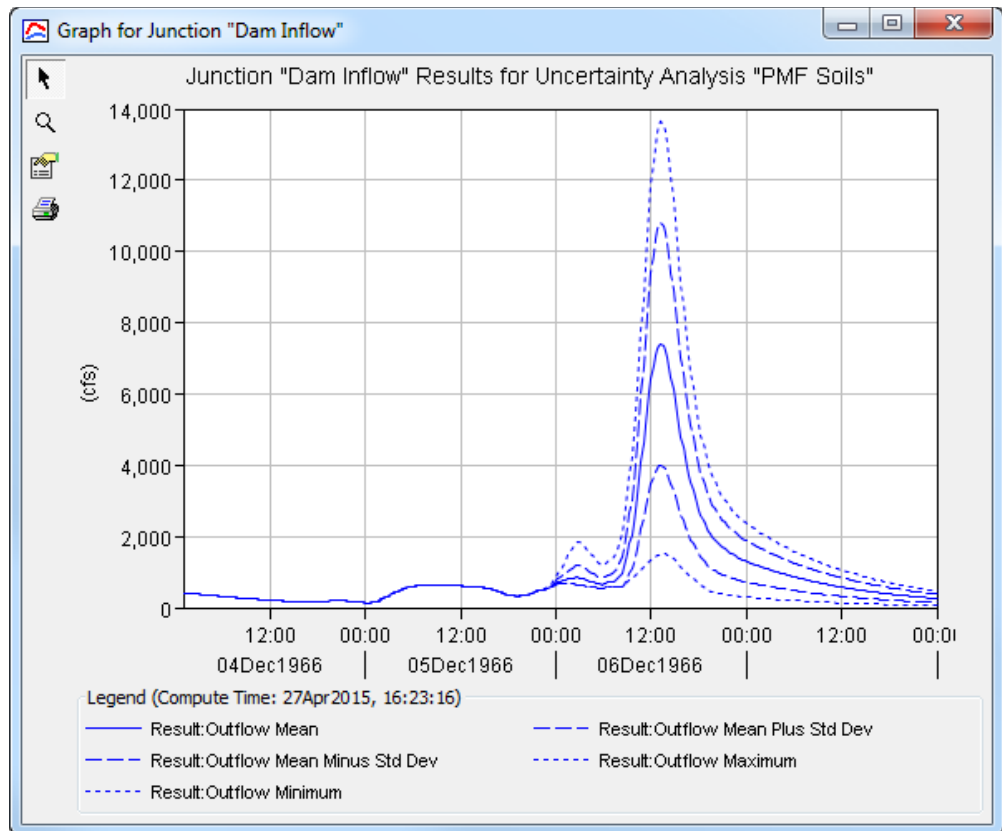

Figure 391. Outflow result graph for an uncertainty analysis showing the mean and other statistical measures for each time interval.

A table and a graph are available when pool elevation is selected for a reservoir location. The table displays the maximum pool elevation for each sample of the uncertainty analysis. The first column of the table displays the sample number while the second column shows the maximum pool elevation. The table can be accessed by expanding the reservoir node in the *Watershed Explorer* and clicking on the result node in the same way described above for accessing outflow results. An example of a maximum pool elevation table is shown in Figure 392.

Project:Success Dam      Uncertainty Analysis:PMF Surface  
Element:Success Dam      Statistic:Maximum Pool Elevation

Start of Analysis:01Feb2100, 00:00      Basin Model:      PMF Simulation  
End of Analysis: 10Feb2100, 00:00      Meteorologic Model:PMP\_TimePattern1Spatial66  
Compute Time: 29Jul2015, 17:21:42

Sample Number	Statistic Value
1	690.29
2	688.10
3	688.21
4	687.64
5	687.48
6	688.65
7	690.11
8	689.92
9	686.69
10	687.38
11	686.39
12	688.20
13	689.55
14	689.99
15	687.86
16	688.84
17	689.04
18	686.37
19	687.25
20	688.83
21	687.54
22	686.67
23	688.56
24	686.84

Figure 392. A statistic output showing the maximum pool elevation in a reservoir for each sample of the uncertainty analysis simulation.

The pool elevation graph represents a statistical analysis of the pool elevation time-series computed for each sample of the simulation. The analysis is presented as the mean pool elevation, mean plus the standard deviation, mean minus the standard deviation, maximum, and minimum for each time interval of the simulation. The graph can be accessed by clicking on the node under the selected reservoir location. An example of a pool elevation graph is shown in Figure 393.

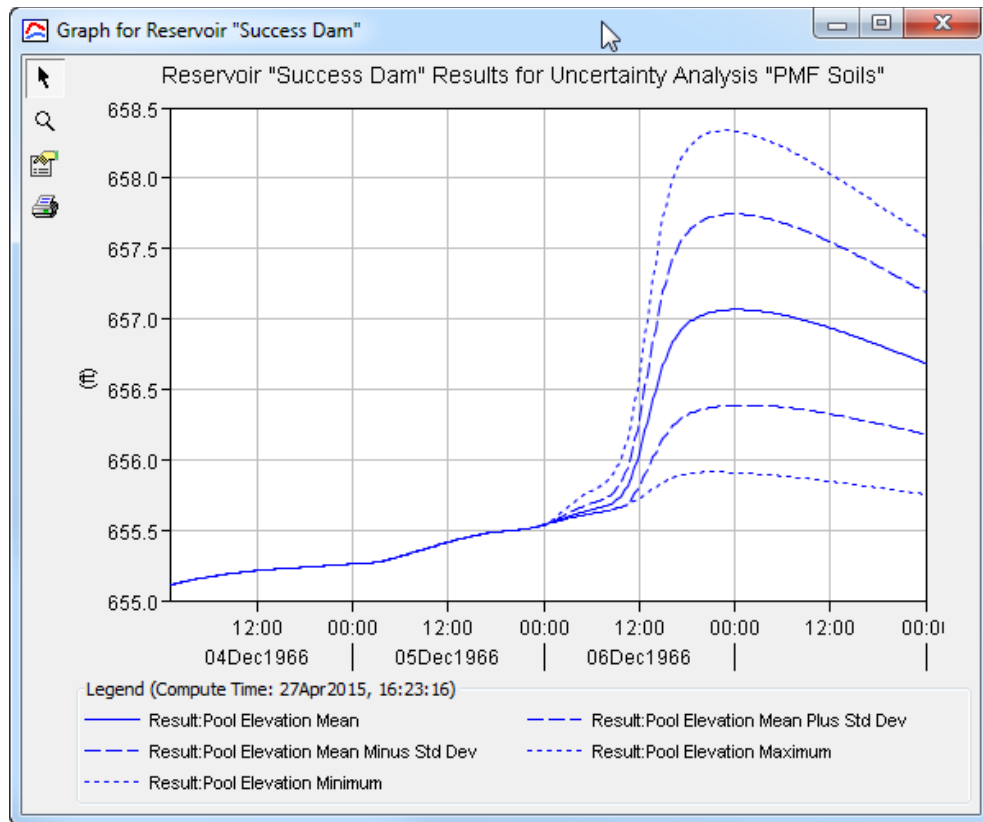

Figure 393. Pool elevation result graph for an uncertainty analysis showing the mean and other statistical measures for each time interval.

This Page Left Blank

## CHAPTER 17

# ***Erosion and Sediment Transport***

When water flows over the land surface and through stream channels, it affects the landscape in significant ways. Shallow surface flow erodes soil and carries the material overland to headwater streams. Steep headwater streams have high flow velocity that leads to stream bed erosion. Eroded surface soil and bed material can be carried by the stream flow to lower reaches of the watershed. Sediment is often deposited in the lower reaches where the flow velocity slows. Reservoirs in the watershed will trap some or most of the sediment that enters with the inflow. Diversion structures can also affect the movements of sediment through the watershed. Erosion and sediment transport lead to a number of problems best evaluated in conjunction with hydrologic simulation.

### ***Watershed Sediment Properties***

Erosion and sediment transport are optional components in the basin model. By default, the component features are deactivated, data entry tools for sediment are not visible in the program interface, and no sediment results are computed during a simulation. The features become accessible when they are activated for the basin model. Activate the features on the *Component Editor* for the basin model (Figure 394). Access the *Component Editor* by clicking the basin model icon on the "Components" tab of the *Watershed Explorer*. Use the selection list to switch between activating and deactivating the sediment features. When the features are turned on, you must make selections and enter parameter data at each element (subbasin, reach, reservoir, source, and diversion) in the basin model. When the features are deactivated, all parameter data for the sediment methods are deleted from the basin model and its elements. Once the sediment components have been deactivated, it is not possible to recover the deleted settings or parameter values.

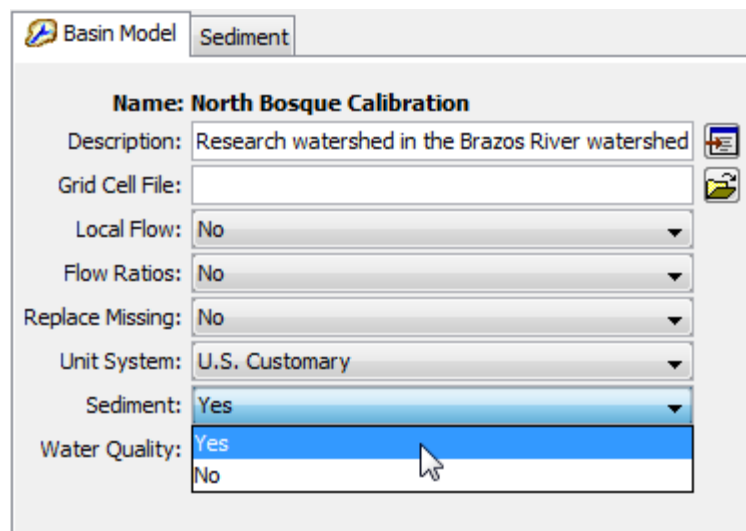

Figure 394. Activating the erosion and sediment transport features in the basin model.

Erosion and sediment transport modeling requires a number of properties to be specified. These global properties are applied to all elements in the basin model. The properties are presented on a separate *Component Editor* from the basin model editor. The "Sediment" editor is always shown next to the "Basin Model" editor (Figure 395).

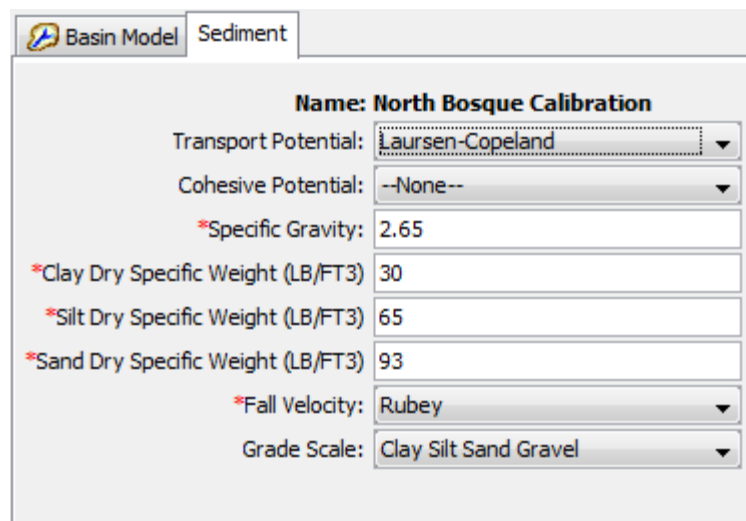

Figure 395. Selecting important sediment methods and entering parameter data that will be applied to all elements within the basin model.

The transport potential method specifies how the sediment carrying capacity of the stream flow will be calculated for non-cohesive sediments. Many methods have been proposed for calculating the transport potential. Each method is developed for a particular sediment grain-size distribution and environmental conditions. The



same transport potential method will be used at all reaches within the basin model. The available choices are shown in Table 38. A cohesive transport potential method can also be selected. When selected, transport of cohesive sediment is computed in addition to the non-cohesive sediment.

*Table 38. Transport potential functions for calculating the amount of sediment that can be carried by the stream flow. Type is non-cohesive (NC) or cohesive (CO). Method is excess shear (ES), stream power (SP), or regression (RE).*

Method	Type	Method	Reference
Ackers-White	NC	SP	Ackers and White, 1973
Engelund-Hansen	NC	SP	Engelund and Hansen, 1967
Laursen-Copeland	NC	ES	Laursen, 1958; Copeland and Thomas, 1989
Meyer-Peter Muller	NC	ES	Meyer-Peter and Müller, 1948
Toffaleti	NC	RE	Toffaleti, 1968
Wilcock	NC	ES	Wilcock and Crowe, 2003
Yang	NC	SP	Yang, 1984
Krone Parthenaides	CO	–	Krone, 1962; Parthenaides, 1962

The specific gravity of the sediment grains must be specified. The default value of 2.65 is provided. The default value may be changed if a different value is more appropriate in your watershed.

The density of dry clay sediment must be specified as appropriate for the selected unit system. The default dry density is 481 kg/m<sup>3</sup> while the default dry specific weight is 30 lb/ft<sup>3</sup>. The same density is used for all size subclasses of clay.

The density of dry silt sediment must be specified with the same density used for all size subclasses. The default dry density is 1,041 kg/m<sup>3</sup> while the default dry specific weight is 65 lb/ft<sup>3</sup>.

The density of dry sand, gravel, cobble, and boulder sediments must be specified. The same density is used for all size subclasses from very fine sand to boulders. The default dry density is 1,490 kg/m<sup>3</sup> while the default dry specific weight is 93 lb/ft<sup>3</sup>.

Some of the available transport potential methods require the calculation of fall velocity. Fall velocity is also used in several of the sediment settling methods for the reservoir element. All reaches and

reservoirs that require the calculation of a fall velocity will use the method selected in the sediment properties. The available methods for calculating fall velocity include Report 12 (Interagency Committee, 1957), Rubey (1933), Toffaletti (1968), and Van Rijn (1993). The default selection is Rubey.

Two different grade scale systems are available. The selected system will determine the number of grain sizes used for calculating erosion and sediment transport throughout the basin model. Calculations of erosion, deposition, settling, and transport are carried out separately and independently for each size in the selected grade scale. The Clay Silt Sand Gravel system only recognizes four broad size classifications. The AGU 20 system recognizes 20 different size classifications, generally breaking each of the four broad size classifications into sub-classifications.

## **Subbasin**

A subbasin element represents a catchment where precipitation falls and causes surface runoff. Erosion within the catchment will result from a combination of several different physical processes. Rain drops cause erosion when they impact the ground surface and break apart the top layer of the soil, dislodging soil particles to move with the overland flow. Overland flow also imparts an erosive energy to the ground surface that may further break apart the top soil layer. As the overland flow rate increases, the flow becomes concentrated in rills which focuses erosive energy and further erodes the surface. Total erosion is closely linked to precipitation rate, land surface slope, and condition of the surface. In some cases, soil eroded high in the catchment may deposit before reaching the outlet of the subbasin.

Certain simulation features are common to all of the surface erosion methods available for the subbasin element. Each erosion method computes the total sediment load transported out of the subbasin during a storm. This calculation process is repeated for each storm during the simulation time window. The sediment load must be distributed into a time-series of sediment discharge from the subbasin. The distribution of sediment is based on the computed hydrograph and the power function approach of Haan *et al.* (1994). The power function is given by

$$c_t = k^i Q_t^a$$

where  $c_t$  is the sediment concentration at time  $t$ ,  $k^i$  is the proportion of the load for the current event  $i$  to the total annual load,  $Q_t$  is the subbasin discharge (flowrate) at time  $t$ , and  $a$  is an exponent entered by the user.

Also common to all of the surface erosion methods is the approach to grain size distribution. All of the methods first compute the bulk sediment discharge which includes all grain sizes. A gradation curve specifies the proportion of the total sediment discharge that should be apportioned to each grain size class or subclass. A gradation curve must be defined by the user and selected at each subbasin. A different gradation curve can be used at each subbasin to represent differences in the erosion, deposition, and resuspension processes within each subbasin. The combination of these processes is often represented by an enrichment ratio.

### Selecting an Erosion Method

The erosion method for a subbasin is selected on the *Component Editor* for the subbasin element (Figure 396). Access the *Component Editor* by clicking the subbasin element icon on the "Components" tab of the *Watershed Explorer*. You can also access the *Component Editor* by clicking on the element icon in the basin map, if the map is currently open. You can select an erosion method from the list of three available choices. If you choose the `None` method, the subbasin will not compute any erosion and all sediment discharges from the element will be zero. Use the selection list to choose the method you wish to use. Each subbasin may use a different method or several subbasins may use the same method.

Loss	Transform	Baseflow	Erosion	Options
Subbasin		Canopy		Surface
<b>Basin Name: North Bosque Calibration</b>				
<b>Element Name: SFork Mid Basin</b>				
Description:				
Downstream: J15				
*Area (MI2) 4.4822				
Latitude Degrees:				
Longitude Degrees:				
Canopy Method: Simple Canopy				
Surface Method: Simple Surface				
Loss Method: Soil Moisture Accounting				
Transform Method: Clark Unit Hydrograph				
Baseflow Method: Linear Reservoir				
Erosion Method: Modified USLE				
--None-- Build-up Wash-off Modified USLE				

Figure 396. Selecting the surface erosion method for a subbasin element.

The parameters for each erosion method are presented on a separate *Component Editor* from the subbasin element editor. The "Erosion" editor is always shown next to the "Baseflow" editor. The information shown on the erosion editor will depend on which method is currently selected.

### **Build-up Wash-off**

The build-up wash-off erosion method is designed for urban environments. In these environments, sediment accumulates in street curbs due to wind deposit and erosion from pervious areas adjacent to the curbs. The sediment accumulates during dry periods between storms. During a storm, the accumulated sediment is flushed from the street curbs by stormwater runoff. The method may optionally include street sweeping operations designed to mechanically remove accumulated sediment. A typical example of source data for parameterizing the method is Breault *et al.* (2005) though data sources should always be recognized as highly local. The *Component Editor* is shown in Figure 397.

Parameter	Value
*Initial Time (DAYS)	0
*Half Time (DAYS)	6
*Max Solids (KG/KM)	0.031
*Density (M/HA)	180
*Sweeping (%)	90
*Efficiency (%)	45
*Interval (DAYS)	7
*Coefficient (1/MM)	0.24
*Exponent	0.75
Gradation Curve	Field Sample 2B

Figure 397. Build-up wash-off erosion method editor at a subbasin element.

The initial time is an initial condition for the method. It specifies the number of days since the last sweeping operation when the simulation begins.

The half time specifies the number of days required for half of the maximum solids to accumulate in the street curb under continuously dry conditions.

The maximum solids amount is the limit to the accumulated sediment in the street curb under continuously dry conditions. Sediment will not exceed this amount even if there is no precipitation for an extended period of time.

This erosion method includes four parameters to describe the street sweeping operations within the subbasin. The density specifies the total length of street curb whether or not the curb is subject to sweeping operations. The density should consider whether the street has curbs on one side or both sides of the street. The sweeping percentage specifies the percentage of the curb length subject to sweeping. The percentage should account for the possible presence of parked cars which result in missed curb. The efficiency percentage specifies the efficiency of the sweeping equipment at removing accumulated sediment. Finally, the interval specifies the number of days between scheduled sweeping operations.

The wash-off coefficient determines how quickly the accumulated sediment is removed from the street curb during a storm event.

The exponent is used to distribute the sediment load into a time-series sedigraph. A small value flattens the sedigraph compared to the hydrograph. A large value heightens the sedigraph compared to the hydrograph.

The gradation curve defines the distribution of the total sediment load into grain size classes and subclasses. The gradation curve is defined as a diameter-percentage function in the *Paired Data Manager*. The current functions are shown in the selection list. If there are many different functions available, you may wish to choose a function from the selector accessed with the paired data button next to the selection list. The selector displays the description for each function, making it easier to select the correct one.

### ***Modified USLE***

The modified USLE method (Williams, 1975) was adapted from the original Universal Soil Loss Equation. The original equation was based on precipitation intensity, and consequently could not differentiate between storms with low or high infiltration. With high infiltration, there is little surface runoff and little accompanying surface erosion. Conversely, low infiltration events have relatively more surface runoff and consequently more surface erosion. The modifications to the original USLE equation changed the formulation to calculate erosion from surface runoff instead of precipitation. The other components of the original formulation remained the same. The method works best in agricultural environments where it was developed. However, some

users have adapted it to construction and urban environments. The *Component Editor* is shown in Figure 398.

Figure 398. Modified USLE erosion method editor at a subbasin element.

The erodibility factor describes the difficulty of eroding the soil. The factor is a function of the soil texture, structure, organic matter content, and permeability. Typical values range from 0.05 for unconsolidated loamy sand to 0.75 for silty and clayey loam soils.

The topographic factor describes the susceptibility to erosion due to length and slope. It is based on the observation that long slopes have more erosion than short slopes, and steep slopes have more erosion than flat slopes. Typical values range from 0.1 for short and flat slopes to 10 for long or steep slopes.

The cover factor describes the influence of plant cover on surface erosion. Bare ground is the most susceptible to erosion while a thick vegetation cover significantly reduces erosion. Typical values range from 1.0 for bare ground, to 0.1 for fully mulched or covered soils, to as small as 0.0001 for forest soils with a well developed soil O horizon under a dense tree canopy.

The practice factor describes the effect of specific soil conservation practices, sometimes called best management practices. Agricultural practices could include strip cropping, terracing, or contouring. Construction and urban practices could include silt fences, hydro seeding, and settling basins. It is difficult to establish general ranges for these practices as they are usually highly specific.

Only some precipitation events will cause surface erosion. The threshold can be used to set the lower limit for runoff events that cause

erosion. Events with a peak flow less than the threshold will have no erosion or sediment yield.

The exponent is used to distribute the sediment load into a time-series sedigraph. A small value flattens the sedigraph compared to the hydrograph. A large value heightens the sedigraph compared to the hydrograph.

The gradation curve defines the distribution of the total sediment load into grain size classes and subclasses. The gradation curve is defined as a diameter-percentage function in the *Paired Data Manager*. The current functions are shown in the selection list. If there are many different functions available, you may wish to choose a function from the selector accessed with the paired data button next to the selection list. The selector displays the description for each function, making it easier to select the correct one.

## **Reach**

Sediment processes within a reach are directly linked to the capacity of the stream flow to carry eroded soil. The transport capacity of the flow can be calculated from the flow parameters and sediment properties. If the stream can transport more sediment than is contained in the inflow, additional sediment will be eroded from the stream bed and entrained in the flow. However, if the flow in the reach cannot transport the sediment of the inflow, entrained sediment will settle and be deposited to the reach bed. The sediment transport capacity is calculated using the transport potential method.

The deposition of sediment from the water column to the stream bed requires time. The fall velocity of reach grain size class provides a physical basis for determining how much time is required for sediment in excess of the transport capacity to settle from the water column to the stream bed. The settling velocity is calculated and multiplied by the time interval to determine the settling distance in one time interval. This settling distance is then compared to the flow depth calculated during flow routing in order to determine the fraction of calculated deposition which is actually permitted during a time interval. The approach here is similar to the one used in HEC-RAS.

The erosion of sediment from the stream bed and entraining into the stream flow requires time. Erosion limitation has been observed but the theoretical basis is less clear than for deposition limitation. An empirical rule is used wherein a characteristic flow length necessary for erosion is calculated. Erosion is limited when the length of the reach divided by the flow depth is less than 30. This empirical rule is similar to one used in HEC-RAS.

The reach bed is represented with a two-layer model. The upper layer represents the top of the stream bed which actively interacts with the flow field. This layer responds relatively quickly to changes in flow rate. The lower layer is linked to the upper layer with a simple bed mixing algorithm. The lower layer represents the underlying substrate of the reach. Long-term processes that lead to a reach being either a sediment sink or sediment source within the watershed are represented through the lower layer. The two-layer model is also capable of representing an "armouring" condition, which reduces the rate of erosion as the upper layer coarsens.

As a simplifying assumption, the cross section shape of the channel is fixed. There is no feedback between sediment dynamics and flow routing. A characteristic width and depth of the sediment bed within the reach is used to represent the two-layer model.

### Selecting a Sediment Method

The sediment method for a reach is selected on the *Component Editor* for the reach element (Figure 399). Access the *Component Editor* by clicking the reach element icon on the "Components" tab of the *Watershed Explorer*. You can also access the *Component Editor* by clicking on the element icon in the basin map, if the map is currently open. You can select a sediment method from the list of five available choices. If you choose the `None` method, the reach will not compute any sediment and all sediment discharges from the element will be zero. Use the selection list to choose the method you wish to use. Each reach may use a different method or several reaches may use the same method.

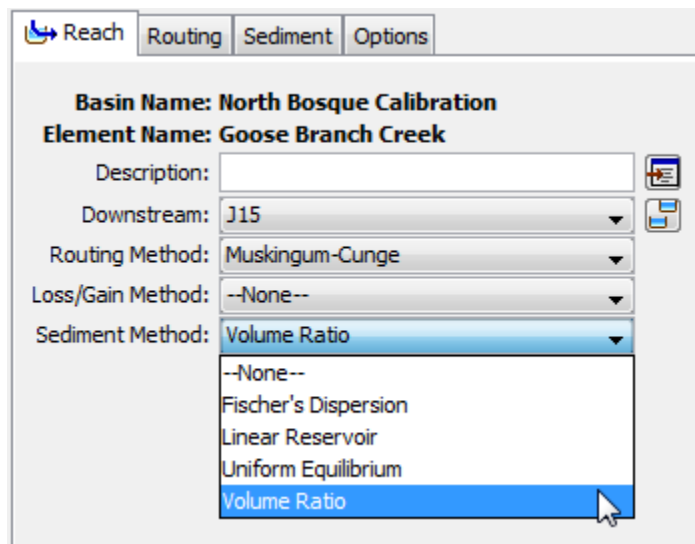

Figure 399. Selecting a channel sediment transport method for a reach element.



The parameters for each sediment method are presented on a separate *Component Editor* from the reach element editor. The "Sediment" editor is always shown next to the "Routing" editor. The information shown on the sediment editor will depend on which method is currently selected.

### ***Fisher's Dispersion***

The Fisher's dispersion method is based on an analysis of the advection and diffusion of sediment within a reach (Fisher *et al.*, 1979). This is the most detailed of the sediment routing methods and requires more data than some of the other available methods. Separate specification of the advection and diffusion parameters for each grain size class permits the large-grained sediments to move slower than the fine-grained sediments. For each time interval, sediment from upstream elements is added to the sediment already in the reach. After erosion or deposition is calculated, the remaining available sediment is translated in the reach by a travel time and attenuated through a diffusion process. The advection and diffusion of the sediment is linked to the velocity of water in the reach which is calculated during the flow routing. The *Component Editor* is shown in Figure 400.

Basin Name: North Bosque Calibration	
Element Name: NFRIVER50	
*Clay Dispersion (FT <sup>2</sup> /S)	28
*Clay Travel (HR)	2.7
*Silt Dispersion (FT <sup>2</sup> /S)	32
*Silt Travel (HR)	3.5
*Sand Dispersion (FT <sup>2</sup> /S)	105
*Sand Travel (HR)	7.2
*Gravel Dispersion (FT <sup>2</sup> /S)	260
*Gravel Travel (HR)	22
*Initial Grad Curve:	BO 20 Reach 
Erosion Limit:	--None--
Deposition Method:	--None--
*Bed Width (FT)	10
*Bed Depth (FT)	10
*Active Layer Factor:	2

Figure 400. Fisher's dispersion sediment method editor at a reach element.

The dispersion coefficient must be specified for each grain class (clay, silt, sand, gravel). The dispersion coefficient indicates the diffusion of the particles during transit through the reach and is closely connected to channel geometry. The dispersion coefficient can vary over several orders of magnitude and often must be adjusted during calibration. Some guidance is available for estimating the dispersion coefficient, for example, Kashefipour and Falconer (2002). The travel time must also be specified for each grain class (clay, silt, sand, gravel) and is often close to the travel time for water in the reach. When the AGU 20 grain size classification is used, the same dispersion and retention values are used for all subclasses of a grain class.

The initial gradation curve defines the distribution of the bed sediment by grain size at the beginning of the simulation. The same curve is used in both the upper and lower layers of the two-layer bed model. The gradation curve is defined as a diameter-percentage function in the *Paired Data Manager*. The current functions are shown in the selection list. If there are many different functions available, you may wish to choose a function from the selector accessed with the paired data button next to the selection list. The selector displays the description for each function, making it easier to select the correct one.

Using an erosion limit is optional. When the erosion limit is deactivated, erosion is limited only by the transport capacity of the flow. When the erosion limit is activated, actual erosion is reduced when the ratio of reach length to flow depth is less than 30. The erosion limit is usually encountered only in very short reaches.

Using a deposition limit is optional. When the deposition limit is deactivated, sediment in excess of the transport capacity is deposited completely. When the deposition limit is activated, sediment is limited by the flow depth calculated during flow routing and the fall velocity of each grain size. The fall velocity is computed using the method selected with the basin model properties. Using a deposition limit requires the specification of the water temperature in the reach. You may specify a fixed temperature or select a temperature time-series gage. Temperature gages must be created in the *Time-Series Data Manager* before they can be used for the sediment method.

The width of the sediment bed must be specified. The width should be typical of the reach and is used in computing the volume of the upper and lower layers of the bed model. The depth of the bed must also be specified. The depth should be typical of the total depth of the upper and lower layers of the bed, representing the maximum depth of mixing over very long time periods.

The active layer factor is used to calculate the depth of the upper layer of the bed model. At each time interval, the upper layer depth is

computed as the  $d_{90}$  of the sediment in the upper layer, multiplied by the active layer factor.

### **Linear Reservoir**

The linear reservoir method uses a simple linear reservoir to route each grain size through the reach. For each time interval, available sediment is calculated from the upstream sediment and local erosion or deposition. The available sediment in each grain size class is routed through a linear reservoir independently of the hydrologic routing of the flow. This allows sediment of different grain sizes to move at different speeds through the reach. Calibration with observed data significantly improves the results. The *Component Editor* is shown in Figure 401.

The retention parameter is equivalent to the storage coefficient in the linear reservoir used to route the sediment through the reach. The routing is performed separately for clay, silt, sand, and gravel. When the AGU 20 grain size classification is used, the same retention is used for all subclasses of each class. The value of the retention parameter is analogous to the median length of time for each sediment class to transit the reach. It may change for each sediment size class but is often close to the travel time for water in the reach.

Basin Name: North Bosque Calibration	
Element Name: NFRIVER50	
*Clay Retention (HR)	2.7
*Silt Retention (HR)	3.5
*Sand Retention (HR)	7.2
*Gravel Retention (HR)	22
*Initial Grad Curve:	BO 20 Reach
Erosion Limit:	Length-Depth Ratio
Deposition Method:	EffectiveDepth
Temperature Method:	Time-Series
Temperature Gage:	BO 20
*Bed Width (FT)	10
*Bed Depth (FT)	10
*Active Layer Factor:	2

Figure 401. Linear reservoir sediment method editor at a reach element.

The initial gradation curve defines the distribution of the bed sediment by grain size at the beginning of the simulation. The same curve is used in both the upper and lower layers of the two-layer bed model.

The gradation curve is defined as a diameter-percentage function in the *Paired Data Manager*. The current functions are shown in the selection list. If there are many different functions available, you may wish to choose a function from the selector accessed with the paired data button next to the selection list. The selector displays the description for each function, making it easier to select the correct one.

Using an erosion limit is optional. When the erosion limit is deactivated, erosion is limited only by the transport capacity of the flow. When the erosion limit is activated, actual erosion is reduced when the ratio of reach length to flow depth is less than 30. The erosion limit is usually encountered only in very short reaches.

Using a deposition limit is optional. When the deposition limit is deactivated, sediment in excess of the transport capacity is deposited completely. When the deposition limit is activated, sediment is limited by the flow depth calculated during flow routing and the fall velocity of each grain size. The fall velocity is computed using the method selected with the basin model properties. Using a deposition limit requires the specification of the water temperature in the reach. You may specify a fixed temperature or select a temperature time-series gage. Temperature gages must be created in the *Time-Series Data Manager* before they can be used for the sediment method.

The width of the sediment bed must be specified. The width should be typical of the reach and is used in computing the volume of the upper and lower layers of the bed model. The depth of the bed must also be specified. The depth should be typical of the total depth of the upper and lower layers of the bed, representing the maximum depth of mixing over very long time periods.

The active layer factor is used to calculate the depth of the upper layer of the bed model. At each time interval, the upper layer depth is computed as the  $d_{90}$  of the sediment in the upper layer, multiplied by the active layer factor.

### ***Uniform Equilibrium***

The uniform equilibrium method assumes that sediment is translated instantaneously through the reach. It is the simplest method because it does not compute any temporal lag for the sediment passing through the reach. Sediment enters the reach from upstream elements. The transport capacity for each grain size is calculated to determine the deposition or erosion state. The available sediment is computed subject to the limitations on deposition and erosion. The available sediment is then passed out of the reach regardless of the velocity determined during flow routing. The *Component Editor* is shown in Figure 402.

Figure 402. Uniform equilibrium sediment method editor at a reach element.

The initial gradation curve defines the distribution of the bed sediment by grain size at the beginning of the simulation. The same curve is used in both the upper and lower layers of the two-layer bed model. The gradation curve is defined as a diameter-percentage function in the *Paired Data Manager*. The current functions are shown in the selection list. If there are many different functions available, you may wish to choose a function from the selector accessed with the paired data button next to the selection list. The selector displays the description for each function, making it easier to select the correct one.

Using an erosion limit is optional. When the erosion limit is deactivated, erosion is limited only by the transport capacity of the flow. When the erosion limit is activated, actual erosion is reduced when the ratio of reach length to flow depth is less than 30. The erosion limit is usually encountered only in very short reaches.

Using a deposition limit is optional. When the deposition limit is deactivated, sediment in excess of the transport capacity is deposited completely. When the deposition limit is activated, sediment is limited by the flow depth calculated during flow routing and the fall velocity of each grain size. The fall velocity is computed using the method selected with the basin model properties. Using a deposition limit requires the specification of the water temperature in the reach. You may specify a fixed temperature or select a temperature time-series gage. Temperature gages must be created in the *Time-Series Data Manager* before they can be used for the sediment method.

The width of the sediment bed must be specified. The width should be typical of the reach and is used in computing the volume of the upper and lower layers of the bed model. The depth of the bed must also be specified. The depth should be typical of the total depth of the upper

and lower layers of the bed, representing the maximum depth of mixing over very long time periods.

The active layer factor is used to calculate the depth of the upper layer of the bed model. At each time interval, the upper layer depth is computed as the  $d_{90}$  of the sediment in the upper layer, multiplied by the active layer factor.

### Volume Ratio

The volume ratio method links the transport of sediment to the transport of flow in the reach using a conceptual approach. For each time interval, sediment from upstream elements is added to the sediment already in the reach. The deposition or erosion of sediment is calculated for each grain size to determine the available sediment for routing. The proportion of available sediment that leaves the reach in each time interval is assumed equal to the proportion of stream flow that leaves the reach during that same interval. This means that the all grain sizes are transported through the reach at the same rate, even though erosion and deposition are determined separately for each grain size. This assumption essentially limits the advection velocity of the sediment to the bulk water velocity. Therefore, this method is a higher fidelity option than the *Equilibrium* method (without requiring much more data) but less precise than the other available methods which require substantially more data. This method is very similar to the approach used in the Soil and Water Assessment Tool model (Gassman, 2007). The *Component Editor* is shown in Figure 403.

The screenshot shows a software interface for editing sediment method parameters. At the top, there are four tabs: 'Reach', 'Routing', 'Sediment', and 'Options'. The 'Sediment' tab is selected. Below the tabs, the following information is displayed:

- Basin Name:** North Bosque Calibration
- Element Name:** NFRIVER50
- \*Initial Grad Curve:** BO 20 Reach (with a small graph icon to the right)
- Erosion Limit:** --None--
- Deposition Method:** --None--
- \*Bed Width (FT):** 10
- \*Bed Depth (FT):** 10
- \*Active Layer Factor:** 2

Figure 403. Volume ratio sediment method editor at a reach element.

The initial gradation curve defines the distribution of the bed sediment by grain size at the beginning of the simulation. The same curve is used in both the upper and lower layers of the two-layer bed model. The gradation curve is defined as a diameter-percentage function in the *Paired Data Manager*. The current functions are shown in the

selection list. If there are many different functions available, you may wish to choose a function from the selector accessed with the paired data button next to the selection list. The selector displays the description for each function, making it easier to select the correct one.

Using an erosion limit is optional. When the erosion limit is deactivated, erosion is limited only by the transport capacity of the flow. When the erosion limit is activated, actual erosion is reduced when the ratio of reach length to flow depth is less than 30. The erosion limit is usually encountered only in very short reaches.

Using a deposition limit is optional. When the deposition limit is deactivated, sediment in excess of the transport capacity is deposited completely. When the deposition limit is activated, sediment is limited by the flow depth calculated during flow routing and the fall velocity of each grain size. The fall velocity is computed using the method selected with the basin model properties. Using a deposition limit requires the specification of the water temperature in the reach. You may specify a fixed temperature or select a temperature time-series gage. Temperature gages must be created in the *Time-Series Data Manager* before they can be used for the sediment method.

The width of the sediment bed must be specified. The width should be typical of the reach and is used in computing the volume of the upper and lower layers of the bed model. The depth of the bed must also be specified. The depth should be typical of the total depth of the upper and lower layers of the bed, representing the maximum depth of mixing over very long time periods.

The active layer factor is used to calculate the depth of the upper layer of the bed model. At each time interval, the upper layer depth is computed as the  $d_{90}$  of the sediment in the upper layer, multiplied by the active layer factor.

## **Reservoir**

A reservoir provides an ideal environment for removing sediment from water. Quiescent water, or completely still water, has no capacity to suspend sediment because the horizontal velocity of the water is zero. Therefore, given enough time all sediment in the water column will settle to the bottom of the reservoir. Time is important because sediment does not settle instantaneously. There is a very small amount of friction between each sediment grain and the water molecules that surround it. This friction creates a turbulent environment that slows the descent of each sediment grain. The velocity at which a particular grain will settle is due to its size and to a lesser extent, the density and shape of the grain. Large grains will settle very quickly while small grains will settle slower. The very fine-

grained sediments such as silt and clay may require years to settle from the water column. The greater the residence time of the reservoir, the higher the percentage of the inflowing sediment will settle to the bottom. However, the very smallest clay particles may never settle due to electrical charges in the minerals composing the particles and the charges in water molecules caused by hydrogen bonding.

Sediment entering a reservoir and settling to the bottom eliminates some of the storage space of the reservoir. Over time the cumulative storage lost to sediment settling may be significant. The program will compute the sediment balance in the reservoir over time. However, the volume of sediment accumulating in the reservoir is not linked to the storage characteristics of the reservoir used for flow routing.

### **Selecting a Sediment Method**

The sediment method for a reservoir is selected on the *Component Editor* for the reservoir element (Figure 404). Access the *Component Editor* by clicking the reservoir element icon on the "Components" tab of the *Watershed Explorer*. You can also access the *Component Editor* by clicking on the element icon in the basin map, if the map is currently open. You can select a sediment method from the list of four available choices. Use the selection list to choose the method you wish to use. Each reservoir is treated separately and should use an appropriate method for the size of the reservoir compared to the inflow volume. Very large reservoirs typically trap nearly all incoming sediment. Small reservoirs often trap gravel and sand, while allowing silt and clay to pass through with some attenuation of the sediment pulses.



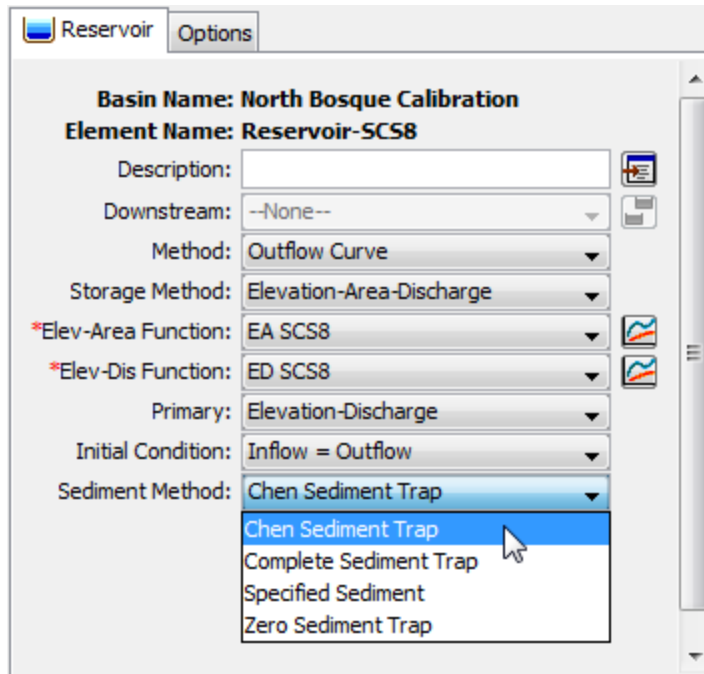

Figure 404. Selecting a sediment method for a reservoir element.

The parameters for each sediment method are presented on a separate *Component Editor* from the reservoir element editor. The "Sediment" editor is shown next to the "Reservoir" editor once a sediment method has been selected. The information shown on the sediment editor will depend on which method is currently selected, though some methods have no parameters to enter.

### **Complete Sediment Trap**

The complete sediment trap method settles all incoming sediment to the bottom of the reservoir with no sediment remaining in the outflow. This method may be used for reservoirs that have a large residence time which is sufficient for even silt and clay particles to settle. Suitability of the method may be verified by computing the settling velocity of small sediment particles, dividing the reservoir depth by the settling velocity, and comparing to the estimated residence time. A reference such as Jiménez and Madsen (2003) may be used to compute settling velocity. There are no parameters for the method.

### **Specified Sediment**

The specified sediment method uses observations of sediment at the outlet of the reservoir to compute the sediment leaving the reservoir at each time interval. The sediment observed at the outlet may be more or less than the incoming sediment during a time interval. Settling is presumed to occur when the observed sediment is less than the incoming sediment. When the observed sediment is more than the

incoming sediment, resuspension and discharge is presumed to occur. The actual physical processes are not significant; the observed sediment at the outlet of the reservoir is simply specified as a time-series. The *Component Editor* is shown in Figure 405.

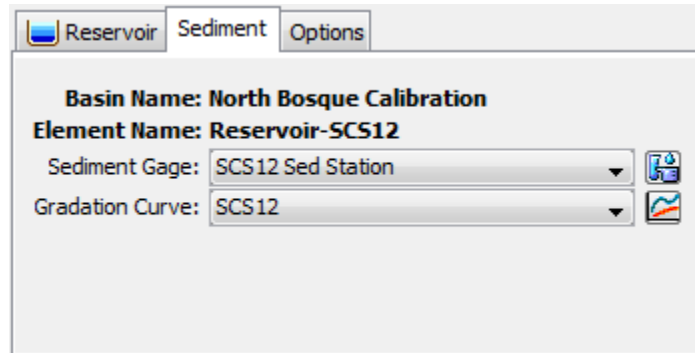

Figure 405. Specified sediment method editor at a reservoir element.

The total sediment discharge from the reservoir is specified with a time-series of sediment load. The time-series should represent the total of all grain size classes. The time-series data must be defined in the *Time-Series Data Manager* before it can be selected in the sediment editor. The time-series button next to the selection list can be used to assist in selecting the correct sediment gage.

The total sediment discharge from the reservoir is apportioned into grain size classes using a grain size distribution curve. The grain size distribution curve is specified with a diameter-percentage function. The function data must be defined in the *Paired Data Manager* before it can be selected in the sediment editor. The paired data button next to the selection list can be used to assist in selecting the correct function.

### **Chen Sediment Trap**

The trap efficiency of a reservoir is the sediment load retained in the reservoir divided by the total sediment load entering the reservoir. The trap efficiency can be estimated by comparing the settling velocity of the sediment to a critical settling velocity (Chen, 1975). The settling velocity is computed using the method selected for the basin model. The critical settling velocity is computed as the discharge rate from the reservoir divided by the surface area. The computations are performed separately for each grain size class or subclass. In order to compute the surface area for each time interval of the simulation, this method can only be used if the reservoir storage characteristics are specified with the elevation-area method. The *Component Editor* is shown in Figure 406.

Figure 406. Chen sediment trap method editor at a reservoir element.

The only parameter for the Chen sediment trap method is the depth-averaged temperature of the water in the reservoir. You may specify a fixed temperature or select a temperature time-series gage.

Temperature gages must be created in the *Time-Series Data Manager* before they can be used for the sediment method.

### **Zero Sediment Trap**

The zero sediment trap method passes all incoming sediment to the outlet with no settling. The incoming sediment load for each grain size is totaled for the upstream elements at the end of each time interval. The total time interval sediment load for each grain size class is then transferred to the outlet of the reservoir. No settling happens for any of the grain size classes during the time interval. This may lead to large differences in the sediment concentration at the inlet and outlet of the reservoir if the inflow rate is different from the discharge rate. This method is only recommended for very small reservoirs with a residency time approximately equal to the simulation time interval. There are no parameters for the method.

## **Source**

A source element provides a way to introduce inflow to the channel network. Usually the inflow represents a portion of the upstream watershed that is not explicitly modeled in the basin model. Sometimes the inflow is computed in a separate simulation model, where the outflow hydrograph from that model becomes the inflow at the source element. Other times the inflow is observed at a flow measurement station and becomes the inflow at the source element. It is critical in a basin model that contains a source element to introduce both the water and sediment inflow at the source.

### **Selecting a Sediment Method**

The sediment method for a source is selected on the *Component Editor* for the source element (Figure 407). Access the *Component*

*Editor* by clicking the source element icon on the "Components" tab of the *Watershed Explorer*. You can also access the *Component Editor* by clicking on the element icon in the basin map, if the map is currently open. You can select a sediment method from the list of three available choices. If you choose the `None` method, the source will not compute any sediment and all sediment discharges from the element will be zero. Use the selection list to choose the method you wish to use. Each source is treated separately and should use an appropriate method for the area of the watershed above the source and the duration of the simulation.

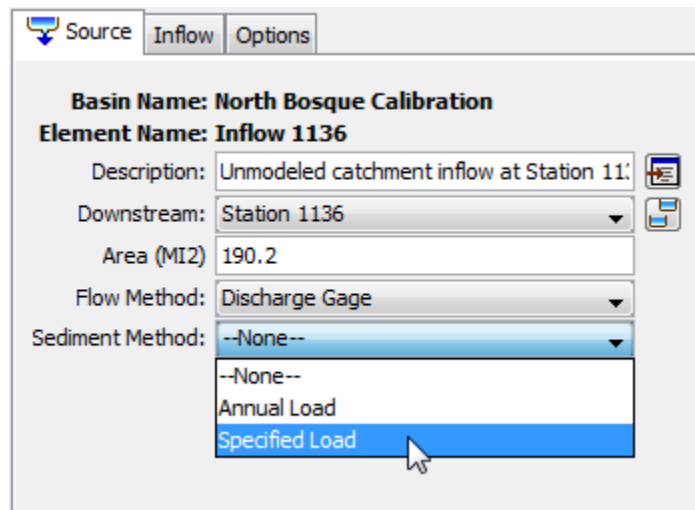

Figure 407. Selecting a sediment method for a source element.

The parameters for each sediment method are presented on a separate *Component Editor* from the source element editor. The "Sediment" editor is shown next to the "Inflow" editor once a sediment method has been selected. The information shown on the sediment editor will depend on which method is currently selected.

### **Annual Load**

The annual load method applies an average annual sediment load to the discharge hydrograph with a methodology that may be suitable for continuous simulation applications where the land use is not changing in time. The total load must be distributed into a time-series in a manner that is consistent with the outflow hydrograph at the source. The method adopted in the program is to use an exponential form developed by Haan *et al.* (1994). The exponential equation is given by

$$c_t = kQ_t^a$$

where  $c_t$  is the sediment concentration at time  $t$ ,  $k$  is the ratio of the total sediment load for the time window to the total discharge for the

time window,  $Q_t$  is the source discharge at time  $t$ , and  $a$  is an exponent entered by the user. The *Component Editor* is shown in Figure 408.

Figure 408. Annual load sediment method editor at a source element.

The total load specifies the accumulated sediment over all grain size classes for a typical year. The total load depends on the land use of the area upstream of the source element and can be highly variable due to local conditions. The load is fixed for the simulation time window.

The exponent is used to distribute the sediment load into a time-series sedigraph. A small value flattens the sedigraph compared to the hydrograph. A large value heightens the sedigraph compared to the hydrograph.

The gradation curve defines the distribution of the total sediment load into grain size classes and subclasses. The gradation curve is defined as a diameter-percentage function in the *Paired Data Manager*. The current functions are shown in the selection list. If there are many different functions available, you may wish to choose a function from the selector accessed with the paired data button next to the selection list. The selector displays the description for each function, making it easier to select the correct one.

### **Specified Load**

The specified sediment method uses observed sediment load time-series data to determine the sediment to add to the flow at the source element. Observations of sediment are less common than observations of stream flow. In cases where observations are not available at the location of the source element, this method could be used for sediment computed from an external model of sediment discharge. The *Component Editor* is shown in Figure 409.

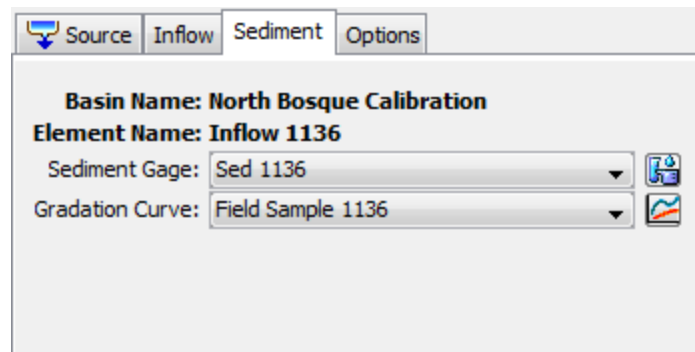

Figure 409. Specified load sediment method editor at a source element.

The total sediment discharge at the source is specified with a time-series of sediment load. The time-series should represent the total of all grain size classes. The time-series data must be defined in the *Time-Series Data Manager* before it can be selected in the sediment editor. The time-series button next to the selection list can be used to assist in selecting the correct sediment gage.

The total sediment discharge at the source is apportioned into grain size classes using a grain size distribution curve. The grain size distribution curve is specified with a diameter-percentage function. The function data must be defined in the *Paired Data Manager* before it can be selected in the sediment editor. The paired data button next to the selection list can be used to assist in selecting the correct function.

## Junction

A junction element is used to combine the outflow from multiple upstream elements in order to produce one outflow. The outflow from the junction is usually connected downstream to a reach or other elements. All water that enters a junction must leave the junction because no water is stored at the junction. Therefore, all of the inflows to the junction are added together in order to compute the total inflow hydrograph to the junction. Similarly, all sediment in each of the inflows is added to compute the total sedigraph. The total inflow hydrograph and total inflow sedigraph are connected to the downstream element.

## Diversion

A diversion element is used to represent a hydraulic control structure that directs some of the stream flow out of the channel and into a storage pond or side channel. The diversion method calculates the amount of flow to be diverted and subtracts it from the inflow to the element. The diverted flow may be connected to a downstream

location in the channel network. After the diverted flow is subtracted from the inflow, the remaining flow continues downstream through the channel network. Sediment is managed in much the same manner. The inflow to the diversion element is accompanied by sediment entering the element. Some of the sediment may be taken with the diverted flow. The remaining sediment continues downstream with the channel flow that passes through the diversion element. The physical properties of the diversion structure control the amount of sediment that goes with the diverted flow as compared to the amount of sediment remaining in the channel.

### Selecting a Sediment Method

The sediment method for a diversion is selected on the *Component Editor* for the diversion element (Figure 410). Access the *Component Editor* by clicking the diversion element icon on the "Components" tab of the *Watershed Explorer*. You can also access the *Component Editor* by clicking on the element icon in the basin map, if the map is currently open. You can select a sediment method from the list of three available choices. If you choose the `None` method, the source will not compute any sediment and all sediment discharges from the element will be zero. Use the selection list to choose the method you wish to use. Each diversion is treated separately and should use an appropriate method for the configuration of the diversion structure and its ability to pass sediment with the diverted flow.

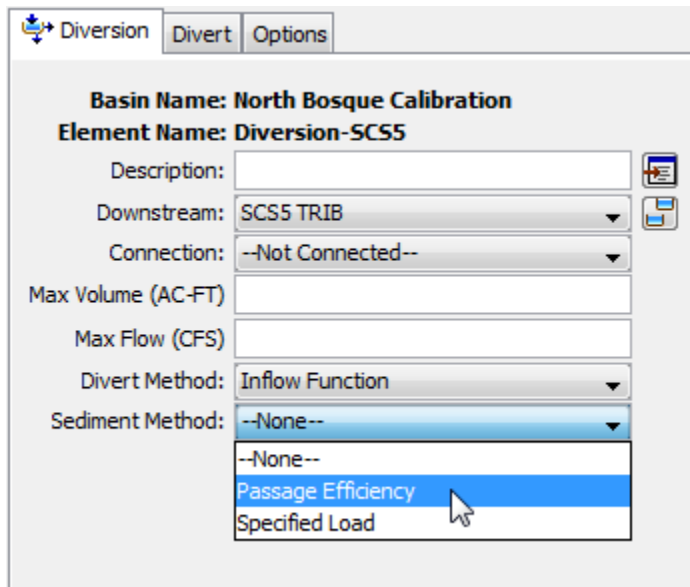

Figure 410. Selecting a sediment method for a diversion element.

The parameters for each sediment method are presented on a separate *Component Editor* from the diversion element editor. The "Sediment" editor is shown next to the "Divert" editor once a sediment

method has been selected. The information shown on the sediment editor will depend on which method is currently selected.

### **Passage Efficiency**

Diversion structures are usually designed primarily to control the movement of water, redirecting some portion of the inflow away from the main channel. In general the  $d_{50}$  of the sediment in the diverted flow is smaller than the  $d_{50}$  of the sediment in the main channel. The passage efficiency method provides a simple approach to controlling the differential sediment movement that typically occurs at diversion structures. The *Component Editor* is shown in Figure 411.

The clay percentage in the diverted flow must be specified. The incoming clay load to the diversion element is converted to a concentration. Subsequently the clay concentration in the diverted flow is calculated as the incoming concentration multiplied by the specified percentage. A mass balance is then performed in order to calculate the load in the diverted flow and the load remaining in the channel. When the AGU 20 grain size classification is used, the same percentage is used for all subclasses of clay.

Basin Name: North Bosque Calibration	
Element Name: Diversion-SCS5	
*Clay (%)	98
*Silt (%)	90
*Sand (%)	28
*Gravel (%)	2

Figure 411. Passage efficiency sediment method editor at a diversion element.

The silt percentage in the diverted flow must be specified. The silt percentage may be close to the clay percentage if the velocity through the diversion structure is high. When the AGU 20 grain size classification is used, the same percentage is used for all subclasses of silt.

The sand percentage in the diverted flow must be specified. Unless the diversion structure is specifically designed to direct sediment from the main channel, the sand percentage will be much smaller than the percentage for clay and silt. When the AGU 20 grain size classification is used, the same percentage is used for all subclasses of sand.

The gravel percentage in the diverted flow must be specified. The percentage for gravel is often close to zero. When the AGU 20 grain



size classification is used, the same percentage is used for all subclasses of gravel.

### **Specified Load**

The specified sediment method uses observed sediment load time-series data to determine the sediment to remove from the inflow to the diversion element and transfer with the diverted flow. Remaining sediment remains in the channel and continues to be routed downstream of the diversion. If observations of sediment are not available where the diverted flow is discharged out of the channel, then an external model could be used to compute the sediment load. The *Component Editor* is shown in Figure 412.

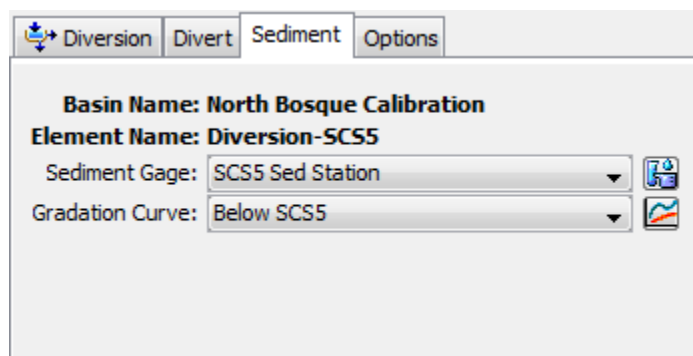

Figure 412. Specified load sediment method editor at a diversion element.

The total sediment discharge for the diverted flow is specified with a time-series of sediment load. The time-series should represent the total of all grain size classes. The time-series data must be defined in the *Time-Series Data Manager* before it can be selected in the sediment editor. The time-series button next to the selection list can be used to assist in selecting the correct sediment gage.

The total sediment discharge in the diverted flow is apportioned into grain size classes using a grain size distribution curve. The grain size distribution curve is specified with a diameter-percentage function. The function data must be defined in the *Paired Data Manager* before it can be selected in the sediment editor. The paired data button next to the selection list can be used to assist in selecting the correct function.

## **Sink**

A sink element is used to mark the outlet of a watershed model. No water leaves the sink. Therefore, all of the inflows to the sink are added together in order to compute the total inflow hydrograph to the sink. Just as water cannot leave the sink, sediment also cannot leave

the sink. Similar to the water, all sediment in each of the inflows is added to compute the total sedigraph.

## **Viewing Erosion and Sediment Results**

The primary results from erosion and sediment components are time-series. Available results depend on the type of element, but always include the total sediment load leaving the element. The total sediment is also separated out by grain size class or subclass. These results are accessed in the *Watershed Explorer* on the "Results" tab. When erosion and sediment components are activated, a special folder for erosion and sediment results is added under each element icon.

All of the erosion and sediment time-series data computed by an individual element are available for viewing. Click on a time-series node to preview the data in the *Component Editor*. You may select multiple time-series data by holding the shift or control key while using the mouse to click on additional nodes. The selected time-series may come from different elements in the same simulation, or the same element in different simulations. Results can also be combined from different types of simulations including simulation runs, optimization trials, depth-area analyses, and forecast alternatives. The selected time-series data will automatically be partitioned into groups by data type if the erosion and sediment results are combined with other types of results such as flow or stage.

## Subbasin

The erosion results for each subbasin include the time-series of total sediment load leaving the subbasin. The total sediment is the sum of all grain size classes. Also included is the time-series of sediment load in each grain size class. The total sediment concentration in the outflow is also included among the results. The organization of the results is shown in Figure 413.

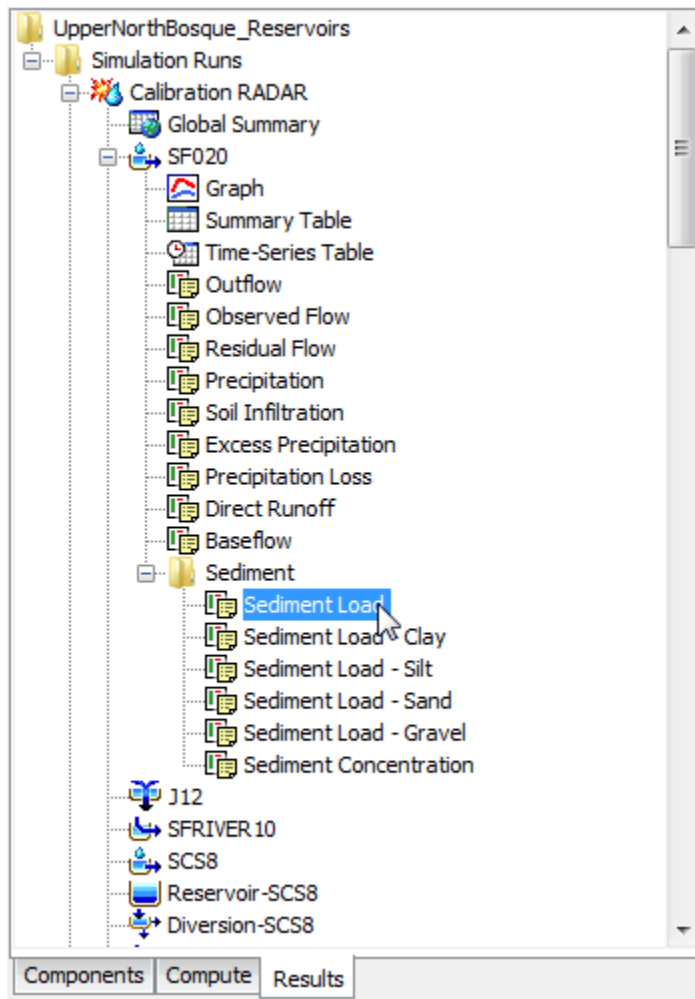

Figure 413. Sediment results for a subbasin element.

### Reach

The sediment results for each reach include the time-series of total sediment load entering the reach, and the total sediment load leaving the reach. The total sediment is the sum of all grain size classes. Also included is the time-series of sediment load in each grain size class both coming into the reach and leaving the reach. The organization of the results is shown in Figure 414.

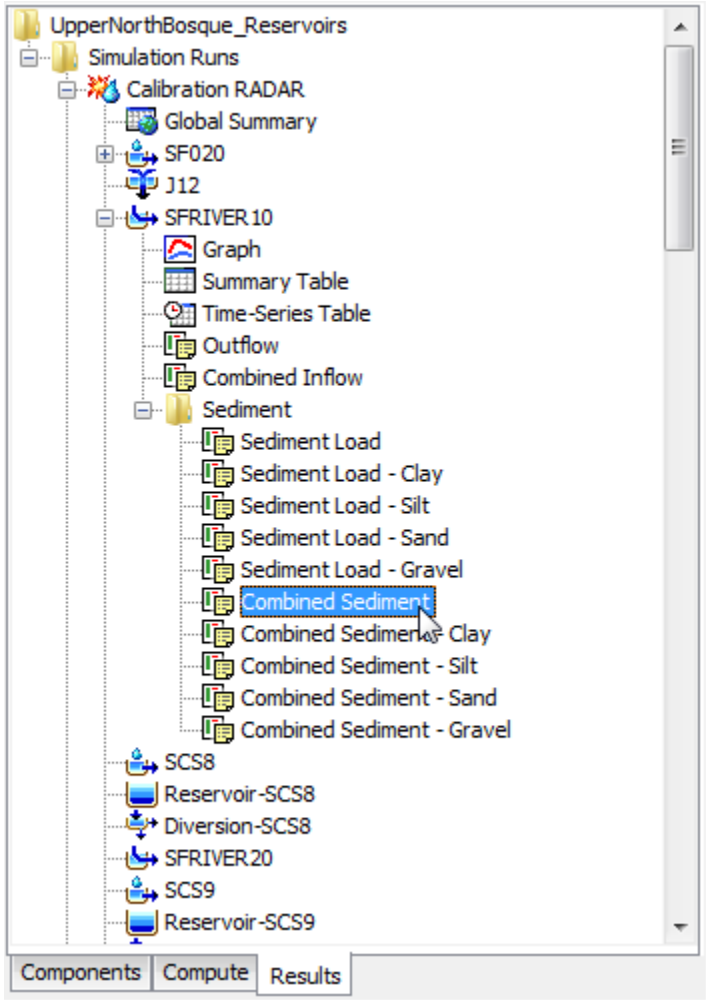

Figure 414. Sediment results for a reach element.

## Reservoir

The sediment results for each reservoir include the time-series of total sediment load entering the reservoir, and the total sediment load leaving the reservoir. Additionally, the time-series of total sediment load settled to the bottom of the reservoir is available, along with the time-series of sediment load in suspension in the reservoir pool. For each of the four categories, the total sediment is the sum of all grain size classes. Also included is the time-series of sediment load in each grain size class for each of the four categories of sediment at a reservoir. The organization of the results is shown in Figure 415.

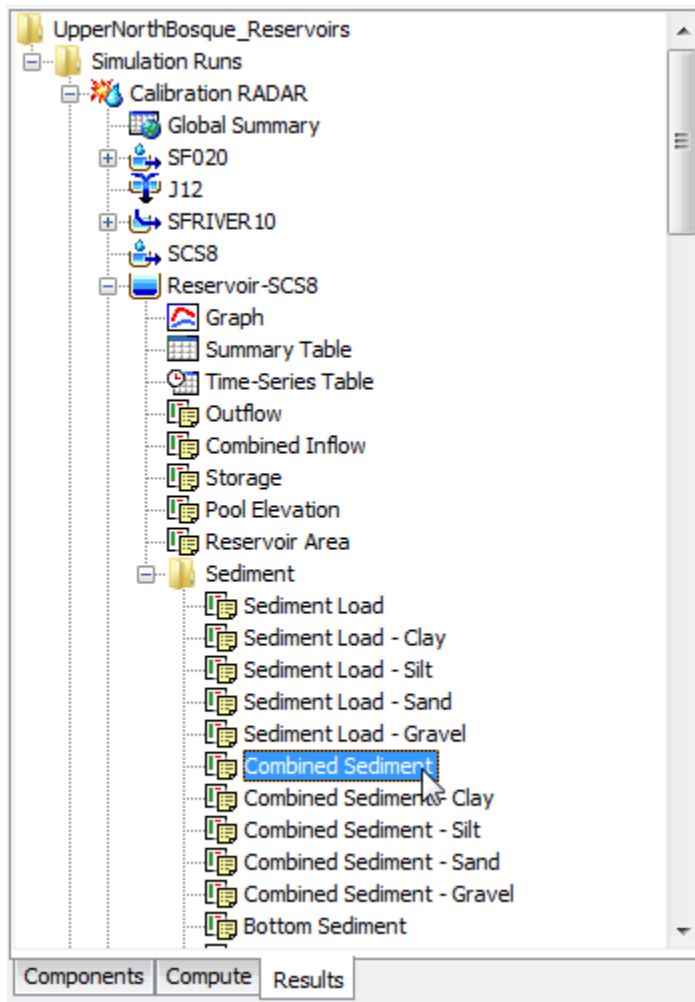

Figure 415. Sediment results for a reservoir element.

### **Source**

The sediment results for each source include the time-series of total sediment load leaving the source. The total sediment is the sum of all grain size classes. Also included is the time-series of sediment load within each grain size class.

### **Junction**

The sediment results for each junction include the time-series of total sediment load leaving the junction. The total sediment is the sum of all sediment from each of the upstream elements. Also included is the time-series of sediment load for each grain size class, computed similarly to the total load but specific to each grain size.

### **Diversion**

The sediment results for each diversion include the time-series of total sediment load entering the diversion, and the total sediment load leaving the diversion. The total sediment is the sum of all grain size classes. Additionally, the total sediment load in the diverted flow is available. Also included is the time-series of sediment load in each grain size class for each of the three categories of sediment at a diversion.

### **Sink**

The sediment results for each sink include the time-series of total sediment load entering the sink. The total sediment is the sum of all sediment from each of the upstream elements. Also included is the time-series of sediment load for each grain size class, computed similarly to the total load but specific to each grain size.

## **References**

- Ackers, P. and W.R. White. 1973. "Sediment Transport: New Approach and Analysis." *Journal of the Hydraulics Division*, vol 99, no HY11, pp 2040-2060.
- Breault, R.F., K.P. Smith, and J.R. Sorenson. 2005. *Residential Street-dirt Accumulation Rates and Chemical Composition, and Removal Efficiencies by Mechanical- and Vacuum-type Sweepers, New Bedford, Massachusetts, 2003-04*. U.S. Geological Survey, Scientific Investigations Report 2005-5184.
- Chen, C.N. 1975. "Design of Sediment Retention Basins." *Proceedings of the National Symposium on Urban Hydrology and Sediment Control*, pp 285-298.

Copeland, R.R. and W.A. Thomas. 1989. *Corte Madera Creek Sedimentation Study, Numerical Model Investigation*. U.S. Army Corps of Engineers, Waterways Experiment Station, Technical Report HL-89-6.

Engelund, F. and E. Hansen. 1967. *A Monograph on Sediment Transport in Alluvial Streams*. Danish Technical University, Hydraulics Laboratory.

Fischer, H.B., E.J. List, R.C.Y. Koh, J. Imberger, and N.H. Brooks. 1979. *Mixing in Inland and Coastal Waters*. Academic Press, San Diego.

Gassman, P.W., M.R. Reyes, C.H. Green, and J.G. Arnold. 2007. "The Soil and Water Assessment Tool: Historical Development, Applications, and Future Research Directions." *Transactions of the ASABE*, vol 50, no 4, pp 1211-1250.

Haan, C.T., B.J. Barfield, and J.C. Hayes. 1994. *Design Hydrology and Sedimentology for Small Catchments*. Academic Press, New York.

Interagency Committee. 1957. *Some Fundamentals of Particle Size Analysis: A Study of Methods Used in Measurement and Analysis of Sediment Loads in Streams*. Interagency Committee on Water Resources, Subcommittee on Sedimentation, St. Anthony Falls Hydraulic Laboratory, Minneapolis, Minnesota.

Jiménez, J.A. and O.S. Madsen. 2003. "A Simple Formula to Estimate Settling Velocity of Natural Sediments." *Journal of Waterway, Port, Coastal, and Ocean Engineering*, vol 129, no 2, pp 70-78.

Kashfipour, S.M. and R.A. Falconer. 2002. "Longitudinal Dispersion Coefficient in Natural Channels." *Water Research*, vol 36, pp 1596-1608.

Krone, R.B. 1962. *Flume Studies of the Transport of Sediment in Estuarial Shoaling Processes*. Hydrologic Engineering Laboratory, University of California, Berkeley.

Laursen, E.M. 1958. "The Total Sediment Load of Streams." *Journal of the Hydraulics Division*, vol 84, no HY1, pp 1-36

Meyer-Peter, E. and R. Müller. 1948. "Formulas for Bed-Load Transport." *Proceedings of the 2<sup>nd</sup> Meeting of the International Association for Hydraulic Research*, pp 39-64.

- Parthenaides, E. 1962. *A Study of Erosion and Deposition of Cohesive Soils in Salt Water*. PhD Dissertation, University of California, Berkeley.
- Rubey, W.W. 1933. "Settling Velocities of Gravel, Sand, and Silt Particles." *American Journal of Science 5<sup>th</sup> Series*, vol 25, no 148, pp 325-338.
- Toffaleti, F.B. 1968. *A Procedure for Computation of Total River Sand Discharge and Detailed Distribution, Bed to Surface*. U.S. Army Corps of Engineers, Committee on Channel Stabilization, Technical Report 5.
- Van Rijn, L.C. 1993. *Principles of Sediment Transport in Rivers, Estuaries, Coastal Seas and Oceans*. International Institute for Infrastructural, Hydraulic, and Environmental Engineering, Delft, Netherlands.
- Wilcock, P.R. and J.C. Crowe. 2003. "Surface-based Transport Model for Mixes-Size Sediment." *Journal of Hydraulic Engineering*, vol 129, no 2, pp 120-128.
- Williams, J.R. 1975. "Sediment-yield Prediction with Universal Equation Using Runoff Energy Factor." In *Present and Prospective Technology for Predicting Sediment Yield and Sources: Proceedings of the Sediment Yield Workshop*. USDA Sedimentation Laboratory, Oxford, Mississippi.
- Yang, C.T. 1984. "Unit Stream Power Equation for Gravel." *Journal of the Hydraulics Division*, vol 110, no 12, pp 1783-1797.



## CHAPTER 18

# ***Water Quality***

Water flowing over the land surface comes in contact with soil and organic matter. Many different chemical compounds are present in the soil and may dissolve upon contact with the water and subsequently be carried along with the water to the catchment outlet. The organic matter is constantly decomposing, and in the process, various chemical compounds are released and may also be entrained in the surface flow. Catchment outflows enter the channel and move downstream. As water moves down the stream channel, the chemical compounds carried along in the water undergo transformations mediated by algae and bacteria. Nutrients of nitrogen and phosphorus are particularly noteworthy among the various chemical compounds. The algae and bacteria communities respond to the nutrients and key water quality criteria such as dissolved oxygen are impacted. This and other water quality criteria are closely linked to the presence and movement of water and are best evaluated in conjunction with the watershed hydrology. At this time, water quality evaluations are limited to the nutrients nitrogen and phosphorus.

### ***Nutrient Processes Affecting Water Quality***

The water quality of a watershed begins with the quality of water entering the stream channel. The quality of the inflow to the channel is often closely related to the land uses adjacent to the channel. Runoff from natural forest and meadow ecosystems may contain nitrogen and phosphorus from the decomposition of dead vegetation. However, the nutrient concentrations from these sources are usually small because the nutrients released by decomposition are typically taken up directly by natural vegetation. Runoff from agricultural lands includes nitrogen and phosphorus from the natural decomposition of dead crop plants as well as fertilizer. Excessive fertilizer application rates can significantly increase nutrients in the runoff. Runoff from urban areas includes nitrogen and phosphorus from backyard fertilizer application. The actual concentration of nitrogen and phosphorus species in surface runoff can vary widely according to local land use practices.

Algae are at the heart of nutrient processes in the water column of the stream, and are generally assumed to be suspended in the water. The algae consume nitrogen in its ammonia and nitrate forms, along with phosphorus in the inorganic form. In turn the algae release organic nitrogen and organic phosphorus back into the water column. The

algae consume dissolved oxygen in respiration and release oxygen back to the water column during primary production. Without oxygen dissolving from the atmosphere into the water column, the net effect of nutrient cycles would be to extract all dissolved oxygen from the water column. When the algae die they will settle to the bottom of the stream and become part of the sediment bed.

Algae are not the only consumers of the dissolved oxygen in the water column. Various types of dead plant matter and organisms in the water column are decomposed by bacteria. This decomposition process converts the organic nitrogen (plant matter and organisms) to ammonia. The ammonia is converted to nitrite and the nitrite is very rapidly converted to nitrate. A similar but simpler process happens with phosphorus as the organic form is converted to the inorganic form. The carbonaceous biological oxygen demand (CBOD) represents the oxygen demanding equivalent of the carbonaceous material present in the water column. A portion of the organic nitrogen and organic phosphorus settles to the stream bed and decomposes there instead of suspended in the water column. A similar decomposition process happens in the sediment bed, which also requires dissolved oxygen. A sediment oxygen demand (SOD) represents the dissolved oxygen consumed by the oxidation of organic matter in the sediment bed. Through various processes, ammonia and inorganic phosphorus are released from the sediment bed up into the water column.

The biological and chemical processes affecting the concentration of nitrogen (organic, ammonia, nitrite, nitrate) and phosphorus (organic and inorganic) interact in complex feedback loops. These interactions are summarized in Figure 416. While a number of mathematical formulations have been proposed for the pathways shown in Figure 416, only one formulation is available within the program. Details on the specific formulation used to represent the processes can be found in Zhang and Johnson (2012). The same formulations are used throughout the channel network whenever the nutrients in the water column may undergo biological and chemical processes. In general these processes are limited to reaches and reservoirs.

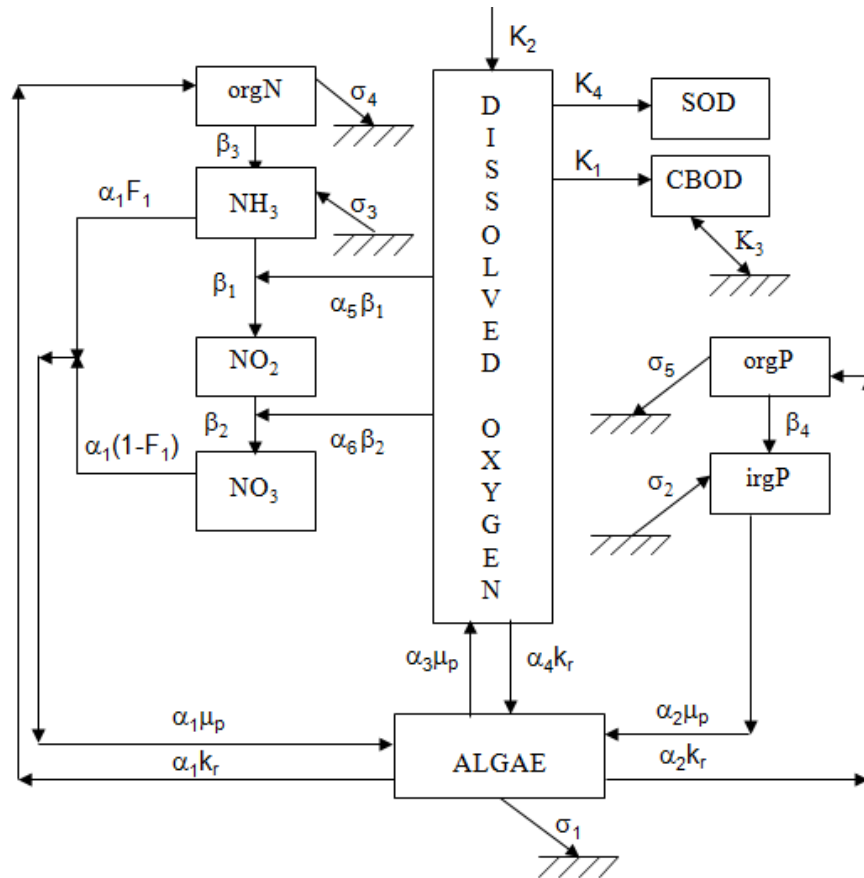

Figure 416. A schematic representation of the biological and chemical processes at work in the water column (Zhang and Johnson, 2012).

## Watershed Chemical Properties

Water quality is an optional component in the basin model. By default, the component features are deactivated and the data entry tools for water quality are not visible in the program interface, and no water quality results are computed during a simulation. The features become accessible when they are activated for the basin model. Activate the features on the *Component Editor* by clicking the basin model icon on the "Components" tab of the *Watershed Explorer*. Use the selection list to switch between activating and deactivating the water quality features. When the features are turned on, you must make selections and enter parameter data at each element in the basin model. When the features are deactivated, all parameter data for the water quality methods are deleted from the basin model and its elements. Once the water quality components have been deactivated, it is not possible to recover the deleted settings or parameter values.

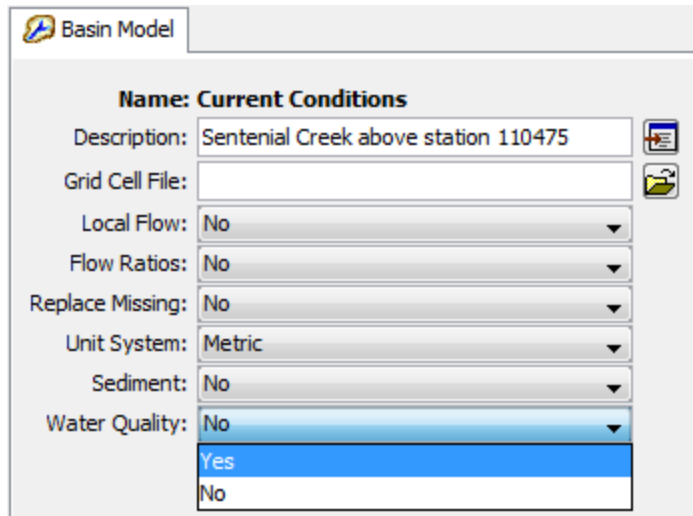

Figure 417. Activating the water quality features in the basin model.

Water quality modeling requires many chemical and biological parameters to be specified. These parameters are applied to all elements in the basin model. The properties are presented using five separate component editors: nitrogen, phosphorus, algae, dissolved oxygen (DO), and carbonaceous biological oxygen demand (CBOD). The editors are presented along with the basin model *Component Editor* as shown in Figure 418.

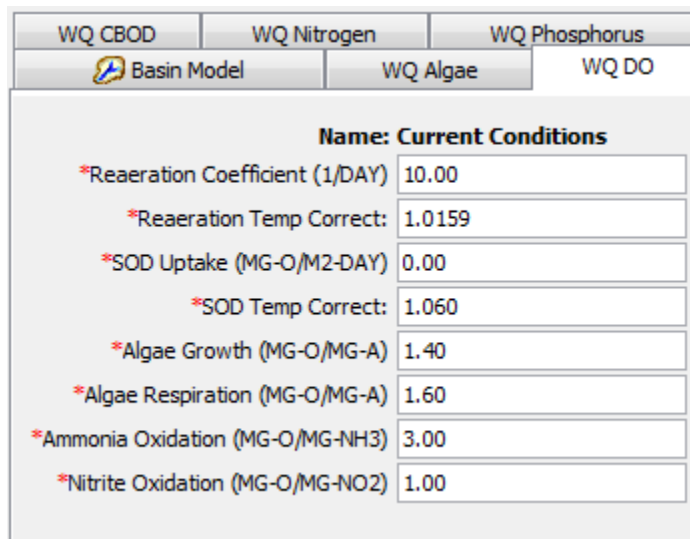

Figure 418. Specifying dissolved oxygen properties that will be applied to all elements within the basin model.

Due to the complexity of the nutrient water quality modeling, default values are provided for each of the parameters. The applicability of the default values should be verified with local conditions for each new application study. A description of the parameters and recommendations for default values can be found in Zhang and

Johnson (2012). A summary of the parameters is shown in Table 39, Table 40, and Table 41.

*Table 39. Nitrogen and phosphorus parameters used in water quality modeling.*

<b>Section</b>	<b>Parameter</b>	<b>Definition</b>	<b>Default</b>
Nitrogen	Ammonia Oxidation	Oxidation rate of ammonia to nitrite.	0.10
	Ammonia Oxidation T-Correct	Ammonia oxidation temperature correction coefficient.	1.083
	Nitrite Oxidation	Oxidation rate of nitrite to nitrate.	0.20
	Nitrite Oxidation T-Correct	Nitrite oxidation temperature correction coefficient.	1.047
	Organic Nitrogen Hydrolysis	Hydrolysis rate of organic nitrogen to ammonia.	0.20
	Organic N Hydrolysis T-Correct	Organic nitrogen hydrolysis temperature correction coefficient.	1.047
	Benthos Ammonia Release	Rate of ammonia release from stream bed to water column	0.0
	Benthos Ammonia T-Correct	Benthos ammonia release temperature correction coefficient.	1.074
	Organic Nitrogen Settling	Settling rate for organic nitrogen in the water column going to the stream bed.	0.001
	Organic N Settling T-Correct	Organic nitrogen settling temperature correction coefficient.	1.024
Phosphorus	Organic Phosphorus Decay	Decay rate for organic phosphorus to dissolved phosphorus.	0.01
	Organic Phosphorus Decay T-Correct	Organic phosphorus decay temperature correction coefficient.	1.047
	Benthos Phosphorus Release	Rate for inorganic phosphorus entering water column from stream bed.	0.0

Table 39. *Continued*

<b>Section</b>	<b>Parameter</b>	<b>Definition</b>	<b>Default</b>
Phosphorus	Benthos Phosphorus Release T-Correct	Benthos phosphorus temperature correction coefficient.	1.074
	Organic Phosphorus Settling	Settling rate for organic phosphorus in the water column going to the stream bed.	0.001
	Organic Phosphorus Settling T-Correct	Organic phosphorus settling rate temperature correction coefficient.	1.024

Table 40. *Algae and dissolved oxygen parameters used in water quality modeling.*

<b>Section</b>	<b>Parameter</b>	<b>Definition</b>	<b>Default</b>
Algae	Chlorophyll to Algae	Ratio of chlorophyll-a to algae mass.	10.0
	Fraction Nitrogen	Fraction of algae biomass that is nitrogen.	0.07
	Fraction Phosphorus	Fraction of algae biomass that is phosphorus.	0.01
	Algae Growth	Maximum algae growth rate.	1.0
	Algae Growth T-Correct	Algae growth temperature correction coefficient.	1.047
	Algae Respiration	Rate for release of organic nutrients from algae to the water column.	0.05
	Algae Respiration T-Correct	Algae respiration temperature correction coefficient.	1.047
	Algae Settling	Algae settling velocity for algae going from water column to stream bed.	0.5
	Algae Settling T-Correct	Algae settling temperature correction coefficient.	1.024
	Light Half-Saturation	Michaelis-Menton half saturation constant for light.	0.02

Table 40. Continued

Section	Parameter	Definition	Default
Algae	Nitrogen Half-Saturation	Michaelis-Menton half saturation constant for nitrogen.	0.01
	Phosphorus Half-Saturation	Michaelis-Menton half saturation constant for phosphorus.	0.01
	Ammonia Preference	Algae preference for ammonia.	1.0
	Non-Algae Self-Shading	Light extinction coefficient.	0.0
	Algae Linear Shading	Linear coefficient for algae self-shading.	0.002
	Algae Nonlinear	Nonlinear coefficient for algae self-shading.	0.0165
	DO	Reaeration Coefficient	Reaeration from atmosphere to water column.
Reaeration T-Correct		Reaeration temperature correction coefficient.	1.0159
SOD Uptake		Sediment oxygen demand uptake rate.	0.0
SOD Uptake T-Correct		Sediment oxygen demand temperature correction coefficient.	1.06
Algae Growth		Oxygen production by algae.	1.40
Algae Respiration		Oxygen consumption by algae.	1.60
Ammonia Oxidation		Oxygen consumption during oxidation of ammonia to nitrite.	3.0
Nitrite Oxidation		Oxygen consumption during oxidation of nitrite to nitrogen.	1.0

Table 41. Carbonaceous biological oxygen demand (CBOD) parameters used in water quality modeling.

Section	Parameter	Definition	Default
CBOD	CBOD Decay	Rate at which carbonaceous BOD is oxidized in the water column.	0.02
	CBOD Decay T-Correct	CBOD decay temperature correction coefficient.	1.047
	CBOD Settling	Rate at which carbonaceous BOD settles from the water column to the stream bed.	0.0
	CBOD Settling T-Correct	Carbonaceous BOD settling temperature correction coefficient.	1.047

Many of the parameters used for water quality modeling are sensitive to temperature. The reactions are assumed to happen at the water temperature and provision is made for specifying the temperature for each element. Temperature dependence requires the parameters be adjusted as the temperature changes. The formula is used to adjust the parameter value as a function of temperature is given as:

$$k(T) = k(20)\theta^{T-20}$$

where  $k$  is a parameter that depends on temperature,  $T$  is the current water temperature,  $k(20)$  is the standard parameter value at 20C, and  $\theta$  is a temperature correction coefficient specific to each parameter. If a parameter shows temperature dependence, the temperature correction coefficient is given immediately following the parameter in the *Component Editor*.

## Subbasin

The water quality in streams begins not in the streams, but on the land surface adjacent to the streams. This is the portion of the watershed that is represented by subbasin elements. Many physical processes are continuously happening on the land surface and determine the quality of the water leaving the subbasins and entering the stream channel. These processes occur naturally but may be affected by land use alterations.

Many watersheds contain plants growing on the landscape. Natural plant communities include forests and grasslands. Some areas may have been converted to agricultural production. In both cases, plants



extract nutrients (nitrogen and phosphorus) from the soil and convert the nutrients to live organic matter. Agricultural production may include the application of natural or synthetic fertilizers that contain nitrogen and phosphorus components, increasing the amount of nutrients above natural levels. When the plants die, the organic matter remains on the soil surface where the decay process begins. Products of the decay process include various forms of nitrogen and phosphorus. These products may be entrained in infiltrating precipitation replenishing the nutrient stores in the soil. Decay products may also be entrained or dissolved in overland flow that leaves the subbasin as outflow. Nutrients entrained in outflow from land surface areas are the primary source of nutrients in the stream channel.

When performing water quality calculations, the outflow from the subbasin must also include constituent concentrations. Several methods are available for determining the concentrations to be linked with the outflow hydrograph.

### ***Selecting a Quality Method***

The water quality method for a subbasin is selected on the *Component Editor* for the subbasin element (Figure 419). Access the *Component Editor* by clicking the subbasin element icon on the "Components" tab of the *Watershed Explorer*. You can also access the *Component Editor* by clicking on the element icon in the basin map, if the map is currently open. You can select a water quality method from the list of three available choices. If you choose the `NONE` method, the subbasin will not compute any water quality results and all constituent concentrations from the element will be zero. Use the selection list to choose the method you wish to use. Each subbasin may use a different method or several subbasins may use the same method.

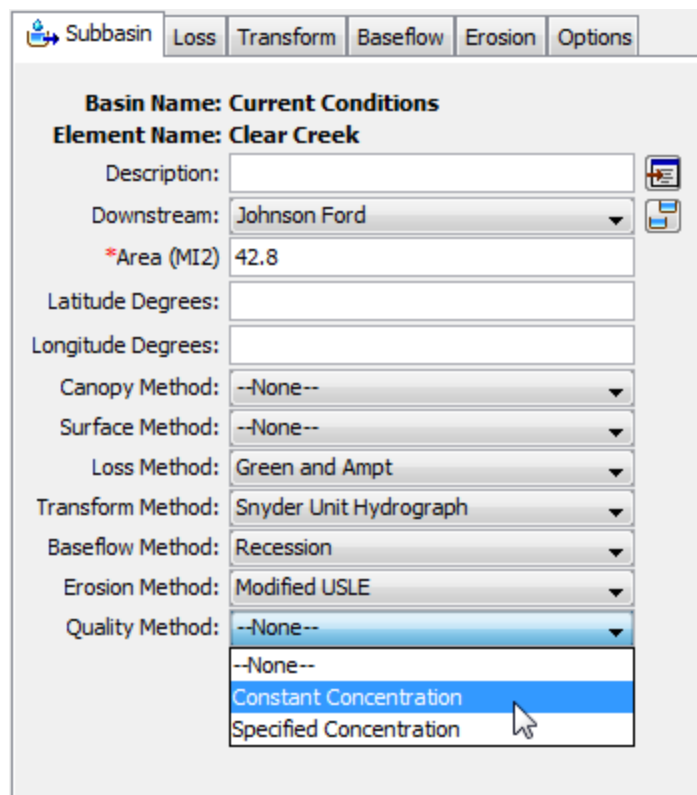

The screenshot shows a software interface for editing a subbasin element. At the top, there are tabs for 'Subbasin', 'Loss', 'Transform', 'Baseflow', 'Erosion', and 'Options'. The 'Subbasin' tab is active. Below the tabs, the 'Basin Name' is 'Current Conditions' and the 'Element Name' is 'Clear Creek'. The 'Description' field is empty. The 'Downstream' dropdown is set to 'Johnson Ford'. The '\*Area (MI2)' is 42.8. The 'Latitude Degrees' and 'Longitude Degrees' fields are empty. The 'Canopy Method' and 'Surface Method' dropdowns are set to '--None--'. The 'Loss Method' is 'Green and Ampt'. The 'Transform Method' is 'Snyder Unit Hydrograph'. The 'Baseflow Method' is 'Recession'. The 'Erosion Method' is 'Modified USLE'. The 'Quality Method' dropdown is open, showing three options: '--None--', 'Constant Concentration', and 'Specified Concentration'. A mouse cursor is pointing at 'Constant Concentration'.

Figure 419. Selecting a water quality method for a subbasin element.

The parameters for each water quality method are presented on a separate *Component Editor* from the subbasin element editor. The "Water Quality" editor is shown next to the "Erosion" editor once a water quality method has been selected. The information shown on the water quality editor will depend on which method is currently selected.

### **Constant Concentration**

The constant concentration method may be useful for simulations where steady-state conditions prevail most of the time. It may also be useful for preliminary model configuration before moving to a more advanced method. The *Component Editor* is shown in Figure 420.

Subbasin		Loss	Transform
Baseflow	Erosion	Water Quality	
<b>Basin Name: Current Conditions</b>			
<b>Element Name: Clear Creek</b>			
*Organic Nitrogen (MG/L)	13.5		
*Ammonia (MG/L)	19.2		
*Nitrite (MG/L)	9.1		
*Nitrate (MG/L)	10.9		
*Organic Phosphorus (MG/L)	0.31		
*Inorganic Phosphorus (MG/L)	0.64		
*Dissolved Oxygen (MG/L)	5.4		
*Carbonaceous BOD (MG/L)	28.1		
*Chlorophyll (MG/L)	0.004		

Figure 420. Constant concentration water quality method editor at a subbasin element.

The concentration must be specified for each of the nine parameters. The value is fixed for the time window of the simulation. The values are always specified in milligrams per liter regardless of the unit system of the basin model.

### **Specified Concentration**

The specified concentration method is designed for situations where the concentration in the outflow from a catchment is measured at a monitoring station. Alternately, it can be used if the concentration is calculated externally from the program. In either case, the user may enter a time-series of concentration for a particular constituent. The *Component Editor* is shown in Figure 421.









Subbasin		Loss	Transform
Baseflow	Erosion	Water Quality	
<b>Basin Name: Current Conditions</b>			
<b>Element Name: Clear Creek</b>			
Organic Nitrogen:	Org N at 110565		
Ammonia:	Ammonia at 110565		
Nitrite:	--None--		
Nitrate:	Nitrate at 110565		
Organic Phosphorus:	Org P at 110565		
Inorganic Phosphorus:	Inorag P at 110565		
Dissolved Oxygen:	DO at 110565		
Carbonaceous BOD:	BOD at 110565		
Chlorophyll:	CH-A at 110565		

Figure 421. Specified concentration water quality method editor at a subbasin element.

The concentration for each parameter must be specified using a time-series gage. It must be defined in the time-series manager before it can be used in the subbasin element. Select the correct gage from the list of choices for each constituent. The concentration gage type is used for all constituents, so to assist in selecting the correct gage you may wish to use the selector button next to the selection list. The selector includes the description for each available gage to assist in selecting the correct gage.

## Reach

The reach element is used for representing streams and rivers. The flow routing performed in the reach forms the basis of the water quality simulation. Results from the flow routing are used as the hydronamic field for the advection-diffusion routing of the water quality constituents.

The advection-diffusion algorithm used for routing water quality constituents is based on the QUICKEST scheme described by Leonard (1971). It is an explicit third-order accurate method, where the second-order approximation polynomial is centered on the upstream control volume. It was designed for solving problems characterized by highly advective unsteady flows, such as can be routinely found in moderate to steep sloped streams. Because of the third-order accuracy, it is possible for unrealistic undershoots and overshoots to appear in the solution, especially when steep concentration fronts are simulated. These artifacts are significantly reduced by employing the ULTIMATE scheme as part of the solution algorithm (Leonard, 1991). The combined QUICKEST-ULTIMATE solution scheme performs very well

against alternative schemes while being generally easier to implement than the alternatives (Cahyono, 1993).

The equations that physically describe the advection-diffusion process include a term generally known as the source-sink term. This source-sink term describes the increase or decrease of a constituent due to biological and chemical processes that are occurring in the water column during the transport process. In essence, the selection of a water quality method for the reach element is the selection of an appropriate method for representing the source-sink term, which will characterize the changes in a constituent in the advection-diffusion routing.

The source-sink term encapsulates a specific representation of biological and chemical process kinetics. A variety of process kinetics representations have been proposed for use in nutrient simulation and can be found in the published literature. Currently only one approach is included within the program: the Nutrient Simulation Module. The Nutrient Simulation Module (Zhang and Johnson, 2012) provides for simulation of nitrogen, phosphorus, algae, and dissolved oxygen in the water column.

### ***Selecting a Quality Method***

The water quality method for a reach is selected on the *Component Editor* for the reach element (Figure 422). Access the *Component Editor* by clicking the reach element icon on the "Components" tab of the *Watershed Explorer*. You can also access the *Component Editor* by clicking on the element icon in the basin map, if the map is currently open. You can select a water quality method from the list of two available choices. If you choose the `None` method, the reach will not compute any water quality results and all constituent concentrations from the element will be zero. Use the selection list to choose the method you wish to use. Each reach may use a different method or several reaches may use the same method.

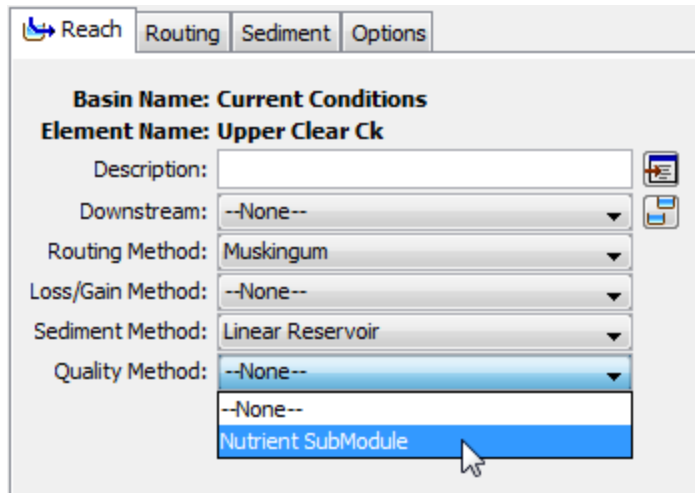
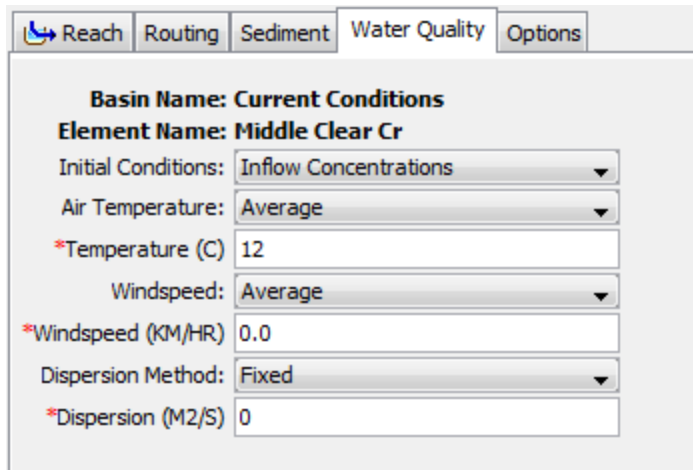

Figure 422. Selecting a water quality method for a reach element.

The parameters for each water quality method are presented on a separate *Component Editor* from the reach element editor. The "Water Quality" editor is always shown next to the "Sediment" editor. The information shown on the water quality editor will depend on which method is currently selected.

### **Nutrient Simulation Module**

The Nutrient Simulation Module includes many parameters which are used in the equations that describe the biological and chemical process kinetics. These parameter values are uniform across all elements in the basin model, and are entered in component editors that accompany the basin model. Therefore, there are no additional process kinetics parameters to enter for each reach element. However, certain initial conditions must be specified for each reach, along with meteorologic parameters necessary to compute reaeration from the air into the water. Finally, a dispersion method and parameters must be entered as shown in Figure 423.



Reach Routing Sediment **Water Quality** Options

**Basin Name: Current Conditions**  
**Element Name: Middle Clear Cr**

Initial Conditions: Inflow Concentrations ▼

Air Temperature: Average ▼

\*Temperature (C) 12

Windspeed: Average ▼

\*Windspeed (KM/HR) 0.0

Dispersion Method: Fixed ▼

\*Dispersion (M2/S) 0

Figure 423. The Nutrient Simulation Module water quality method for a reach element.

The initial water quality conditions in the reach can be set using one of two available methods. The `Inflow Concentrations` method will initialize each water quality node in the reach using the inflows to the reach element. All inflows to the reach are combined and a mass balance is performed to calculate the concentration for each state variable. The concentration at the beginning of the simulation time window is used as the initial concentration at each node in the reach. The `Specified Values` method allows you to set the concentration of each state variable independent of the concentrations in the inflow. You must enter a value for each state variable and the same value will be used as the initial concentration at each node in the reach.

The air temperature must be specified for the reach. It may be specified as an average value for the entire simulation duration. The same average value is used for each time interval of the simulation. Choose the `Average` air temperature method and enter a value. Alternatively, the temperature may be specified using a time-series gage. The gage must be defined in the time-series manager before it can be used in the reach element. Choose the `Time-Series` air temperature method and then select the correct gage from the list of choices for temperature gages.

The windspeed must be specified for the reach. It may be specified as an average value for the entire simulation duration. The same average value is used for each time interval of the simulation. Choose the `Average` windspeed method and enter a value. Alternatively, the windspeed may be specified using a time-series gage. The gage must be defined in the time-series manager before it can be used in the reach element. Choose the `Time-Series` windspeed method and then select the correct gage from the list of choices for windspeed gages.

The advection-diffusion algorithm uses a dispersion coefficient to specify the degree of diffusion as the constituents move through the reach. Three different approaches to specifying the dispersion coefficient are available. Choose the `Zero` method to specify that constituents are advected through the reach with no diffusion. Choose the `Fixed` method if you wish to specify a dispersion coefficient that remains constant for the entire simulation time window. Choose the `Computed` method to specify that the dispersion coefficient should be calculated for each time interval, but limited according to a specified minimum and maximum value. The coefficient is computed according to the equation given by Fisher *et al.* (1979) as follows:

$$K = 0.011\bar{u}^2W^2/du^*$$

where  $K$  is the dispersion coefficient,  $\bar{u}$  is the cross section mean velocity,  $W$  is the channel width, and  $du^*$  is the derivative of the shear velocity. The minimum and maximum limits are applied after the calculation.

## **Reservoir**

The reservoir element is used for representing lakes and reservoirs. The storage and outflow routing performed in the reservoir forms the basis of the water quality simulation. Results from the flow routing are used as the starting point for the simulation of the nutrients.

Nutrients in the reservoir water will undergo biological and chemical transformations while in storage. A variety of process kinetics representations have been proposed for use in nutrient simulation and can be found in the published literature. Currently only one approach is included within the program for reservoirs: the Nutrient Simulation Module. The Nutrient Simulation Module (Zhang and Johnson, 2012) provides for simulation of nutrients and dissolved oxygen in the water column.

Nutrients are suspended in the water that enters the reservoir. The water within the reservoir is assumed to be well-mixed and the nutrient concentrations are therefore assumed to be uniform throughout the water in storage. For a given time during the simulation, the nutrients in the reservoir inflow are added to the nutrient concentrations already in reservoir storage. The constituent concentrations in the storage water are updated to reflect the added nutrient mass of the inflow. The Nutrient Simulation Module is used to compute the change in each nutrient concentration according to biological and physical processes. The concentrations at the end of the process calculations are applied to the outflow determined during the flow routing. The mass of nutrients leaving the reservoir are then calculated based on a volume



ratio of the discharge and the concentrations remaining in reservoir storage are updated.

### Selecting a Quality Method

The water quality method for a reservoir is selected on the *Component Editor* for the reservoir element (Figure 424). Access the *Component Editor* by clicking the reservoir element icon on the "Components" tab of the *Watershed Explorer*. You can also access the *Component Editor* by clicking on the element icon in the basin map, if the map is currently open. You can select a water quality method from the list of two available choices. If you choose the `None` method, the reservoir will not compute any water quality results and all constituent concentrations from the element will be zero. Use the selection list to choose the method you wish to use. Each reservoir may use a different method or several reservoirs may use the same method.

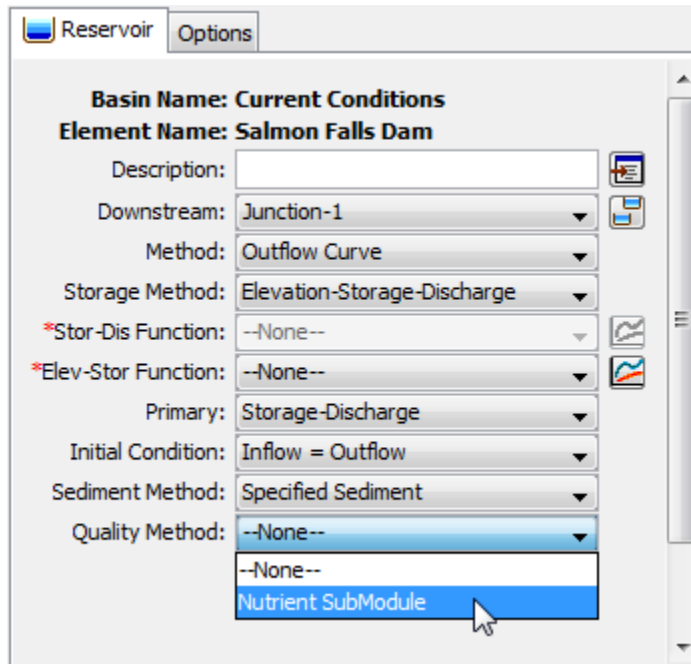

Figure 424. Selecting the water quality method for a reservoir element.

The parameters for each water quality method are presented on a separate *Component Editor* from the reservoir element editor. The "Water Quality" editor is always shown next to the "Sediment" editor. The information shown on the water quality editor will depend on which method is currently selected.

### Nutrient Simulation Module

The Nutrient Simulation Module includes many parameters which are used in the equations that describe the biological and chemical

process kinetics. These parameter values are uniform across all elements in the basin model, and are entered in component editors that accompany the basin model. Therefore, there are no additional process kinetics parameters to enter for each reach element. However, certain initial conditions must be specified for each reach, along with meteorologic parameters necessary to compute reaeration from the air into the water. Finally, a dispersion parameter must be entered.

The initial water quality conditions in the reservoir can be set using one of two available methods. The `Upstream Inflow` method will initialize the reservoir pool using the inflows to the reservoir element. All inflows to the reservoir are combined and a mass balance is performed to calculate the concentration for each state variable. The concentration at the beginning of the simulation time window is used as the initial concentration in the reservoir pool. The `Specified Values` method allows you to set the concentration of each state variable independent of the concentrations in the inflow. You must enter a value for each state variable and the same value will be used as the initial concentration in the reservoir pool.

The air temperature and the water temperature must be specified for the reservoir. The two temperatures are specified independent of each other. A temperature may be specified as an average value for the entire simulation duration. The same average value is used for each time interval of the simulation. Choose the `Constant Value` air temperature or water temperature method and enter a value. Alternatively, the temperature may be specified using a time-series gage. The gage must be defined in the time-series manager before it can be used in the reservoir element. Choose the `Time-Series` air temperature or water temperature method and then select the correct gage from the list of choices for temperature gages.

The windspeed must be specified for the reservoir. It may be specified as an average value for the entire simulation duration. The same average value is used for each time interval of the simulation. Choose the `Average` windspeed method and enter a value. Alternatively, the windspeed may be specified using a time-series gage. The gage must be defined in the time-series manager before it can be used in the reservoir element. Choose the `Time-Series` windspeed method and then select the correct gage from the list of choices for windspeed gages.

The bottom elevation must be specified for the reservoir pool. This is an effective or representative value and may not be the actual elevation at the bottom of the reservoir. The elevation is used for two separate calculations. First, the algae growth is computed by

considering the light extinction at increasing depth below the water surface, and integrating the extinction equation over the current effective depth of the reservoir. Second, the amount of algae that settles out of the water column is computed by considering the algae settling rate along with the current effective depth of the reservoir and the simulation time interval.

Basin Name: Current Conditions	
Element Name: Salmon Falls Dam	
Initial Values: Specified Concentrations	
*Initial Organic Nitrogen (MG/L)	5.0
*Initial Ammonia (MG/L)	1.0
*Initial Nitrite (MG/L)	0.2
*Initial Nitrate (MG/L)	0.2
*Initial Organic Phosphorus (MG/L)	0.04
*Initial Inorganic Phosphorus (MG/L)	0.08
*Initial Carbon BOD (MG/L)	41.0
*Initial DO (MG/L)	6.4
*Initial Chlorophyll A (MG/L)	0.007
Air Temp Method:	Constant Value
*Air Temperature (C)	20.0
Water Temp Method:	Constant Value
*Water Temperature (C)	13.0
Windspeed Method:	Constant Value
*Windspeed (KM/HR)	0.0
*Bottom Elevation (M)	0

Figure 425. The Nutrient Simulation Module water quality method for a reservoir element.

## Source

The source element is frequently used to represent a portion of the watershed that will not be explicitly represented in the basin model. The stream flow from the unmodeled portion of the watershed is introduced to the basin model at the point of the source element. The inflow at the source element may be from a stream gaging station or an external simulation model. The hydrograph at the source element is added into the channel network and joins the stream flow computed within the basin model.

When performing water quality calculations, the inflow added to the channel network must also include constituent concentrations. Several methods are available for determining the concentrations to be linked with the inflow hydrograph.

### Selecting a Quality Method

The water quality method for a source is selected on the *Component Editor* for the source element (Figure 426). Access the *Component Editor* by clicking the source element icon on the "Components" tab of the *Watershed Explorer*. You can also access the *Component Editor* by clicking on the element icon in the basin map, if the map is currently open. You can select a water quality method from the list of three available choices. If you choose the `None` method, the source will not compute any water quality results and all constituent concentrations from the element will be zero. Use the selection list to choose the method you wish to use. Each source may use a different method or several sources may use the same method.

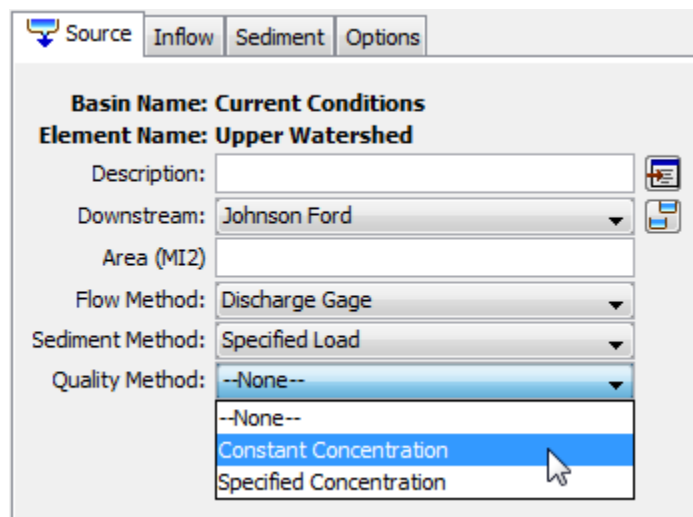

Figure 426. Selecting a water quality method for a source element.

The parameters for each water quality method are presented on a separate *Component Editor* from the source element editor. The "Water Quality" editor is always shown next to the "Sediment" editor. The information shown on the water quality editor will depend on which method is currently selected.

### Constant Concentration

The constant concentration method may be useful for simulations where steady-state conditions prevail most of the time. It may also be useful for preliminary model configuration before moving to a more advanced method. The *Component Editor* is shown in Figure 427.

Source	Sediment	Water Quality	Options
<b>Basin Name: Current Conditions</b>			
<b>Element Name: Upper Watershed</b>			
*Organic Nitrogen (MG/L)	7.8		
*Ammonia (MG/L)	0.04		
*Nitrite (MG/L)	1.09		
*Nitrate (MG/L)	1.14		
*Organic Phosphorus (MG/L)	0.29		
*Inorganic Phosphorus (MG/L)	0.08		
*Dissolved Oxygen (MG/L)	6.64		
*Carbonaceous BOD (MG/L)	3.50		
*Chlorophyll (MG/L)	0.017		

Figure 427. Constant concentration water quality method editor at a source element.

The concentration must be specified for each of the eight parameters. The value is fixed for the time window of the simulation. The values are always specified in milligrams per liter regardless of the unit system of the basin model.

### ***Specified Concentration***

The specified concentration method is designed for situations where the concentration in the inflow from a source is measured at a monitoring station. Alternately, it can be used if the concentration is calculated externally from the program. In either case, the user may enter a time-series of concentration for a particular constituent. The *Component Editor* is shown in Figure 428.

Parameter	Selected Value
Organic Nitrogen:	Org N at 110535
Ammonia:	Ammonia at 110535
Nitrite:	Nitrite at 110535
Nitrate:	Nitrate at 110535
Organic Phosphorus:	Org P at 110535
Inorganic Phosphorus:	Inorg P at 110535
Dissolved Oxygen:	DO at 110535
Carbonaceous BOD:	BOD at 110535
Chlorophyll:	CH-A at 110535

Figure 428. Specified concentration water quality method editor at a source element.

The concentration for each parameter must be specified using a time-series gage. It must be defined in the time-series manager before it can be used in the source element. Select the correct gage from the list of choices for each constituent. The concentration gage type is used for all constituents, so to assist in selecting the correct gage you may wish to use the selector button next to the selection list. The selector includes the description for each available gage to assist in selecting the correct gage.

## Junction

A junction element takes inflow from multiple upstream elements to create a combined outflow. The upstream elements could be two reach elements that join at a confluence. Alternately, the upstream elements could be a reach element and a subbasin element that represent a significant lateral inflow to the stream. The purpose of the junction is to provide conservation of mass when the outflows from multiple elements come together and continue downstream. The conservation of mass is performed assuming there is no storage at the junction. Therefore, all inflow to the junction during a time interval leaves the junction immediately as outflow.

When performing water quality calculations, the junction also performs a mass balance for each constituent. The concentration of each constituent in the inflow is multiplied by the inflow rate to determine the mass of each constituent entering the junction. The mass calculated in this manner for each upstream element is totaled across all constituents. Then the total mass of each constituent is converted

back to a concentration leaving the junction using the outflow rate from the junction.

## **Diversion**

A diversion element begins calculations with a combined inflow hydrograph from upstream elements. Based on the selected diversion method, some portion of the inflow is removed from the main channel and sent to the diversion flow. The remaining flow becomes the outflow from the diversion and continues down the main channel. The conservation of mass that considers the inflow, diversion flow, and outflow, is performed assuming there is no storage at the diversion. Therefore, all inflow to the diversion during a time interval leaves the diversion either as diversion flow or outflow.

When performing water quality calculations, the diversion maintains the concentration of constituents through a mass balance. The concentration of each constituent in the combined inflow is known. The same concentration of each constituent is passed to the diversion flow, assuming the diversion structure is not able to affect the concentration of dissolved constituents. Likewise, the same concentration of each constituent in the inflow is passed to the outflow.

## **Sink**

A sink element takes inflow from multiple upstream elements to create a combined flow that is removed from the channel network. For each time interval, the inflow from each upstream element is accumulated to calculate the total inflow for the interval. The total inflow is presented as the flow rate at the sink.

When performing water quality calculations, the sink performs a mass balance for each constituent. The concentration of each constituent in each upstream inflow is multiplied by the inflow rate to determine the mass of each constituent. The mass calculated in this manner is totaled across all upstream elements for each constituent. Then the total mass of each constituent is converted back to a concentration with respect to the total flow at the sink.

## **Viewing Water Quality Results**

The primary results from water quality calculations are time-series. Available results depend on the type of element, but always include the concentration of each of the eight constituents leaving the element. These results are accessed in the *Watershed Explorer* on the "Results" tab. When water quality calculations are activated, a special folder for water quality results is added under each element icon.

All of the water quality time-series data computed by an individual element are available for viewing. Click on a time-series node to preview the data in the *Component Editor*. You may select multiple time-series data by holding the shift or control key while using the mouse to click on additional nodes. The selected time-series may come from different elements in the same simulation, or the same element in different simulations. Results can also be combined from different types of simulations including simulation runs, optimization trials, depth-area analyses, and forecast alternatives. The selected time-series data will automatically be partitioned into groups by data type if the water quality results are combined with other types of results such as flow or stage.

### ***Subbasin***

The water quality results for a subbasin are the time-series of concentration for each of the constituents. All eight of the constituents are included. The results represent the quality of the water leaving the subbasin and entering the downstream channel network. The organization of the results is very similar to results for the junction element.

### ***Reach***

The water quality results for a reach include the time-series of concentration for each constituent, both entering the reach and leaving the reach. All eight constituents in the nutrient water quality simulation are available at each location of the reach. The organization of the results is shown in Figure 429.



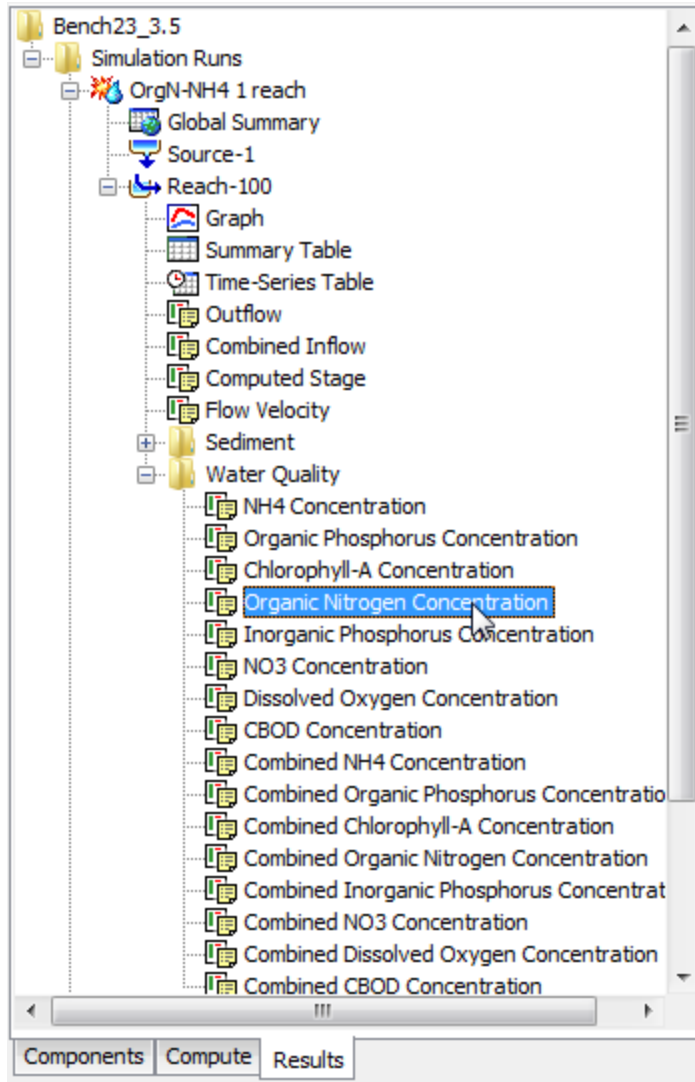

Figure 429. Water quality results for a reach element.

## Reservoir

The water quality results for a reservoir include the time-series of concentration for each constituent, both entering the reservoir and leaving the reservoir. The concentration of each constituent in the reservoir pool is also available. All eight constituents in the nutrient water quality simulation are available at each location of the reservoir. The organization of the results is shown in Figure 430.

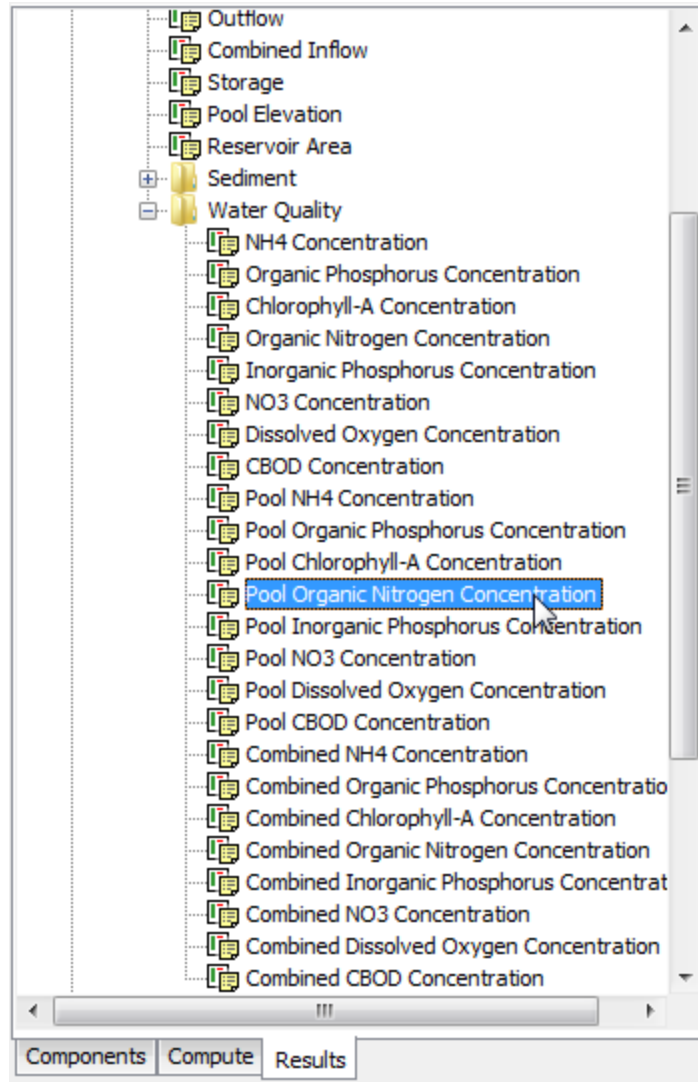

Figure 430. Water quality results for a reservoir element.

### Source

The water quality results for a source are the time-series of concentration for each of the constituents. All eight of the constituents are included. The results represent the quality of the water leaving the source and entering the downstream channel network. The organization of the results is very similar to results for the junction element.

### Junction

The water quality results for a junction are the time-series of concentration for each of the constituents. All eight of the constituents are included, and represent a mass balance of the upstream inflows with the constituent concentrations in each inflow. The results represent the quality of the water leaving the junction and continuing

downstream in the channel network. The organization of the results is shown in Figure 431.

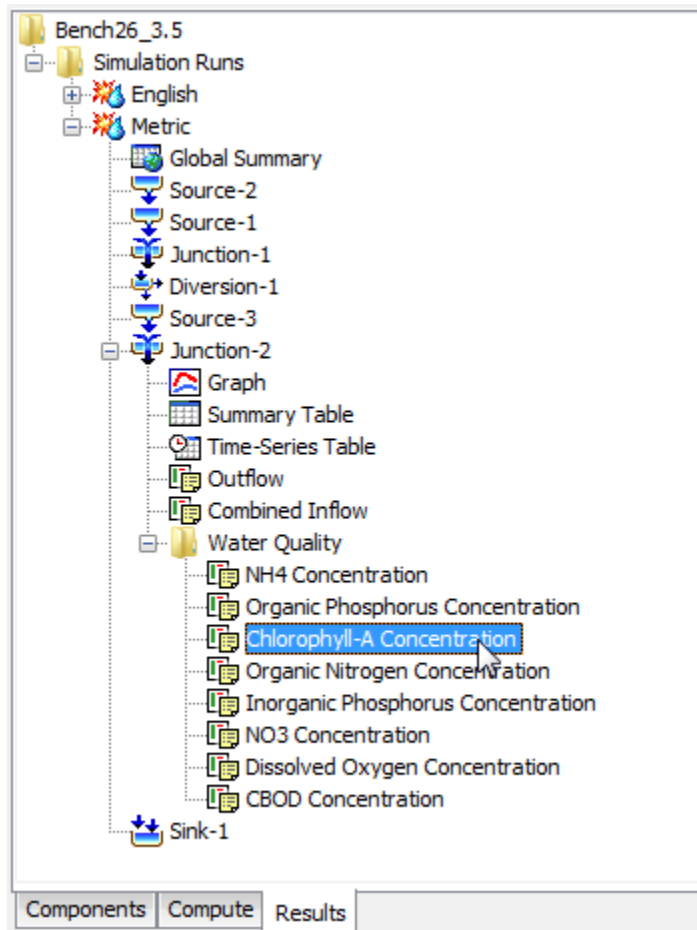

Figure 431. Water quality results for a junction element.

## **Diversion**

The water quality results for a diversion include the time-series of concentration for each constituent entering the diversion. Separate results are also available for the concentration of each constituent in the main outflow that continues downstream in the channel network, and in the diverted flow. All eight constituents in the nutrient water quality simulation are available at each location of the diversion. The organization of the results is very similar to results for the reservoir element.

## **Sink**

The water quality results for a sink are the time-series of concentration for each of the constituents. All eight of the constituents are included, and represent a mass balance of the upstream inflows with the constituent concentrations in each inflow. The results represent the

cumulative quality of the water entering the sink. The organization of the results is very similar to results for the junction element.

## References

Cahyono, M. 1993. *Three-Dimensional Numerical Modelling of Sediment Transport Processes in Non-Stratified Estuarine and Coastal Waters*. Ph.D. Thesis, Dept of Civil Engineering, University of Bradford, Bradford, England.

Fisher, H.B., E.J. List, R.C.Y. Koh, J. Imberger, and N.H. Brooks. 1979. *Mixing in Inland and Coastal Waters*. Academic Press, New York.

Leonard, B. 1971. "A Stable and Accurate Convective Modeling Procedure Based on Quadratic Upstream Interpolation." *Computer Methods in Applied Mechanics and Engineering*, vol 19, pp 59-98.

Leonard, B. 1991. "The ULTIMATE Conservative Difference Scheme Applied to Unsteady One-Dimensional Advection." *Computer Methods in Applied Mechanics and Engineering*, vol 88, pp71-74.

Zhang, Z. and B. Johnson. 2012. *DRiverine Nutrient Simulation Modules Developed for Hydrologic and Hydraulic Models*. U.S. Army Corps of Engineers, Environmental Laboratory, Vicksburg, MS. Technical Report ERDC/EL TR-12-X.

## APPENDIX A

# ***Data Storage in HEC-DSS***

The project DSS file stores time-series and paired data generated in the project. Data is stored in blocks called records that are identified with a unique pathname. Predefined descriptors are used in the C-part of the pathname. This appendix describes the C-part descriptors for each data type.

### ***Descriptors***

AREA Computed area for a reservoir element.

ATI-COLD Computed antecedent temperature index for cold content in the snowmelt method.

ATI-COLDRATE Manually entered antecedent temperature index versus coldrate function for a paired data function.

ATI-MELT Computed antecedent temperature index for meltrate in snowmelt.

ATI-MELTRATE Manually entered antecedent temperature index versus meltrate function for a paired data function.

COLD CONTENT Computed cold content in snowmelt.

CROP COEFFICIENT Manually entered time-series of crop coefficient for a time-series gage.

DISTANCE-ELEVATION Manually entered cross section in the paired data manager.

ELEVATION Computed pool elevation for a reservoir element.

ELEVATION-OBSERVED Observed pool elevation for a reservoir element using the optional observed elevation time-series gage.

ELEVATION-RESIDUAL Residual elevation for a reservoir element with observed elevation. The residual is calculated as computed flow minus the observed elevation.

ELEVATION-AREA A manually entered elevation-area function defined in the paired data manager.

**ELEVATION-FLOW** An elevation-discharge curve defined in the reservoir element. No longer used in the current program version.

**ELEVATION-STORAGE** A manually entered elevation-storage function defined in the paired data manager.

**ET-CANOPY** Computed actual evapotranspiration from the canopy layer in the soil moisture accounting loss method.

**ET-POTENTIAL** Potential evapotranspiration for a subbasin element as computed by the meteorologic model.

**ET-SOIL** Computed actual evapotranspiration from the soil layer in the soil moisture accounting loss method.

**ET-SURFACE** Computed actual evapotranspiration from the surface depression layer in the soil moisture accounting loss method.

**EXCESS-CANOPY** Computed incremental precipitation minus canopy interception in the soil moisture accounting loss method.

**FLOW** Final computed flow for an element.

**FLOW-AUX** Outflow from a reservoir through the auxiliary discharge.

**FLOW-BASE** Computed baseflow for a subbasin element.

**FLOW-COMBINE** Computed total inflow to an element.

**FLOW-DIRECT** Surface flow computed by transforming excess precipitation for a subbasin element.

**FLOW-DIVERSION** Computed diversion flow for a diversion element.

**FLOW-IN** Total inflow to a reach element.

**FLOW-LOCAL** Local flow at a junction when the basin model is set to compute local flow at junctions.

**FLOW-LOCAL-SIM** Computed local flow without blending for a junction when observed flow is present, blending is used, and the basin model is set to compute local flow at junctions.

**FLOW-LOSS** At a reach, the computed channel losses.

**FLOW-OBSERVED** Observed flow for an element using the optional observed flow time-series gage.

**FLOW-RESIDUAL** Residual flow for an element with observed flow. The residual is calculated as computed flow minus the observed flow.

**FLOW-SIM** Computed flow without blending at an element when observed flow is present and blending is used.

**FLOW-UNIT GRAPH** Manually entered unit hydrograph in the paired data manager.

**GROUNDMELT** Manually entered annual groundmelt pattern in the paired data manager.

**INFILTRATION** Computed infiltration from the surface layer to the soil in the soil moisture accounting loss method. Also, the amount of loss attributed to infiltration in the deficit constant loss method.

**LIQUID WATER** Computed liquid water in the snowpack in snowmelt.

**MELTRATE** Manually entered annual meltrate pattern in the paired data manager.

**MOISTURE DEFICIT** Computed moisture deficit in the deficit constant and gridded deficit constant loss methods.

**OUTFLOW-GW** Computed outflow from a groundwater layer to channel baseflow in the soil moisture accounting loss method.

**PERC-SOIL** Computed percolation from the soil layer to the upper groundwater layer in the soil moisture accounting loss method.

**PERC-GW** Computed percolation from the upper groundwater layer to the lower groundwater layer or from the lower groundwater layer out of the system in the soil moisture accounting loss method.

**PERCENT-GRAPH** Manually entered percentage curve in the paired data manager.

**PRECIP-EXCESS** At a subbasin, incremental precipitation minus losses.

**PRECIP-EXCESS-CUM** At a subbasin, cumulative precipitation minus cumulative losses.

**PRECIP-CUM** Cumulative precipitation for a time-series gage.

**PRECIP-INC** Incremental precipitation for a time-series gage or subbasin element.

**PRECIP-LOSS** At a subbasin, the incremental precipitation that was converted to loss during loss calculations.

**PRECIP-LOSS-CUM** At a subbasin, the cumulative precipitation that was converted to loss during loss calculations.

**PRECIP-LWASS** The liquid water available at the soil surface calculated for a subbasin by a snowmelt method.

**PRECIP-LWASS-CUM** The cumulative liquid water available at the soil surface calculated for a subbasin by a snowmelt method.

**PRECIP-STAND DEV** At a subbasin, the standard deviation of incremental precipitation for each time interval computed using gridded precipitation.

**RECOVERED DEFICIT** Computed recovery of the deficit by evapotranspiration in the deficit constant and gridded deficit constant loss methods.

**SATURATION FRACTION** The percentage of the soil layer that is saturated in the deficit and constant or soil moisture accounting loss methods.

**SOLAR RADIATION** Manually entered time-series of solar radiation for a time-series gage.

**STAGE** Computed stage for an element when the optional elevation-discharge curve is used. Also, manually entered time-series of stage for a time-series gage.

**STAGE-CHANNEL** Stage computed in the channel at a diversion element.

**STAGE-FLOW** A manually entered elevation-discharge function defined in the paired data manager.

**STAGE-OBSERVED** Observed stage for an element using the optional observed stage time-series gage.

**STAGE-RESIDUAL** Residual stage for an element with observed stage. The residual is calculated as computed flow minus the observed flow.

**STAGE-SIM** Stage at a reach using the modified Puls or Muskingum Cunge routing methods computed using the simulated flow depth.

**STAGE-TAILWATER** The computed tailwater stage at a reservoir element.

**STAGE-TW-AUX** The computed tailwater stage at the auxiliary discharge from a reservoir element.

**STORAGE** Computed storage for a reservoir element.

**STORAGE-CANOPY** Computed storage depth of the canopy layer in the soil moisture accounting loss method.



**STORAGE-ELEVATION** A storage-elevation curve defined in the reservoir element. No longer used in the current program version.

**STORAGE-FLOW** A manually entered storage-discharge function defined in the paired data manager.

**STORAGE-GW** Computed storage depth of a groundwater layer in the soil moisture accounting loss method.

**STORAGE-SOIL** Computed storage depth of the soil layer in the soil moisture accounting loss method.

**STORAGE-SURFACE** Computed storage depth of the surface layer in the soil moisture accounting loss method.

**SWE** Computed snow water equivalent in snowmelt.

**SWE-OBSERVED** Observed snow water equivalent for a subbasin element using the optional observed SWE time-series gage.

**SWE-RESIDUAL** Residual snow water equivalent for a subbasin element with observed SWE. The residual is calculated as computed flow minus the observed SWE.

**TEMPERATURE** Computed temperature for a subbasin elevation band in snowmelt. Also, manually entered time-series of temperature for a time-series gage.

This Page Left Blank

## APPENDIX B

# Grid Cell File Format

The ModClark transform method requires a grid cell file. The file defines cells for each subbasin. Parameters for each cell are also included in the grid-cell file. This appendix describes the grid-cell file format. The file can be produced using available geographic information system (GIS) tools.

### File Definition

The grid-cell file begins with the keyword "Parameter Order" followed by a colon and parameter keywords indicating the order for reading parameters from the file (Figure 432). The keyword "End" must be on a line by itself after the "Parameter Order" line. Valid parameter keywords are shown in Table 42. Parameter keywords are not case sensitive and are separated by spaces. If the parameter order is not defined, it is assumed to be: Xcoord Ycoord TravelLength Area. The coordinate system of Xcoord and Ycoord used in the file must match the coordinate system used in the gridded DSS records. Typically the coordinate system will be either hydrologic rainfall analysis project (HRAP) or standard hydrologic grid (SHG).

Table 42. Parameter keyword definitions.

Keyword	Definition	Units
XCoord	x-coordinate of the southwest corner of the cell	integer value
YCoord	y-coordinate of the southwest corner of the cell	integer value
TravelLength	travel time index from the cell to the subbasin outlet	kilometers
Area	area of cell within the subbasin	square kilometers

The data for a subbasin begins with the keyword "Subbasin" followed by a colon and the subbasin identifier. One line beginning with the keyword "Grid Cell" follows for each cell in the subbasin. Data for the subbasin ends with the keyword "End". Keywords are not case sensitive and may contain spaces. Blank lines can be included and lines beginning with "#" are ignored as comments. The same grid-cell file can be referenced by more than one subbasin, allowing data for many subbasins to be stored in the same file. The identifier for a subbasin must be exactly the same in the grid-cell file as it is in the basin model.

```
Parameter Order: Xcoord YCoord TravelLength Area
End:
Subbasin: 85
Grid Cell: 633 359 88.38 3.76
Grid Cell: 634 359 84.51 0.18
Grid Cell: 633 358 85.55 16.13
Grid Cell: 632 358 82.55 12.76
Grid Cell: 625 348 13.75 12.07
Grid Cell: 626 348 17.12 0.09
Grid Cell: 622 347 21.19 3.26
Grid Cell: 623 347 15.56 9.96
End:
Subbasin: 86
Grid Cell: 637 361 59.13 6.79
Grid Cell: 638 361 59.04 6.95
Grid Cell: 636 361 56.68 1.17
Grid Cell: 636 360 55.08 16.38
Grid Cell: 636 347 67.96 2.45
Grid Cell: 637 347 71.72 7.41
Grid Cell: 638 347 72.57 8.78
Grid Cell: 639 347 73.32 0.04
End:
```

Figure 432. Sample grid cell file.

This Page Left Blank

## APPENDIX C

# **Map File Format**

Watershed boundaries and stream lines can be displayed as a background for hydrologic elements on the *Basin Model* screen. The use of a background map is optional and not required for any calculations. This appendix describes the background map file format. The file can be produced using available geographic information system (GIS) tools.

### **File Definition**

Watershed boundary and stream line features are both defined in the same file, which is in plain ASCII format. Each feature type is contained in a separate section of the file; it is not important which section is first in the file. Each section begins with the keyword "MapGeo" followed by a colon and either "BoundaryMap" or "RiverMap" (Figure 433).

A map segment defines a list of map coordinates that are connected by a line. A closed segment defines a polygon and an open segment defines a line. Closed segments are used for watershed boundaries and open segments are used for stream lines. Each segment begins with the keyword "MapSegment" followed by a colon and either "Closed" or "Open." The last coordinate in a closed segment is automatically connected to the first coordinate.

Segment coordinates are defined with x-y pairs. Map features are automatically scaled in the *Basin Model* screen. Coordinates are therefore independent of projection, units, and offset. All segments must be in the same coordinate system.

```
MapGeo: BoundaryMap
MapSegment: closed
  582242.875000, 4174922.500000
  582220.875000, 4174961.500000
  582205.625000, 4175013.750000
  581981.000000, 4174672.750000
  582025.812500, 4174696.250000
  582068.812500, 4174711.000000
MapSegment: closed
  582810.125000, 4174024.500000
  582874.687500, 4173973.750000
  582950.687500, 4173902.750000
  582554.000000, 4174000.250000
  582667.687500, 4174003.750000
  582810.125000, 4174024.500000
MapGeo: RiverMap
MapSegment: open
  582750.187500, 4176706.000000
  582687.000000, 4176594.000000
  582657.375000, 4176468.500000
  582613.125000, 4176359.500000
  582482.125000, 4174521.500000
  582555.250000, 4174377.500000
  582555.250000, 4174378.000000
MapSegment: open
  582941.500000, 4175098.500000
  582920.500000, 4175009.750000
  582912.312500, 4174956.500000
  582699.375000, 4174540.500000
  582618.250000, 4174468.250000
```

Figure 433. Sample background map file.



## APPENDIX D

# ***HEC-HMS and HEC-1 Differences***

Development of the Hydrologic Modeling System (HEC-HMS) was initiated as part of the Next Generation Software Project to succeed the aging HEC-1 program for simulating the rainfall-runoff process. However, it was not designed to simply add a graphical user interface to the old program. Instead it was designed to use advances in engineering and computer science wherever possible to improve the quality of simulation results. The modernization process has therefore resulted in some changes in how computations are performed. While these modernizations result in computation differences between the two programs, the HEC-HMS results are preferred because of the modern techniques that have been implemented. Changes in parameter specifications or computations are detailed in the following sections.

### ***Recession Baseflow***

The recession baseflow method includes a recession constant for specifying the rate at which recession flow decreases with time. In HEC-HMS the parameter is defined as the ratio of the current recession flow to the recession flow one day earlier. The HEC-1 parameter, called RTIOR, is defined as the ratio of the current recession flow to the flow one hour later. The following equation can be used to convert an HEC-1 recession constant for use in HEC-HMS:

$$\text{Recession Constant} = \frac{1}{(\text{RTIOR})^{24}}$$

This conversion is automatically applied when importing a HEC-1 file.

### ***Clark Unit Hydrograph***

The Clark method produces a unit hydrograph that theoretically has an infinite number of ordinates, because each ordinate on the tail of the unit hydrograph is computed by multiplying the preceding ordinate by a constant fraction. In both HEC-HMS and HEC-1, the tail of the unit hydrograph is truncated when the volume represented by the unit hydrograph exceeds 99.5% of the unit depth. In HEC-HMS the ordinates are then adjusted using a flow weighting scheme to produce a volume of exactly 100%. No adjustment was made in HEC-1.

## Muskingum Cunge Routing

Hydraulic properties of channels and cross sections are computed differently in HEC-HMS and HEC-1.

### General Channel Properties

In HEC-HMS, properties are computed from the physical properties of the channel, whereas in HEC-1 the properties are computed with formulas based on the kinematic wave assumption. In HEC-HMS the cross-sectional flow area is computed as:

$$A = y(w + zy)$$

and the ratio of wave speed,  $c$ , to flow velocity,  $v$ , is:

$$\frac{c}{v} = \frac{(10wzy) + (16zy^2\sqrt{z^2+1}) + (5w^2) + (6wy\sqrt{z^2+1})}{3(w + 2zy)(w + 2y\sqrt{z^2+1})}$$

where  $w$  is the bottom width,  $z$  is the side slope, and  $y$  is the flow depth. Velocity is computed using Manning's formula and the properties of the cross section.

In HEC-1 the cross-sectional flow area is computed as:

$$A = \left(\frac{Q}{\alpha}\right)^{\frac{1}{m}}$$

and the wave speed,  $c$ , is computed as:

$$c = \alpha mA^{m-1}$$

where  $\alpha$  and  $m$  are kinematic parameters based on the channel shape.

### Eight Point Cross Sections

In HEC-HMS the flow depth for a given discharge is determined from the cross section properties and then area, top width, and wave speed are computed for that depth using the cross section properties. In HEC-1 the discharge, area, top width, and wave speed are computed for 20 depths and stored in a table. During the routing process, area, top width, and wave speed were interpolated from the table for each discharge value. HEC-HMS guarantees that the area, top width, and wave speed are computed exactly for each discharge value.

## ***Kinematic Wave Routing***

Extensive testing of the kinematic wave routing method determined that an error exists in the method as implemented in HEC-1 whereas the calculations are performed correctly in HMS. For each time step, the cross sectional flow area must be calculated at each node in the reach. In HEC-1 this was done incorrectly for the first node, where it used the inflow from the previous time step to compute area instead of the inflow for the current time step. This seemingly small difference in the routing algorithms can lead to differences in the routed peak flow. So far differences of up to 5% have been observed.

## ***Ogee Spillway Flow***

Calculation of the flow coefficient for the spillway is typically broken into several ranges, with different equations used to calculate the coefficient for each range. HEC-1 used two main ranges separated by the criteria of effective head equal to 1.3 times the design head. Below the criteria, the flow coefficient was calculated using results from laboratory experiments. Above the criteria, the coefficient was calculated using a normal depth assumption. The low end of the upper range resulted in calculated spillway flows less than the flow at design head. A linear smoothing was used to transition between the two ranges. HMS uses only a single range, computing the flow coefficient only from experimental results. The HMS results do not have any breaks or transitions in flow as the head on the spillway increases above the design head.

## ***Green and Ampt Infiltration***

Computing infiltration using the Green and Ampt method includes computing the time to ponding. The time to ponding is the length of time required for the precipitation to saturate the soil so that surface runoff begins. In some circumstances, the precipitation rate may decrease after the ponding condition is satisfied. Once this happens, there may not be enough precipitation to maintain the ponding condition. When the precipitation rate increases again the calculations must be adjusted to resatisfy the ponding condition. HEC-1 did not perform this adjustment correctly and would convert all precipitation to excess during any time step when the adjustment was required. HEC-HMS correctly switches between ponded and unponded conditions.

This Page Left Blank

## APPENDIX E

### ***Terms and Conditions of Use***

Use of the program is governed by the terms and conditions of use. They limit what can be done with the program software, waive warranty, limit liability, and indemnify the developers and the United States government. The program cannot be used unless the terms and conditions of use are accepted; the full text is given below.

#### ***Terms and Conditions of Use***

The United States Government, US Army Corps of Engineers, Hydrologic Engineering Center ("HEC") grants to the user the rights to install Hydrologic Modeling System (HEC-HMS) "the Software" (either from a disk copy obtained from HEC, a distributor or another user or by downloading it from a network) and to use, copy and/or distribute copies of the Software to other users, subject to the following Terms and Conditions of Use:

All copies of the Software received or reproduced by or for user pursuant to the authority of this Terms and Conditions of Use will be and remain the property of HEC.

User may reproduce and distribute the Software provided that the recipient agrees to the Terms and Conditions for Use noted herein.

HEC is solely responsible for the content of the Software. The Software may not be modified, abridged, decompiled, disassembled, unobfuscated or reverse engineered. The user is solely responsible for the content, interactions, and effects of any and all amendments, if present, whether they be extension modules, language resource bundles, scripts or any other amendment.

The name "HEC-HMS" must not be used to endorse or promote products derived from the Software. Products derived from the Software may not be called "HEC-HMS" nor may any part of the "HEC-HMS" name appear within the name of derived products.

No part of this Terms and Conditions for Use may be modified, deleted or obliterated from the Software.

No part of the Software may be exported or re-exported in contravention of U.S. export laws or regulations.

Waiver of Warranty

THE UNITED STATES GOVERNMENT AND ITS AGENCIES, OFFICIALS, REPRESENTATIVES, AND EMPLOYEES, INCLUDING ITS CONTRACTORS AND SUPPLIERS PROVIDE HEC-HMS "AS IS," WITHOUT ANY WARRANTY OR CONDITION, EXPRESS, IMPLIED OR STATUTORY, AND SPECIFICALLY DISCLAIM ANY IMPLIED WARRANTIES OF TITLE, MERCHANTABILITY, FITNESS FOR A PARTICULAR PURPOSE AND NON-INFRINGEMENT. Depending on state law, the foregoing disclaimer may not apply to you, and you may also have other legal rights that vary from state to state.

#### Limitation of Liability

IN NO EVENT SHALL THE UNITED STATES GOVERNMENT AND ITS AGENCIES, OFFICIALS, REPRESENTATIVES, AND EMPLOYEES, INCLUDING ITS CONTRACTORS AND SUPPLIERS, BE LIABLE FOR LOST PROFITS OR ANY SPECIAL, INCIDENTAL OR CONSEQUENTIAL DAMAGES ARISING OUT OF OR IN CONNECTION WITH USE OF HEC-HMS REGARDLESS OF CAUSE, INCLUDING NEGLIGENCE.

THE UNITED STATES GOVERNMENT'S LIABILITY, AND THE LIABILITY OF ITS AGENCIES, OFFICIALS, REPRESENTATIVES, AND EMPLOYEES, INCLUDING ITS CONTRACTORS AND SUPPLIERS, TO YOU OR ANY THIRD PARTIES IN ANY CIRCUMSTANCE IS LIMITED TO THE REPLACEMENT OF CERTIFIED COPIES OF HEC-HMS WITH IDENTIFIED ERRORS CORRECTED. Depending on state law, the above limitation or exclusion may not apply to you.

#### Indemnity

As a voluntary user of HEC-HMS you agree to indemnify and hold the United States Government, and its agencies, officials, representatives, and employees, including its contractors and suppliers, harmless from any claim or demand, including reasonable attorneys' fees, made by any third party due to or arising out of your use of HEC-HMS or breach of this Agreement or your violation of any law or the rights of a third party.

#### Assent

By using this program you voluntarily accept these terms and conditions. If you do not agree to these terms and conditions, uninstall the program and return any program materials to HEC (If you downloaded the program and do not have disk media, please delete all copies, and cease using the program.)